



The Question Bank of **Mechanics**

for CAIE 9709 paper 4.

v1.0

Edited by Thoridal

Instructions for Use

- This question bank is organized by chapter for systematic revision.
- This question bank is compiled based on the 26-27 CAIE Mechanics syllabus, which is included as appendix.
- Each question includes its source for reference.
- Mark schemes are provided in the separate answer booklet.
- The formula sheet (MF19) is included as appendix.
- Use this resource for targeted practice and exam preparation.

Contents

1	Linear motion graphs (s-t and v-t)	5
2	Variable acceleration in one dimension	47
3	Uniformly accelerated motion	127
4	Resolving forces in two dimensions	189
5	Friction	265
6	Connected particles	325
7	Energy, work and power	401
8	Momentum and collision	541
	Formula Sheet MF19	587
	Syllabus 26-27 Mechanics	605

Chapter 1

Linear motion graphs (s-t and v-t)

1. [9709/s25/41/q3]

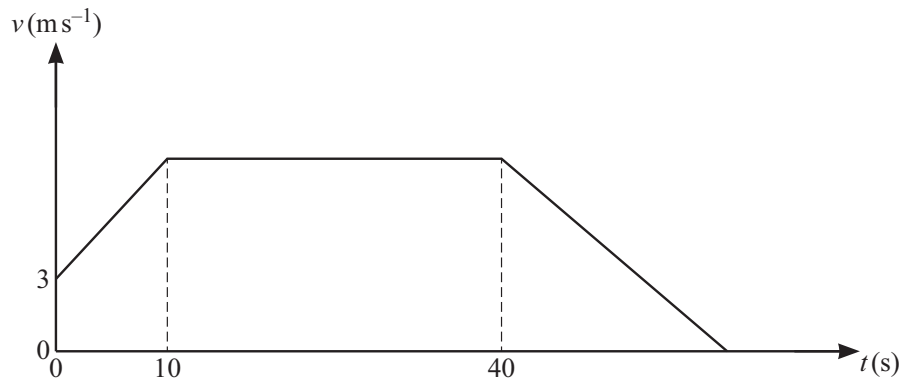

The diagram shows the velocity-time graph of the motion of a cyclist. The graph consists of three straight line segments. The cyclist passes a point O with speed 3 m s^{-1} and then accelerates for 10 s with constant acceleration 0.5 m s^{-2} . He then travels at constant speed for 30 s before decelerating, coming to rest at point P , covering a distance of 80 m whilst decelerating.

- (a) Find the total time taken for the journey from O to P . [3]
- (b) On the given axes, sketch a displacement-time graph for the cyclist's journey from O to P , showing on your graph the distances travelled after 10 s and 40 s . [4]

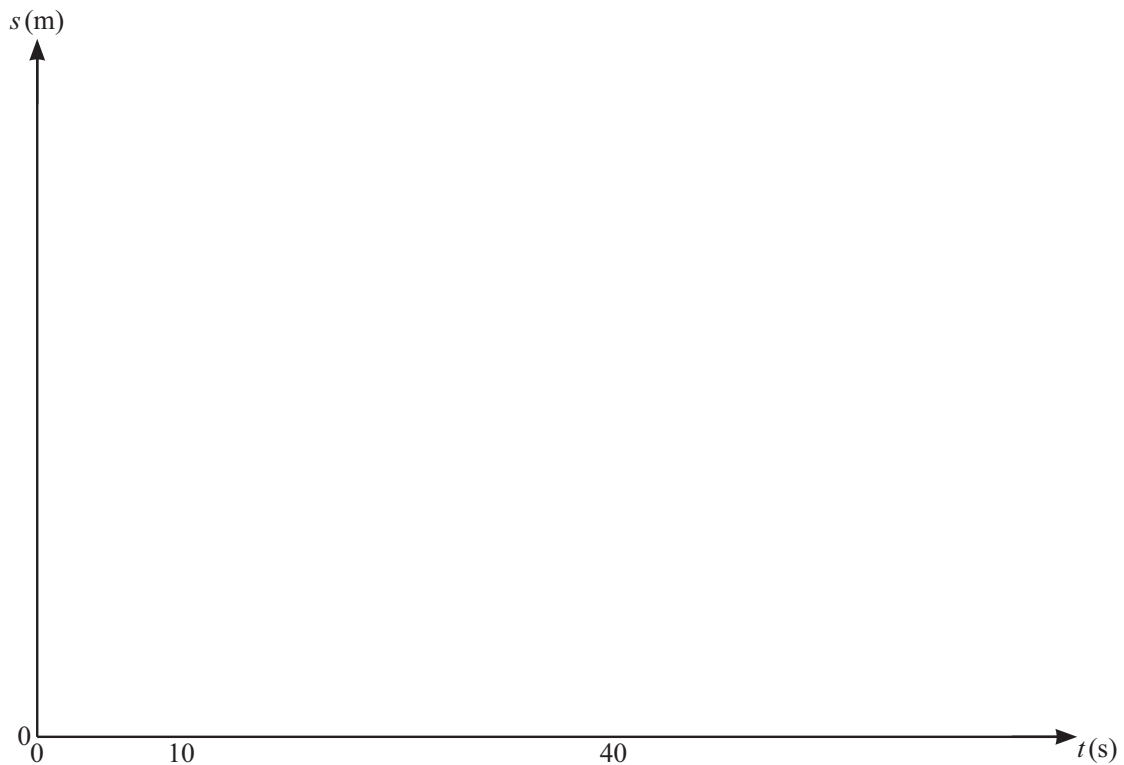

2. [9709/s25/42/q4]

A car is travelling along a straight horizontal road. The car passes through a point A , on the road travelling at a speed of 15 ms^{-1} , and then accelerates uniformly at 0.4 ms^{-2} for 30 seconds. The car then moves at constant speed for $3T$ seconds, where $T < 30$. The car then decelerates uniformly at 0.2 ms^{-2} and after a further T seconds passes through a point B on the road.

- (a) On the given axes, sketch a velocity-time graph for the motion of the car between points A and B . [2]



The distance from A to B is 2750 m.

- (b) Find the value of T . [6]

The car continues its journey from B , decelerating uniformly at 0.5 ms^{-2} until it comes to rest at a point C on the road.

- (c) Find the total distance from A to C . [3]

3. [9709/s25/43/q3]

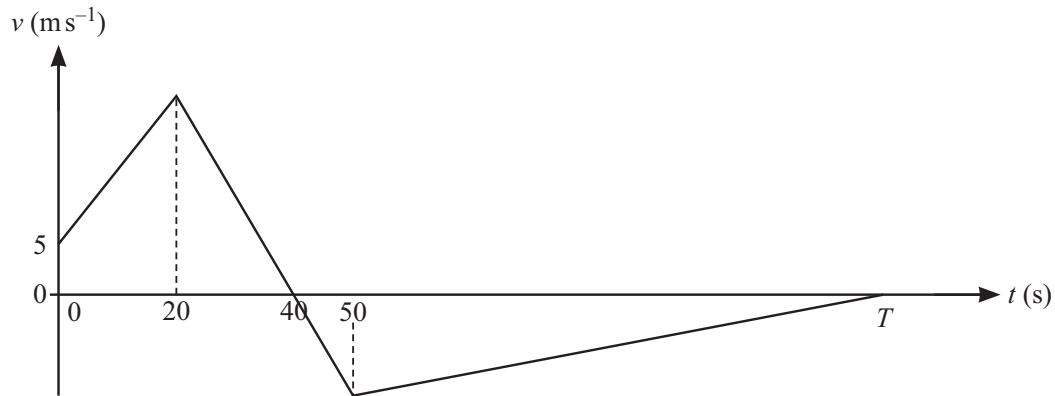

The diagram shows a velocity-time graph which models the motion of a particle. The graph consists of 3 straight line segments. The velocity of the particle at time t s after passing a fixed point O is $v \text{ ms}^{-1}$. The particle leaves O with a velocity of 5 ms^{-1} and accelerates at 0.75 ms^{-2} for 20 s. The particle then decelerates for the next 30 s. At $t = 40$, the velocity of the particle is zero. After $t = 40$, the particle starts to travel back to O , coming to rest at O at time T s.

- (a) Find the value of T . [5]
- (b) Find the acceleration of the particle from $t = 50$ to $t = T$. [2]

4. [9709/w25/42/q1]

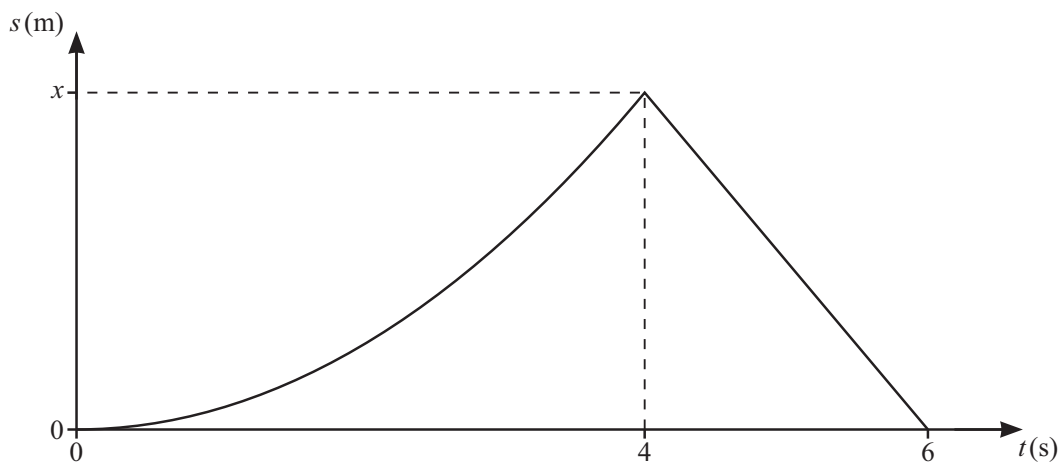

The diagram shows the displacement-time graph for the motion of a particle. The particle starts from rest at a point O and travels with constant acceleration $a \text{ m s}^{-2}$, taking 4 s to move a distance of x m. The particle then returns to O with constant speed of 40 m s^{-1} , over a period of 2 s.

Find the value of x and the value of a .

[3]

5. [9709/w25/43/q1]

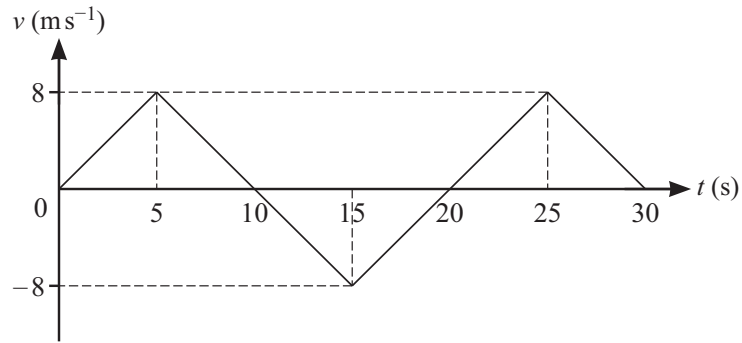

The diagram shows the velocity-time graph for the motion of an athlete. The athlete runs in a straight line from point A to point B , runs back to point A and finishes at point B . The graph consists of four straight line segments.

(a) Find the deceleration of the athlete 7 seconds after leaving A . [1]

(b) Find the total distance travelled by the athlete. [2]

6. [9709/w25/45/q2]

An athlete runs along a straight horizontal road. The athlete starts from rest and accelerates at 0.5 m s^{-2} reaching a speed of $V \text{ m s}^{-1}$. The athlete maintains this speed of $V \text{ m s}^{-1}$ for T s before decelerating at 0.2 m s^{-2} back to rest. The athlete covers a total distance of 1350m in 246 seconds.

- (a) Sketch the velocity-time graph for the motion of the athlete. [1]



2

- (b) Find T in terms of V , and hence show that $7V - 492V + 2700 = 0$. [4]

- (c) Find the value of V , giving a justification for your answer. [2]

7. [9709/m24/42/q1]

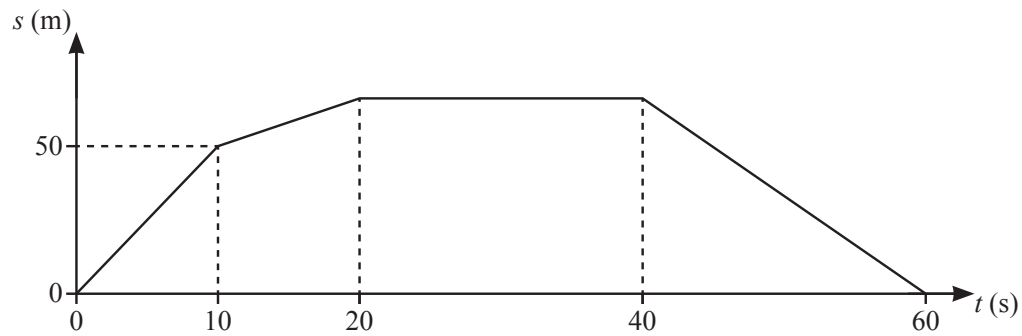

The displacement of a particle at time t s after leaving a fixed point O is s m. The diagram shows a displacement-time graph which models the motion of the particle. The graph consists of 4 straight line segments. The particle travels 50 m in the first 10 s, then travels at 2 m s^{-1} for a period of 10 s. The particle then comes to rest for a period of 20 s, before returning to its starting point when $t = 60$.

- (a) Find the velocity of the particle during the last 20 s of its motion. [2]
- (b) Sketch a velocity-time graph for the motion of the particle from $t = 0$ to $t = 60$. [3]

8. [9709/w24/41/q4]

A bus travels between two stops, A and B . The bus starts from rest at A and accelerates at a constant rate of $a \text{ m s}^{-2}$ until it reaches a speed of 16 m s^{-1} . It then travels at this constant speed before decelerating at a constant rate of $0.75a \text{ m s}^{-2}$, coming to rest at B . The total time for the journey is 240 s.

- (a) Sketch the velocity-time graph for the bus's journey from A to B . [1]



- (b) Find an expression, in terms of a , for the length of time that the bus is travelling with constant speed. [2]
- (c) Given that the distance from A to B is 3000 m, find the value of a . [3]

9. [9709/w24/42/q1]

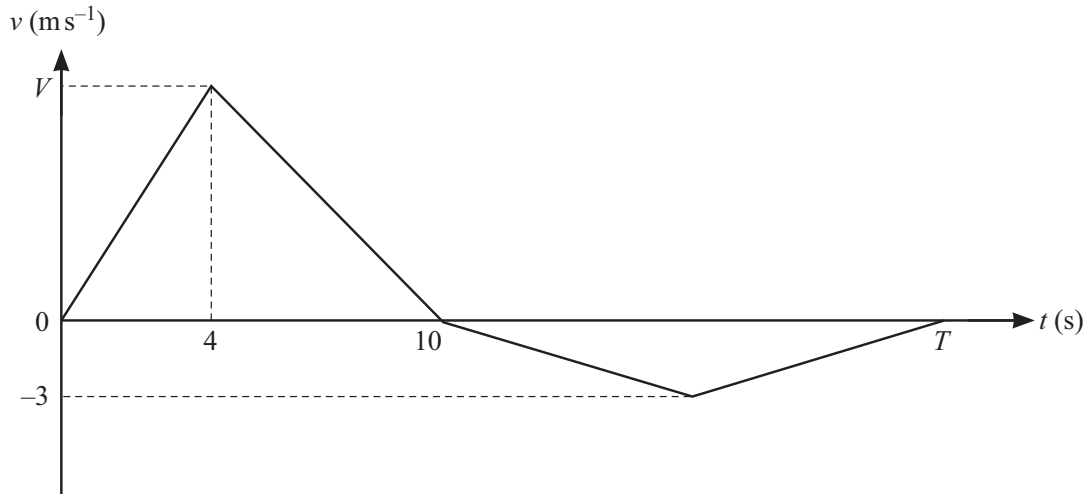

The velocity of a particle moving in a straight line at time t seconds after leaving a fixed point O is $v \text{ ms}^{-1}$. The diagram shows a velocity-time graph which models the motion of the particle from $t = 0$ to $t = T$. The graph consists of four straight line segments. The particle accelerates from rest to a speed of $V \text{ ms}^{-1}$ over a period of 4 s, and then decelerates at $\frac{5}{3} \text{ m s}^{-2}$ to instantaneous rest over a period of 6 s. The particle then travels back towards O , reaching a maximum speed of 3 m s^{-1} before coming to rest at time $t = T$.

- (a) Find the value of V . [2]
- (b) Given that the total distance travelled by the particle from $t = 0$ to $t = T$ is 68 m, find the value of T . [3]

10. [9709/w24/43/q6]

A particle moves in a straight line. It starts from rest, at time $t = 0$, and accelerates at $0.6t \text{ m s}^{-2}$ for 4 s, reaching a speed of $V \text{ m s}^{-1}$. The particle then travels at $V \text{ m s}^{-1}$ for 11 s, and finally slows down, with constant deceleration, stopping after a further 5 s.

- (a) Show that $V = 4.8$. [1]
- (b) Sketch a velocity-time graph for the motion. [3]
- (c) Find an expression, in terms of t , for the velocity of the particle for $15 \leq t \leq 20$. [2]
- (d) Find the total distance travelled by the particle. [4]

11. [9709/s23/41/q4]

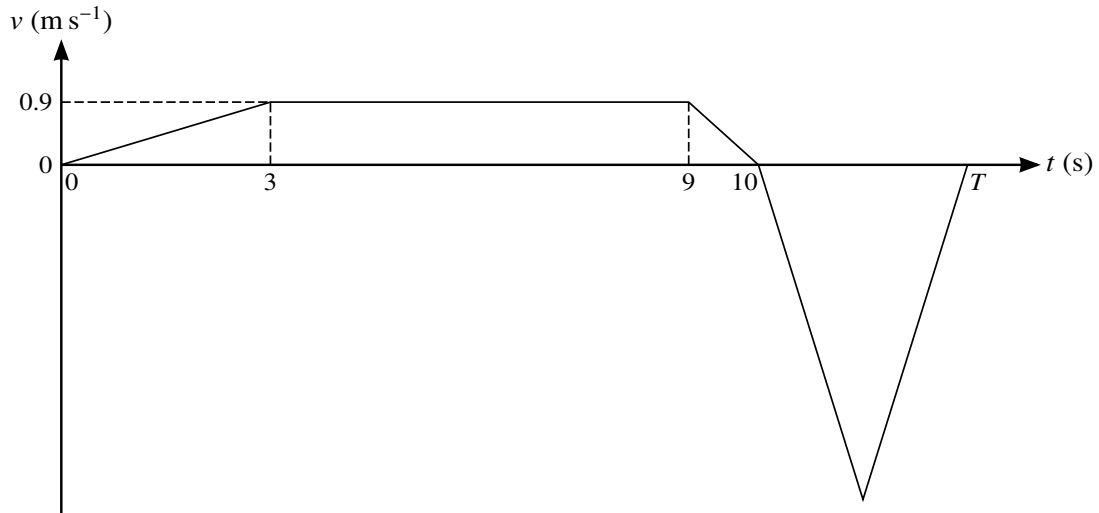

The velocity of a particle at time t s after leaving a fixed point O is $v \text{ m s}^{-1}$. The diagram shows a velocity-time graph which models the motion of the particle. The graph consists of 5 straight line segments. The particle accelerates to a speed of 0.9 m s^{-1} in a period of 3 s, then travels at constant speed for 6 s, and then comes instantaneously to rest 1 s later. The particle then moves back and returns to rest at O at time T s.

- (a) Find the distance travelled by the particle in the first 10 s of its motion. [2]
- (b) Given that $T = 12$, find the minimum velocity of the particle. [2]
- (c) Given instead that the greatest speed of the particle is 3 m s^{-1} , find the value of T and hence find the average speed of the particle for the whole of the motion. [4]

12. [9709/s23/43/q6]

An elevator is pulled vertically upwards by a cable. The elevator accelerates at 0.4 m s^{-2} for 5 s, then travels at constant speed for 25 s. The elevator then decelerates at 0.2 m s^{-2} until it comes to rest.

- (a) Find the greatest speed of the elevator and hence draw a velocity-time graph for the motion of the elevator. [3]
- (b) Find the total distance travelled by the elevator. [2]

The mass of the elevator is 1200 kg and there is a crate of mass m kg resting on the floor of the elevator.

- (c) Given that the tension in the cable when the elevator is decelerating is 12 250 N, find the value of m . [3]
- (d) Find the greatest magnitude of the force exerted on the crate by the floor of the elevator, and state its direction. [3]

13. [9709/w23/41/q3]

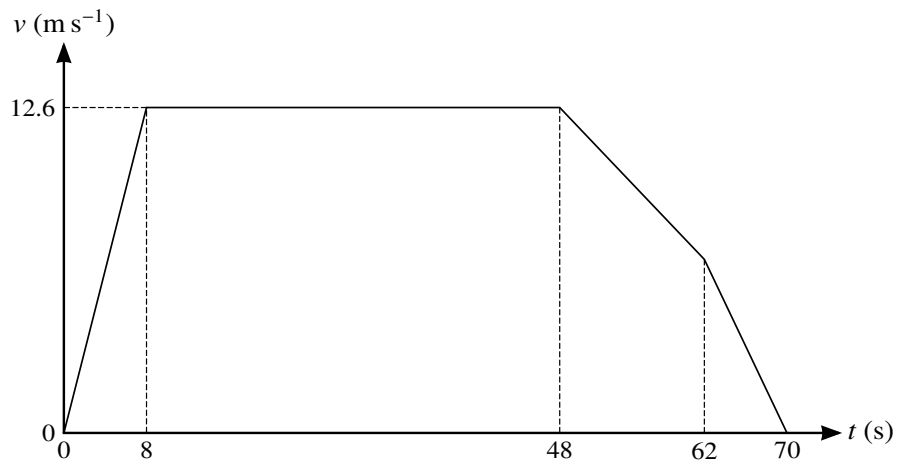

The diagram shows the velocity-time graph for the motion of a bus. The bus starts from rest and accelerates uniformly for 8 seconds until it reaches a speed of 12.6 m s^{-1} . The bus maintains this speed for 40 seconds. It then decelerates uniformly in two stages. Between 48 and 62 seconds the bus decelerates at $a \text{ m s}^{-2}$ and between 62 and 70 seconds it decelerates at $2a \text{ m s}^{-2}$ until coming to rest.

- (a) Find the distance covered by the bus in the first 8 seconds. [1]
(b) Find the value of a . [3]
(c) Find the average speed of the bus for the whole journey. [4]

14. [9709/s22/41/q1]

A car starts from rest and moves in a straight line with constant acceleration for a distance of 200 m, reaching a speed of 25 m s^{-1} . The car then travels at this speed for 400 m, before decelerating uniformly to rest over a period of 5 s.

- (a) Find the time for which the car is accelerating. [2]
- (b) Sketch the velocity–time graph for the motion of the car, showing the key points. [2]
- (c) Find the average speed of the car during its motion. [2]

15. [9709/s22/42/q4]

A particle A , moving along a straight horizontal track with constant speed 8 m s^{-1} , passes a fixed point O . Four seconds later, another particle B passes O , moving along a parallel track in the same direction as A . Particle B has speed 20 m s^{-1} when it passes O and has a constant deceleration of 2 m s^{-2} . B comes to rest when it returns to O .

- (a) Find expressions, in terms of t , for the displacement from O of each particle t seconds after B passes O . [3]
- (b) Find the values of t when the particles are the same distance from O . [3]
- (c) On the given axes, sketch the displacement-time graphs for both particles, for values of t from 0 to 20. [3]

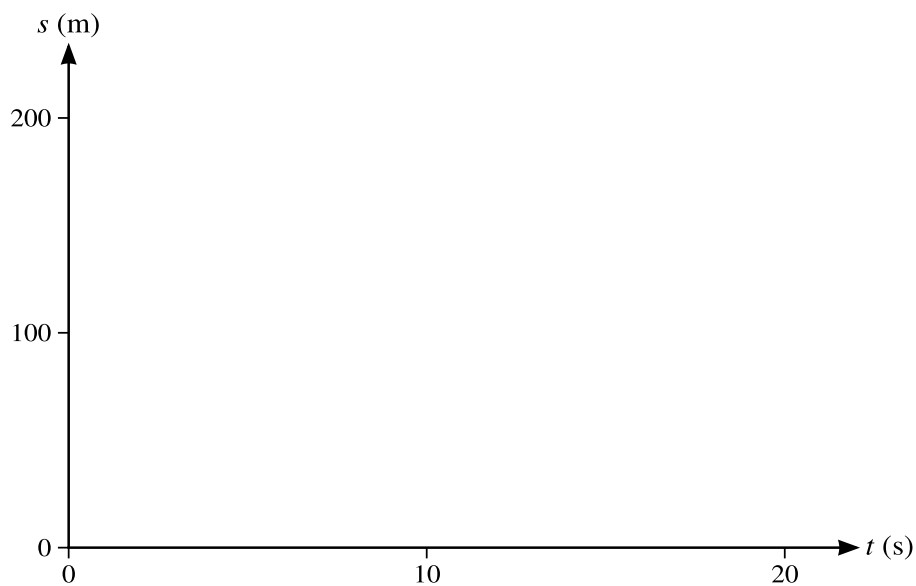

16. [9709/s22/43/q3]

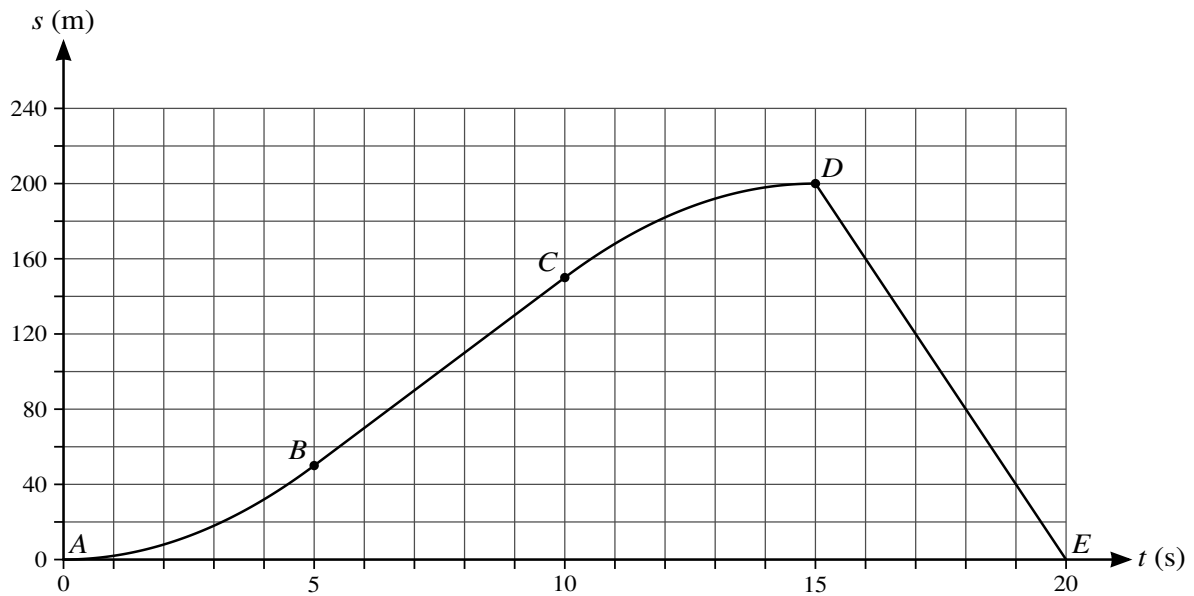

The displacement of a particle moving in a straight line is s metres at time t seconds after leaving a fixed point O . The particle starts from rest and passes through points P , Q and R , at times $t = 5$, $t = 10$ and $t = 15$ respectively, and returns to O at time $t = 20$. The distances OP , OQ and OR are 50 m, 150 m and 200 m respectively.

The diagram shows a displacement-time graph which models the motion of the particle from $t = 0$ to $t = 20$. The graph consists of two curved segments AB and CD and two straight line segments BC and DE .

- (a) Find the speed of the particle between $t = 5$ and $t = 10$. [1]
- (b) Find the acceleration of the particle between $t = 0$ and $t = 5$, given that it is constant. [2]
- (c) Find the average speed of the particle during its motion. [2]

17. [9709/w22/41/q5]

A particle P moves on the x -axis from the origin O with an initial velocity of -20 m s^{-1} . The acceleration $a \text{ m s}^{-2}$ at time $t \text{ s}$ after leaving O is given by $a = 12 - 2t$.

- (a) Sketch a velocity-time graph for $0 \leq t \leq 12$, indicating the times when P is at rest. [5]
- (b) Find the total distance travelled by P in the interval $0 \leq t \leq 12$. [5]

18. [9709/m21/42/q4]

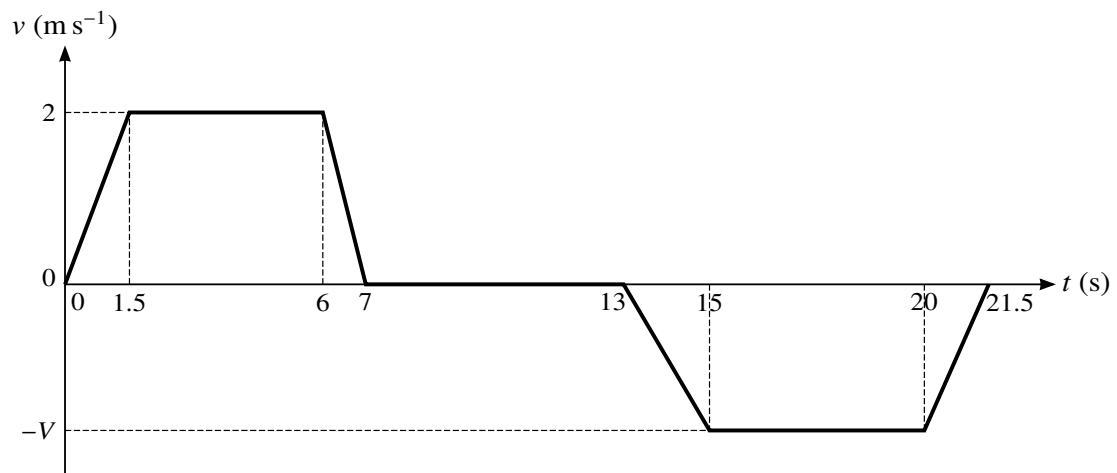

An elevator moves vertically, supported by a cable. The diagram shows a velocity-time graph which models the motion of the elevator. The graph consists of 7 straight line segments.

The elevator accelerates upwards from rest to a speed of 2 m s^{-1} over a period of 1.5 s and then travels at this speed for 4.5 s, before decelerating to rest over a period of 1 s.

The elevator then remains at rest for 6 s, before accelerating to a speed of $V \text{ m s}^{-1}$ downwards over a period of 2 s. The elevator travels at this speed for a period of 5 s, before decelerating to rest over a period of 1.5 s.

- (a) Find the acceleration of the elevator during the first 1.5 s. [1]
- (b) Given that the elevator starts and finishes its journey on the ground floor, find V . [2]
- (c) The combined weight of the elevator and passengers on its upward journey is 1500 kg. Assuming that there is no resistance to motion, find the tension in the elevator cable on its upward journey when the elevator is decelerating. [3]

19. [9709/s21/42/q7]

A particle P moving in a straight line starts from rest at a point O and comes to rest 16 s later. At time t s after leaving O , the acceleration $a \text{ m s}^{-2}$ of P is given by

$$a = 6 + 4t \quad 0 \leq t < 2,$$

$$a = 14 \quad 2 \leq t < 4,$$

$$a = 16 - 2t \quad 4 \leq t \leq 16.$$

There is no sudden change in velocity at any instant.

(a) Find the values of t when the velocity of P is 55 m s^{-1} . [5]

(b) Complete the sketch of the velocity-time diagram. [2]

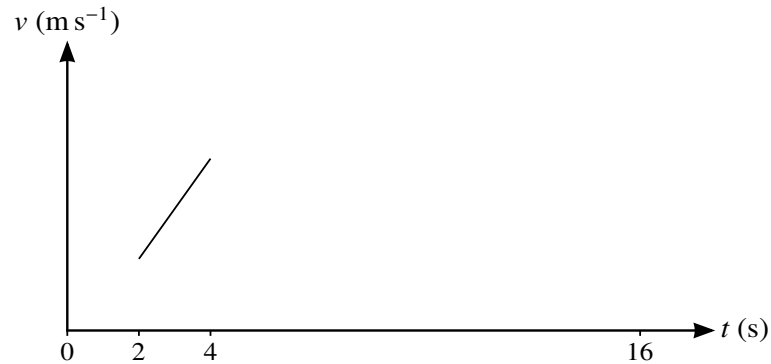

(c) Find the distance travelled by P when it is decelerating. [3]

20. [9709/w21/42/q1]

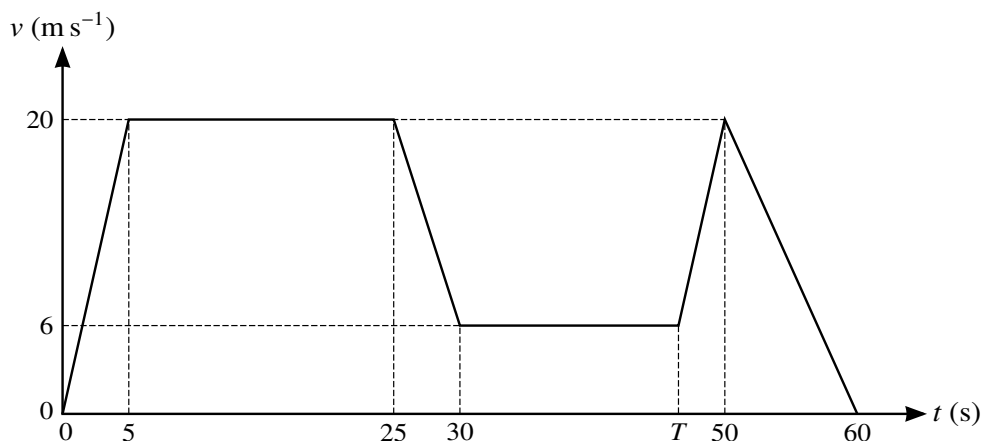

The diagram shows a velocity-time graph which models the motion of a car. The graph consists of six straight line segments. The car accelerates from rest to a speed of 20 m s^{-1} over a period of 5 s, and then travels at this speed for a further 20 s. The car then decelerates to a speed of 6 m s^{-1} over a period of 5 s. This speed is maintained for a further $(T - 30)$ s. The car then accelerates again to a speed of 20 m s^{-1} over a period of $(50 - T)$ s, before decelerating to rest over a period of 10 s.

- (a) Given that during the two stages of the motion when the car is accelerating, the accelerations are equal, find the value of T . [2]
- (b) Find the total distance travelled by the car during the motion. [2]

21. [9709/s20/42/q1]

A tram starts from rest and moves with uniform acceleration for 20 s. The tram then travels at a constant speed, $V \text{ m s}^{-1}$, for 170 s before being brought to rest with a uniform deceleration of magnitude twice that of the acceleration. The total distance travelled by the tram is 2.775 km.

- (a) Sketch a velocity-time graph for the motion, stating the total time for which the tram is moving. [2]
- (b) Find V . [2]
- (c) Find the magnitude of the acceleration. [2]

22. [9709/s20/42/q6]

A particle P moves in a straight line. The velocity $v \text{ m s}^{-1}$ at time $t \text{ s}$ is given by

$$\begin{aligned}v &= 2t + 1 && \text{for } 0 \leq t \leq 5, \\v &= 36 - t^2 && \text{for } 5 \leq t \leq 7, \\v &= 2t - 27 && \text{for } 7 \leq t \leq 13.5.\end{aligned}$$

- (a) Sketch the velocity-time graph for $0 \leq t \leq 13.5$. [3]
- (b) Find the acceleration at the instant when $t = 6$. [2]
- (c) Find the total distance travelled by P in the interval $0 \leq t \leq 13.5$. [5]

23. [9709/s20/43/q4]

A car starts from rest and moves in a straight line with constant acceleration $a \text{ m s}^{-2}$ for a distance of 50 m. The car then travels with constant velocity for 500 m for a period of 25 s, before decelerating to rest. The magnitude of this deceleration is $2a \text{ m s}^{-2}$.

(a) Sketch the velocity-time graph for the motion of the car. [1]



(b) Find the value of a . [3]

(c) Find the total time for which the car is in motion. [3]

24. [9709/w20/42/q4]

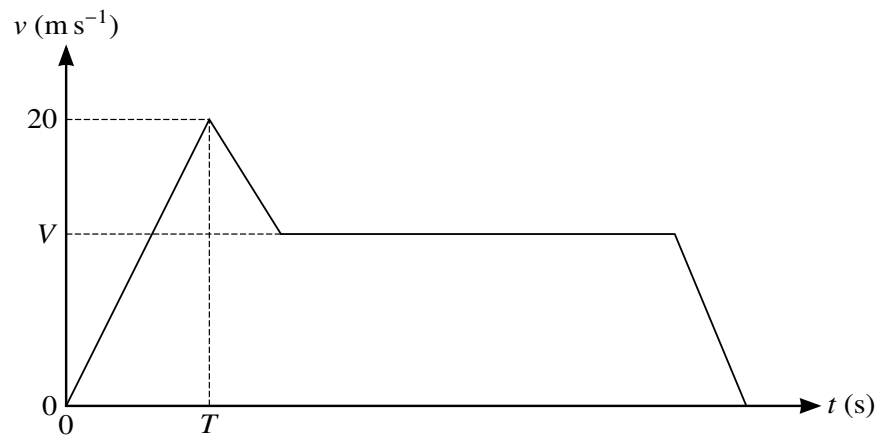

The diagram shows a velocity-time graph which models the motion of a car. The graph consists of four straight line segments. The car accelerates at a constant rate of 2 m s^{-2} from rest to a speed of 20 m s^{-1} over a period of T s. It then decelerates at a constant rate for 5 seconds before travelling at a constant speed of $V \text{ m s}^{-1}$ for 27.5 s. The car then decelerates to rest at a constant rate over a period of 5 s.

- (a) Find T . [1]
- (b) Given that the distance travelled up to the point at which the car begins to move with constant speed is one third of the total distance travelled, find V . [4]

25. [9709/m19/42/q5]

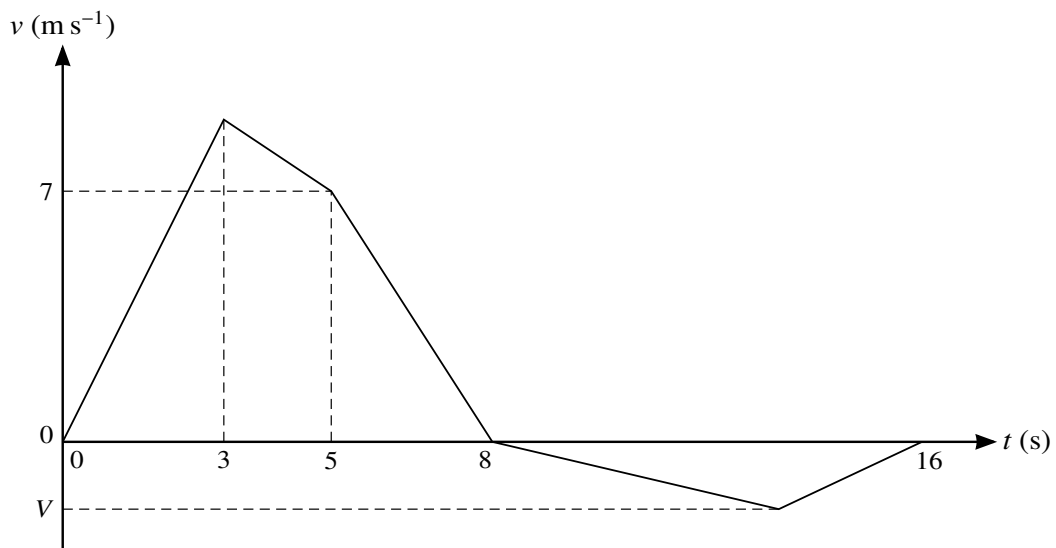

The velocity of a particle moving in a straight line is $v \text{ m s}^{-1}$ at time t seconds after leaving a fixed point O . The diagram shows a velocity-time graph which models the motion of the particle from $t = 0$ to $t = 16$. The graph consists of five straight line segments. The acceleration of the particle from $t = 0$ to $t = 3$ is 3 m s^{-2} . The velocity of the particle at $t = 5$ is 7 m s^{-1} and it comes to instantaneous rest at $t = 8$. The particle then comes to rest again at $t = 16$. The minimum velocity of the particle is $V \text{ m s}^{-1}$.

- (i) Find the distance travelled by the particle in the first 8 s of its motion. [3]
- (ii) Given that when the particle comes to rest at $t = 16$ its displacement from O is 32 m, find the value of V . [4]

26. [9709/s19/43/q1]

A bus moves in a straight line between two bus stops. The bus starts from rest and accelerates at 2.1 m s^{-2} for 5 s. The bus then travels for 24 s at constant speed and finally slows down, with a constant deceleration, stopping in a further 6 s. Sketch a velocity-time graph for the motion and hence find the distance between the two bus stops. [5]

27. [9709/w19/41/q6.3]

A particle of mass 0.4 kg is released from rest at a height of 1.8 m above the surface of the water in a tank. There is no instantaneous change of speed when the particle enters the water. The water exerts an upward force of 5.6 N on the particle when it is in the water.

- (i) Find the velocity of the particle at the instant when it reaches the surface of the water. [2]
- (ii) Find the time that it takes from the instant when the particle enters the water until it comes to instantaneous rest in the water. You may assume that the tank is deep enough so that the particle does not reach the bottom of the tank. [4]
- (iii) Sketch a velocity-time graph for the motion of the particle from the instant at which it is released until it comes to instantaneous rest in the water. [3]

28. [9709/w19/42/q2]

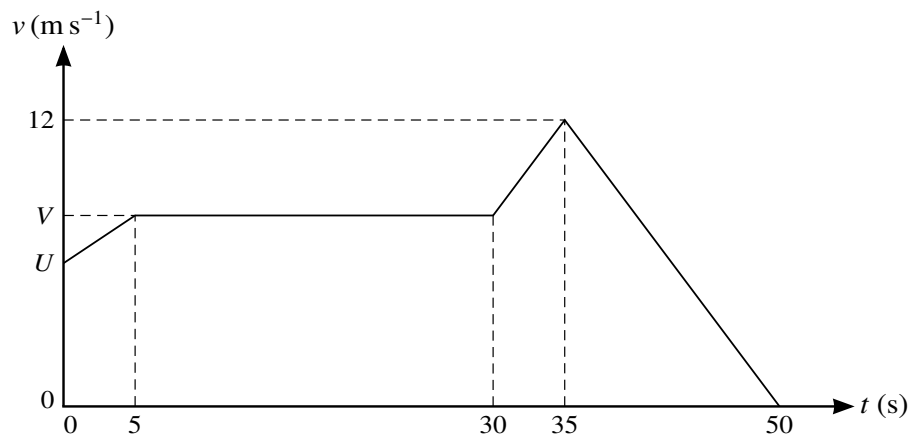

The diagram shows a velocity-time graph which models the motion of a tractor. The graph consists of four straight line segments. The tractor passes a point O at time $t = 0$ with speed $U \text{ m s}^{-1}$. The tractor accelerates to a speed of $V \text{ m s}^{-1}$ over a period of 5 s, and then travels at this speed for a further 25 s. The tractor then accelerates to a speed of 12 m s^{-1} over a period of 5 s. The tractor then decelerates to rest over a period of 15 s.

- (i) Given that the acceleration of the tractor between $t = 30$ and $t = 35$ is 0.8 m s^{-2} , find the value of V . [2]
- (ii) Given also that the total distance covered by the tractor in the 50 seconds of motion is 375 m, find the value of U . [3]

29. [9709/w19/43/q7.3]

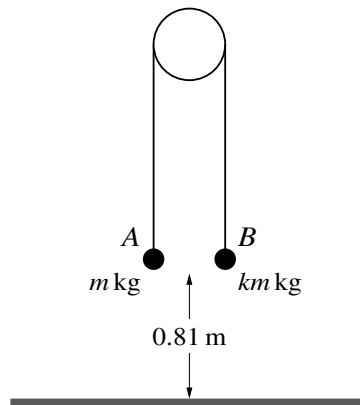

Two particles A and B have masses m kg and km kg respectively, where $k > 1$. The particles are attached to the ends of a light inextensible string. The string passes over a fixed smooth pulley and the particles hang vertically below it. Both particles are at a height of 0.81 m above horizontal ground (see diagram). The system is released from rest and particle B reaches the ground 0.9 s later. The particle A does not reach the pulley in its subsequent motion.

- (i) Find the value of k and show that the tension in the string before B reaches the ground is equal to $12m$ N. [7]

At the instant when B reaches the ground, the string breaks.

- (ii) Show that the speed of A when it reaches the ground is 5.97 m s⁻¹, correct to 3 significant figures, and find the time taken, after the string breaks, for A to reach the ground. [4]
- (iii) Sketch a velocity-time graph for the motion of particle A from the instant when the system is released until A reaches the ground. [2]

30. [9709/m18/42/q7.3]

A particle P moves in a straight line. The velocity $v \text{ m s}^{-1}$ at time $t \text{ s}$ is given by

$$v = 4 + 0.2t \quad \text{for } 0 \leq t \leq 10,$$
$$v = -2 + \frac{800}{t^2} \quad \text{for } 10 \leq t \leq 20.$$

- (i) Find the acceleration of P during the first 10 s. [1]
- (ii) Find the acceleration of P when $t = 20$. [2]
- (iii) Sketch the velocity-time graph for $0 \leq t \leq 20$. [3]
- (iv) Find the total distance travelled by P in the interval $0 \leq t \leq 20$. [5]

31. [9709/s18/41/q5]

A sprinter runs a race of 200 m. His total time for running the race is 20 s. He starts from rest and accelerates uniformly for 6 s, reaching a speed of 12 m s^{-1} . He maintains this speed for the next 10 s, before decelerating uniformly to cross the finishing line with speed $V \text{ m s}^{-1}$.

- (i) Find the distance travelled by the sprinter in the first 16 s of the race. Hence sketch a displacement-time graph for the 20 s of the sprinter's race. [6]

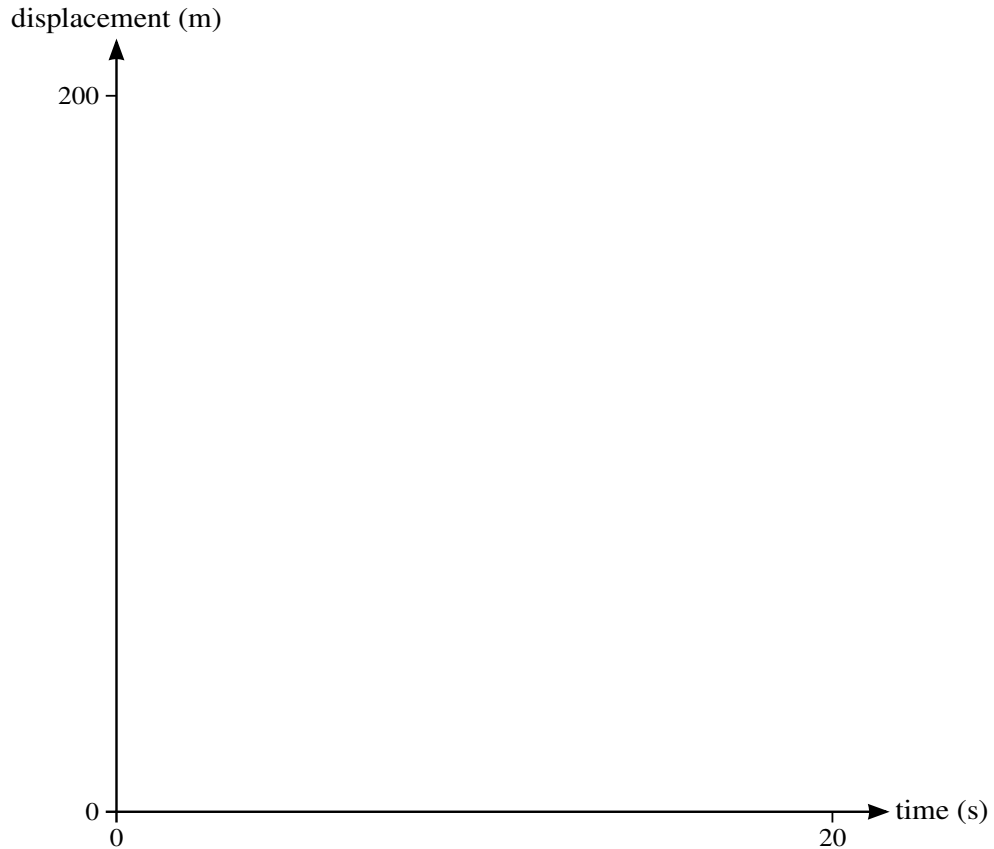

- (ii) Find the value of V .

[2]

32. [9709/s18/43/q1]

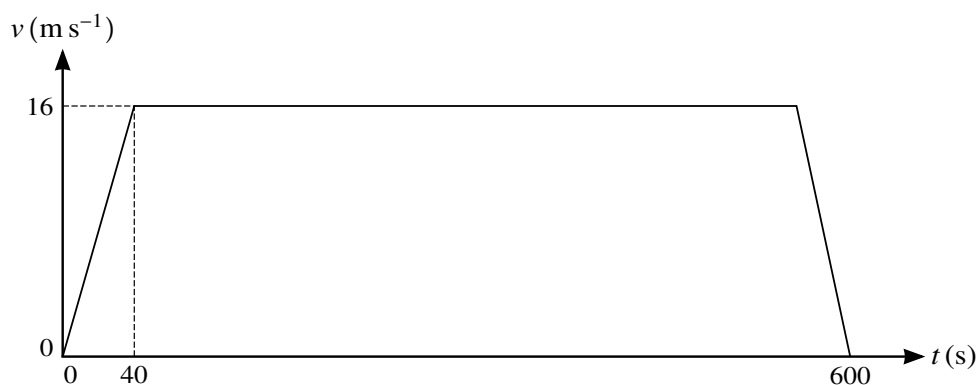

The diagram shows the velocity-time graph for a train which travels from rest at one station to rest at the next station. The graph consists of three straight line segments. The distance between the two stations is 9040 m.

- (i) Find the acceleration of the train during the first 40 s. [1]
- (ii) Find the length of time for which the train is travelling at constant speed. [2]
- (iii) Find the distance travelled by the train while it is decelerating. [2]

33. [9709/w18/42/q3]

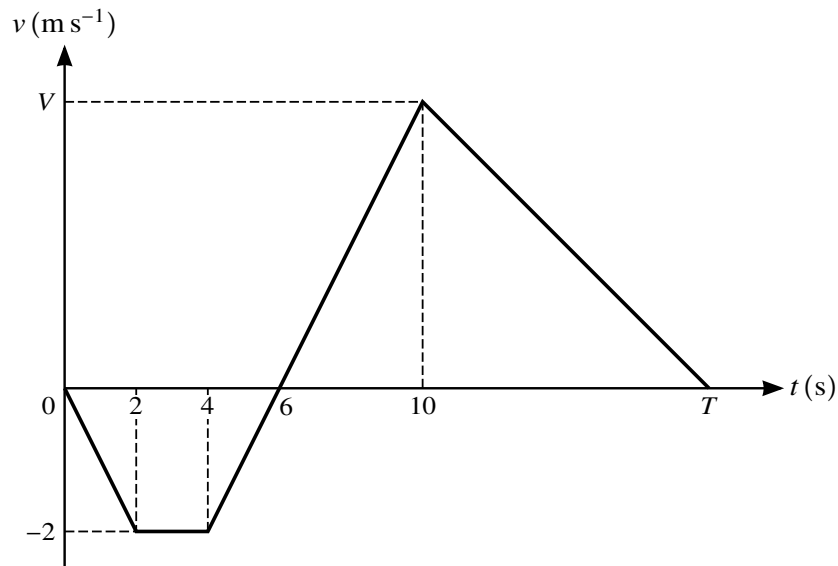

The velocity of a particle moving in a straight line is $v \text{ m s}^{-1}$ at time t seconds. The diagram shows a velocity-time graph which models the motion of the particle from $t = 0$ to $t = T$. The graph consists of four straight line segments. The particle reaches its maximum velocity $V \text{ m s}^{-1}$ at $t = 10$.

(i) Find the acceleration of the particle during the first 2 seconds. [1]

(ii) Find the value of V . [2]

At $t = 6$, the particle is instantaneously at rest at the point A . At $t = T$, the particle comes to rest at the point B . At $t = 0$ the particle starts from rest at a point one third of the way from A to B .

(iii) Find the distance AB and hence find the value of T . [4]

34. [9709/w18/43/q4]

A runner sets off from a point P at time $t = 0$, where t is in seconds. The runner starts from rest and accelerates at 1.2 m s^{-2} for 5 s. For the next 12 s the runner moves at constant speed before decelerating uniformly over a period of 3 s, coming to rest at Q . A cyclist sets off from P at time $t = 10$ and accelerates uniformly for 10 s, before immediately decelerating uniformly to rest at Q at time $t = 30$.

- (i) Sketch the velocity-time graph for the runner and show that the distance PQ is 96 m. [4]

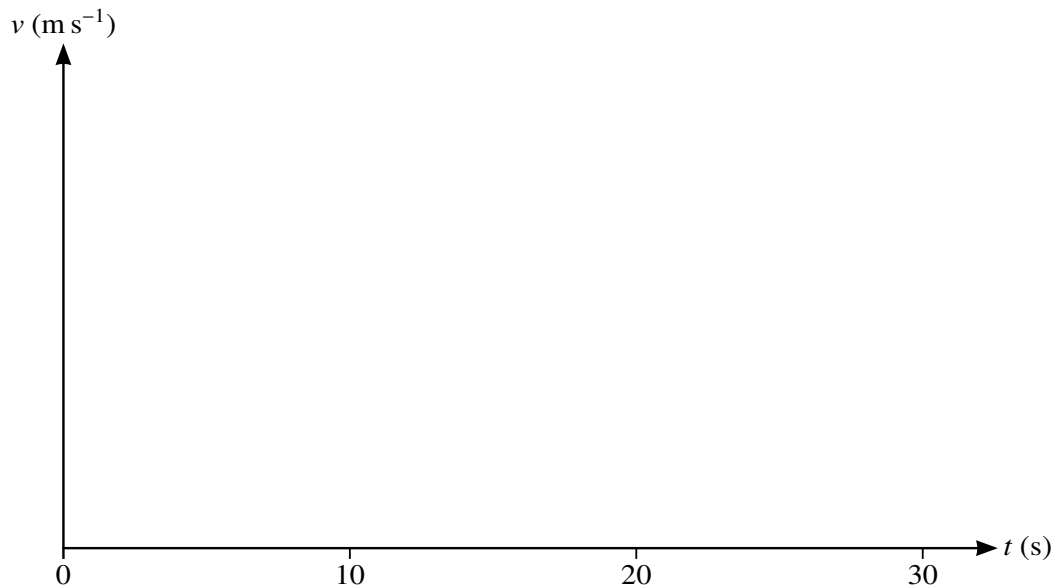

- (ii) Find the magnitude of the acceleration of the cyclist. [3]

35. [9709/s17/43/q3]

A train travels between two stations, A and B . The train starts from rest at A and accelerates at a constant rate for T s until it reaches a speed of 25 m s^{-1} . It then travels at this constant speed before decelerating at a constant rate, coming to rest at B . The magnitude of the train's deceleration is twice the magnitude of its acceleration. The total time taken for the journey is 180 s.

- (i) Sketch the velocity-time graph for the train's journey from A to B . [1]



- (ii) Find an expression, in terms of T , for the length of time for which the train is travelling with constant speed. [2]
- (iii) The distance from A to B is 3300 m. Find how far the train travels while it is decelerating. [3]

36. [9709/w17/41/q4]

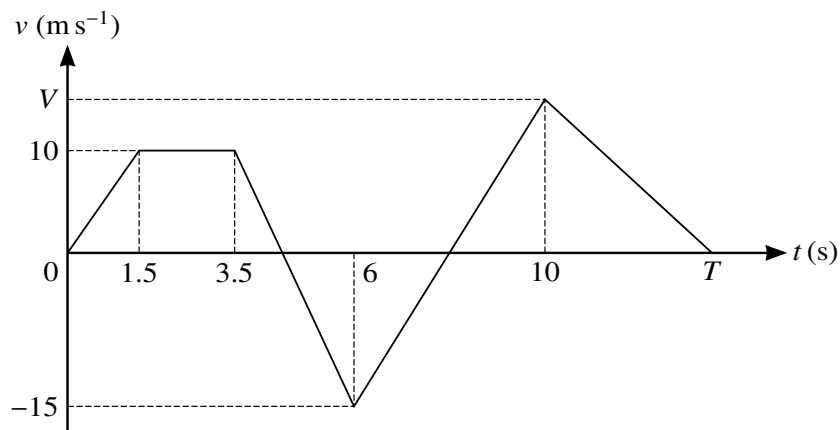

The diagram shows the velocity-time graph of a particle which moves in a straight line. The graph consists of 5 straight line segments. The particle starts from rest at a point A at time $t = 0$, and initially travels towards point B on the line.

- (i) Show that the acceleration of the particle between $t = 3.5$ and $t = 6$ is -10 m s^{-2} . [1]
- (ii) The acceleration of the particle between $t = 6$ and $t = 10$ is 7.5 m s^{-2} . When $t = 10$ the velocity of the particle is $V \text{ m s}^{-1}$. Find the value of V . [2]
- (iii) The particle comes to rest at B at time T s. Given that the total distance travelled by the particle between $t = 0$ and $t = T$ is 100 m, find the value of T . [4]

37. [9709/w17/43/q6]

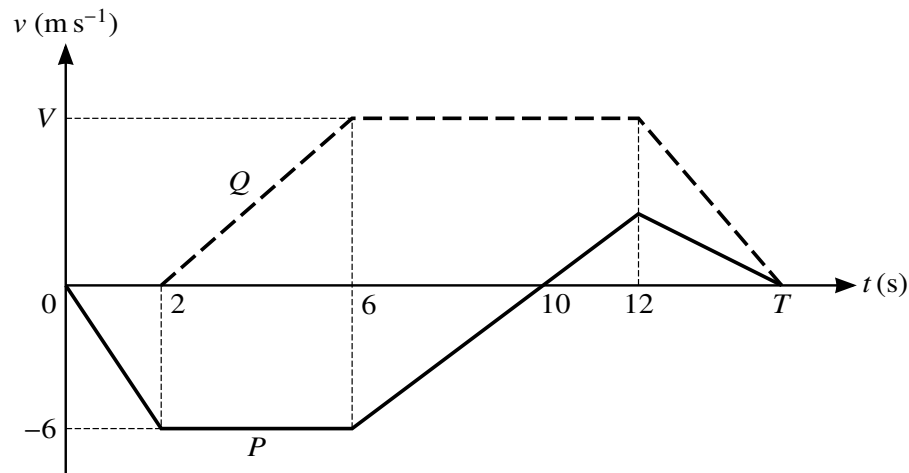

The diagram shows the velocity-time graphs for two particles, P and Q , which are moving in the same straight line. The graph for P consists of four straight line segments. The graph for Q consists of three straight line segments. Both particles start from the same initial position O on the line. Q starts 2 seconds after P and both particles come to rest at time $t = T$. The greatest velocity of Q is $V \text{ m s}^{-1}$.

- (i) Find the displacement of P from O at $t = 10$. [1]
- (ii) Find the velocity of P at $t = 12$. [2]
- (iii) Given that the total distance covered by P during the T seconds of its motion is 49.5 m, find the value of T . [3]
- (iv) Given also that the acceleration of Q from $t = 2$ to $t = 6$ is 1.75 m s^{-2} , find the value of V and hence find the distance between the two particles when they both come to rest at $t = T$. [3]

38. [9709/s16/41/q1]

A lift moves upwards from rest and accelerates at 0.9 m s^{-2} for 3 s. The lift then travels for 6 s at constant speed and finally slows down, with a constant deceleration, stopping in a further 4 s.

(i) Sketch a velocity-time graph for the motion. [3]

(ii) Find the total distance travelled by the lift. [2]

39. [9709/s16/42/q4]

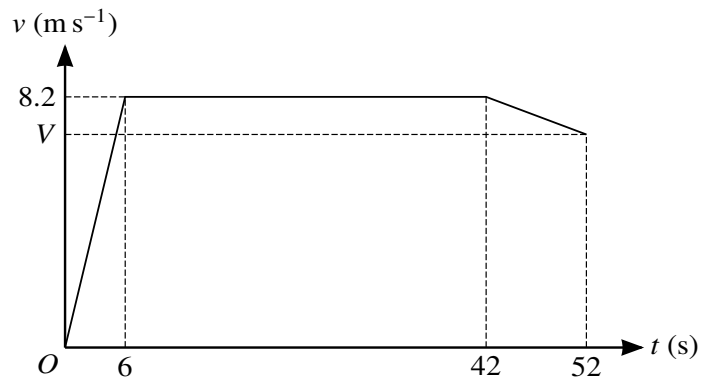

A sprinter runs a race of 400 m. His total time for running the race is 52 s. The diagram shows the velocity-time graph for the motion of the sprinter. He starts from rest and accelerates uniformly to a speed of 8.2 m s^{-1} in 6 s. The sprinter maintains a speed of 8.2 m s^{-1} for 36 s, and he then decelerates uniformly to a speed of $V \text{ m s}^{-1}$ at the end of the race.

- (i) Calculate the distance covered by the sprinter in the first 42 s of the race. [2]
- (ii) Show that $V = 7.84$. [3]
- (iii) Calculate the deceleration of the sprinter in the last 10 s of the race. [2]

40. [9709/w16/41/q5]

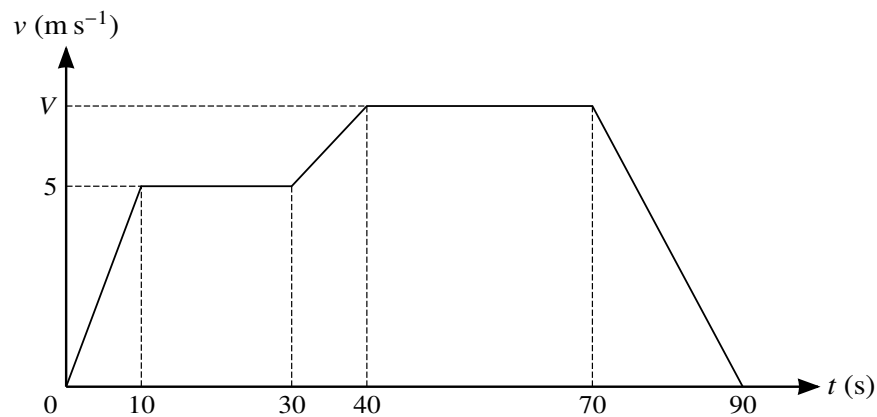

The diagram shows a velocity-time graph which models the motion of a cyclist. The graph consists of five straight line segments. The cyclist accelerates from rest to a speed of 5 m s^{-1} over a period of 10 s, and then travels at this speed for a further 20 s. The cyclist then descends a hill, accelerating to speed $V \text{ m s}^{-1}$ over a period of 10 s. This speed is maintained for a further 30 s. The cyclist then decelerates to rest over a period of 20 s.

- (i) Find the acceleration of the cyclist during the first 10 seconds. [1]
- (ii) Show that the total distance travelled by the cyclist in the 90 seconds of motion may be expressed as $(45V + 150) \text{ m}$. Hence find V , given that the total distance travelled by the cyclist is 465 m. [3]
- (iii) The combined mass of the cyclist and the bicycle is 80 kg. The cyclist experiences a constant resistance to motion of 20 N. Use an energy method to find the vertical distance which the cyclist descends during the downhill section from $t = 30$ to $t = 40$, assuming that the cyclist does no work during this time. [4]

Chapter 2

Variable acceleration in one dimension

1. [9709/m25/42/q7]

A particle moves in a straight line. The velocity $v \text{ m s}^{-1}$ of the particle t s after leaving a fixed point O is given by $v = k(20 + pt - 6t^2)$, where k and p are constants. The acceleration of the particle at $t = 1$ is 42 m s^{-2} , and the displacement of the particle from O at $t = 1$ is 93 m .

- (a) Show that $k = 3$ and $p = 26$. [6]
- (b) Find the distance moved by the particle between the time at which its acceleration is zero and the time at which its velocity is zero. [5]

2. [9709/s25/41/q7]

A particle X moves along a straight track, starting from a point O at time $t = 0$. The displacement of X from O at time t s is s m, where $s = 3t^{\frac{3}{2}} - 6t$.

- (a) Find the time at which X is instantaneously at rest, and hence find the total distance travelled by X between $t = 0$ and $t = 16$. [6]

A second particle Y moves along another straight track, starting from a point P at time $t = 0$. The acceleration of Y at time t s is $a \text{ ms}^{-2}$, where $a = 0.8 - 0.6t$. The velocity of Y when it leaves P is 7.5 ms^{-1} .

- (b) When the velocity of Y is -9.6 ms^{-1} , show that the displacement of X from O is equal to the displacement of Y from P . [7]

3. [9709/s25/42/q6]

A particle P moves in a straight line and passes through the point A at time $t = 0$. The velocity $v \text{ ms}^{-1}$ of P at time t seconds is given by

$$v = (2t + 1)^{\frac{3}{2}} - 2t^2, \text{ where } 0 \leq t \leq 3.$$

(a) Find the maximum velocity of P in the interval $0 \leq t \leq 3$. [5]

It is given that in the interval $0 \leq t \leq 3$ the velocity of P is always positive.

(b) Find the distance of P from A at the instant when P is moving at this maximum velocity. [4]

4. [9709/s25/43/q7]

A particle X moves in a straight line. The displacement of X from O at time t s after leaving O is s m, where $s = 0.3t^2 + 0.6t$ for $0 \leq t \leq 4$.

(a) Find the velocity of X at $t = 4$. [2]

For $t > 4$, the acceleration of X at time t s after leaving O is $a \text{ ms}^{-2}$, where $a = 0.3t^{\frac{1}{2}}$. There is no change in the velocity of X at $t = 4$. The velocity of X at $t = T$ is 14.2 ms^{-1} .

(b) (i) Find the value of T . [4]

(ii) Find the total distance travelled by X between $t = 0$ and $t = T$. [4]

5. [9709/s25/45/q6]

A particle P moves in a straight line starting from a point O . At time t s after leaving O , the velocity, v ms^{-1} , of P is given by $v = (15 - 2t)^2$.

- (a) Find the values of t when the velocity of P is 100 m s^{-1} . [2]
- (b) Show that there is a particular value of t for which the velocity and acceleration of the particle are both zero. [3]
- (c) Find the displacement of P from O at the time that the velocity and acceleration of the particle are both zero. [4]

6. [9709/w25/41/q7]

A particle P starts from a point O and moves in a straight line. The velocity $v \text{ m s}^{-1}$ of P , at time t s after leaving O , is given by $v = \frac{1}{3}(2t-3)(t-4)$.

- (a) Find the acceleration of P when $t = 2$. [2]
- (b) Find the total distance travelled by P in the first 3 seconds of its motion. [5]
- (c) Determine whether P returns to O . [2]

7. [9709/w25/42/q6]

A particle starts from rest at a point O . The acceleration of the particle at time t s after leaving O is $a \text{ ms}^{-2}$, where

$$a = 2(t+1)^{-\frac{1}{2}} - 1 \text{ for } t \geq 0.$$

Find the distance that the particle travels from O until the time at which its acceleration is zero. [8]

8. [9709/w25/43/q4]

A particle P moves in a straight line. At time t s after passing through a point O on the line, the displacement of P from O is s m, where $s = 0.01t^3 - 0.3t^2 - 2.07t$.

- (a) Find the value of s when P has its minimum velocity, and find also the speed of P at this instant. [6]
- (b) Find the acceleration of P at the instant when the direction of motion of P changes. [4]

9. [9709/w25/45/q4]

A particle P moves in a straight line. At time t s after leaving a point O on the line, the acceleration a ms^{-2} of P is given by $a = kt - 3$, where k is a positive constant. At time $t = 0$, the velocity of P is 1 ms^{-1} .

(a) Given that P is never at instantaneous rest, show that $k > 4.5$. [4]

(b) Given instead that $k = 2.5$, find the total distance travelled by P in the interval $1 \leq t \leq 3$. [6]

10. [9709/m24/42/q5]

A particle moves in a straight line starting from a point O . The velocity $v \text{ m s}^{-1}$ of the particle t s after leaving O is given by

$$v = t^3 - \frac{9}{2}t^2 + 1 \text{ for } 0 \leq t \leq 4.$$

You may assume that the velocity of the particle is positive for $t < \frac{1}{2}$, is zero at $t = \frac{1}{2}$ and is negative for $t > \frac{1}{2}$.

- (a) Find the distance travelled between $t = 0$ and $t = \frac{1}{2}$. [4]
- (b) Find the positive value of t at which the acceleration is zero. Hence find the total distance travelled between $t = 0$ and this instant. [4]

11. [9709/s24/41/q6]

A particle moves in a straight line, starting from a point O . The velocity of the particle at time t s after leaving O is v ms⁻¹. It is given that $v = kt^{\frac{1}{2}} - 2t - 8$, where k is a positive constant. The maximum velocity of the particle is 4.5 ms⁻¹.

- (a) Show that $k = 10$. [5]
- (b) (i) Verify that $v = 0$ when $t = 1$ and $t = 16$. [1]
- (ii) Find the distance travelled by the particle in the first 16 s. [5]

12. [9709/s24/42/q2]

A particle P moves in a straight line. At time t s after leaving a point O on the line, P has velocity v ms⁻¹, where $v = 44t - 6t^2 - 36$.

- (a) Find the set of values of t for which the acceleration of the particle is positive. [2]
- (b) Find the two values of t at which P returns to O . [3]

13. [9709/s24/43/q4]

A particle travels in a straight line. The velocity of the particle at time t s after leaving a point O is v m s⁻¹, where

$$v = kt^2 - 4t + 3.$$

The distance travelled by the particle in the first 2 s of its motion is 6 m. You may assume that $v > 0$ in the first 2 s of its motion.

- (a) Find the value of k . [4]
- (b) Find the value of the minimum velocity of the particle. You do **not** need to show that this velocity is a minimum. [3]

14. [9709/w24/41/q8]

A particle P moves in a straight line, passing through a point O with velocity 4.2 m s^{-1} . At time t s after P passes O , the acceleration, $a \text{ m s}^{-2}$, of P is given by $a = 0.6t - 2.7$.

Find the distance P travels between the times at which it is at instantaneous rest.

[7]

15. [9709/w24/42/q6]

A particle, P , travels in a straight line, starting from a point O with velocity 6 m s^{-1} . The acceleration of P at time t s after leaving O is $a \text{ m s}^{-2}$, where

$$a = -1.5t^{\frac{1}{2}} \quad \text{for } 0 \leq t \leq 1,$$

$$a = 1.5t^{\frac{1}{2}} - 3t^{-\frac{1}{2}} \quad \text{for } t > 1.$$

- (a) Find the velocity of P at $t = 1$. [3]
- (b) Given that there is no change in the velocity of P when $t = 1$, find an expression for the velocity of P for $t > 1$. [3]
- (c) Given that the velocity of P is positive for $t \leq 4$, find the total distance travelled between $t = 0$ and $t = 4$. [4]

16. [9709/m23/42/q3]

A particle moves in a straight line starting from rest from a point O . The acceleration of the particle at time t s after leaving O is $a \text{ m s}^{-2}$, where $a = 4t^{\frac{1}{2}}$.

(a) Find the speed of the particle when $t = 9$. [2]

(b) Find the time after leaving O at which the speed (in metres per second) and the distance travelled (in metres) are numerically equal. [3]

17. [9709/s23/41/q3]

A particle moves in a straight line starting from rest. The displacement s m of the particle from a fixed point O on the line at time t s is given by

$$s = t^{\frac{5}{2}} - \frac{15}{4}t^{\frac{3}{2}} + 6.$$

Find the value of s when the particle is again at rest.

[4]

18. [9709/s23/42/q6]

A particle P starts at rest and moves in a straight line from a point O . At time t s after leaving O , the velocity of P , v m s^{-1} , is given by $v = bt + ct^{\frac{3}{2}}$, where b and c are constants. P has velocity 8 m s^{-1} when $t = 4$ and has velocity 13.5 m s^{-1} when $t = 9$.

- (a) Show that $b = 3$ and $c = -0.5$. [1]
- (b) Find the acceleration of P when $t = 1$. [2]
- (c) Find the positive value of t when P is at instantaneous rest and find the distance of P from O at this instant. [5]
- (d) Find the speed of P at the instant it returns to O . [3]

19. [9709/s23/43/q5]

A particle starts from rest from a point O and moves in a straight line. The acceleration of the particle at time t s after leaving O is $a \text{ m s}^{-2}$, where $a = kt^{\frac{1}{2}}$ for $0 \leq t \leq 9$ and where k is a constant. The velocity of the particle at $t = 9$ is 1.8 m s^{-1} .

(a) Show that $k = 0.1$. [3]

For $t > 9$, the velocity $v \text{ m s}^{-1}$ of the particle is given by $v = 0.2(t - 9)^2 + 1.8$.

(b) Show that the distance travelled in the first 9 seconds is one tenth of the distance travelled between $t = 9$ and $t = 18$. [4]

(c) Find the greatest acceleration of the particle during the first 10 seconds of its motion. [3]

20. [9709/w23/41/q7]

A particle moves in a straight line starting from a point O before coming to instantaneous rest at a point X . At time t s after leaving O , the velocity v m s⁻¹ of the particle is given by

$$v = 7.2t^2 \quad 0 \leq t \leq 2,$$

$$v = 30.6 - 0.9t \quad 2 \leq t \leq 8,$$

$$v = \frac{1600}{t^2} + kt \quad 8 \leq t,$$

where k is a constant. It is given that there is no instantaneous change in velocity at $t = 8$.

Find the distance OX .

[9]

21. [9709/w23/42/q7]

A particle X travels in a straight line. The velocity of X at time t s after leaving a fixed point O is denoted by v m s⁻¹, where

$$v = -0.1t^3 + 1.8t^2 - 6t + 5.6.$$

The acceleration of X is zero at $t = p$ and $t = q$, where $p < q$.

(a) Find the value of p and the value of q . [4]

It is given that the velocity of X is zero at $t = 14$.

(b) Find the velocities of X at $t = p$ and at $t = q$, and hence sketch the velocity-time graph for the motion of X for $0 \leq t \leq 15$. [3]

(c) Find the total distance travelled by X between $t = 0$ and $t = 15$. [5]

22. [9709/w23/43/q6]

A particle moves in a straight line. At time t s, the acceleration, $a \text{ m s}^{-2}$, of the particle is given by $a = 36 - 6t$. The velocity of the particle is 27 m s^{-1} when $t = 2$.

- (a) Find the values of t when the particle is at instantaneous rest. [4]
- (b) Find the total distance the particle travels during the first 12 seconds. [4]

23. [9709/m22/42/q6]

A cyclist starts from rest at a fixed point O and moves in a straight line, before coming to rest k seconds later. The acceleration of the cyclist at time t s after leaving O is $a \text{ m s}^{-2}$, where $a = 2t^{-\frac{1}{2}} - \frac{3}{5}t^{\frac{1}{2}}$ for $0 < t \leq k$.

- (a) Find the value of k . [4]
- (b) Find the maximum speed of the cyclist. [3]
- (c) Find an expression for the displacement from O in terms of t . Hence find the total distance travelled by the cyclist from the time at which she reaches her maximum speed until she comes to rest. [4]

24. [9709/s22/41/q6]

A particle starts from a point O and moves in a straight line. The velocity $v \text{ m s}^{-1}$ of the particle at time $t \text{ s}$ after leaving O is given by

$$v = k(3t^2 - 2t^3),$$

where k is a constant.

(a) Verify that the particle returns to O when $t = 2$. [4]

(b) It is given that the acceleration of the particle is -13.5 m s^{-2} for the positive value of t at which $v = 0$.

Find k and hence find the total distance travelled in the first two seconds of motion. [6]

25. [9709/s22/42/q7]

A particle P moves in a straight line. The velocity $v \text{ m s}^{-1}$ at time t seconds is given by

$$\begin{aligned}v &= 0.5t && \text{for } 0 \leq t \leq 10, \\v &= 0.25t^2 - 8t + 60 && \text{for } 10 \leq t \leq 20.\end{aligned}$$

(a) Show that there is an instantaneous change in the acceleration of the particle at $t = 10$. [3]

(b) Find the total distance covered by P in the interval $0 \leq t \leq 20$. [6]

26. [9709/s22/43/q7]

A particle P moves in a straight line through a point O . The velocity $v \text{ m s}^{-1}$ of P , at time $t \text{ s}$ after passing O , is given by

$$v = \frac{9}{4} + \frac{b}{(t+1)^2} - ct^2,$$

where b and c are positive constants. At $t = 5$, the velocity of P is zero and its acceleration is $-\frac{13}{12} \text{ m s}^{-2}$.

- (a) Show that $b = 9$ and find the value of c . [5]
- (b) Given that the velocity of P is zero only at $t = 5$, find the distance travelled in the first 10 seconds of motion. [5]

27. [9709/w22/41/q5]

A particle P moves on the x -axis from the origin O with an initial velocity of -20 m s^{-1} . The acceleration $a \text{ m s}^{-2}$ at time $t \text{ s}$ after leaving O is given by $a = 12 - 2t$.

(a) Sketch a velocity-time graph for $0 \leq t \leq 12$, indicating the times when P is at rest. [5]

(b) Find the total distance travelled by P in the interval $0 \leq t \leq 12$. [5]

28. [9709/w22/42/q7]

A particle P travels in a straight line, starting at rest from a point O . The acceleration of P at time t s after leaving O is denoted by $a \text{ m s}^{-2}$, where

$$\begin{aligned} a &= 0.3t^{\frac{1}{2}} && \text{for } 0 \leq t \leq 4, \\ a &= -kt^{-\frac{3}{2}} && \text{for } 4 < t \leq T, \end{aligned}$$

where k and T are constants.

- (a) Find the velocity of P at $t = 4$. [2]
- (b) It is given that there is no change in the velocity of P at $t = 4$ and that the velocity of P at $t = 16$ is 0.3 m s^{-1} .

Show that $k = 2.6$ and find an expression, in terms of t , for the velocity of P for $4 \leq t \leq T$. [4]

- (c) Given that P comes to instantaneous rest at $t = T$, find the exact value of T . [2]
- (d) Find the total distance travelled between $t = 0$ and $t = T$. [4]

29. [9709/w22/43/q5]

Particles X and Y move in a straight line through points A and B . Particle X starts from rest at A and moves towards B . At the same instant, Y starts from rest at B .

At time t seconds after the particles start moving

- the acceleration of X in the direction AB is given by $(12t + 12) \text{ m s}^{-2}$,
- the acceleration of Y in the direction AB is given by $(24t - 8) \text{ m s}^{-2}$.

(a) It is given that the velocities of X and Y are equal when they collide.

Calculate the distance AB .

[6]

(b) It is given instead that $AB = 36 \text{ m}$.

Verify that X and Y collide after 3 s.

[2]

30. [9709/m21/42/q6]

A particle moves in a straight line. It starts from rest from a fixed point O on the line. Its velocity at time t s after leaving O is v m s⁻¹, where $v = t^2 - 8t^{\frac{3}{2}} + 10t$.

(a) Find the displacement of the particle from O when $t = 1$. [4]

(b) Show that the minimum velocity of the particle is -125 m s⁻¹. [7]

31. [9709/s21/41/q5]

A particle moving in a straight line starts from rest at a point A and comes instantaneously to rest at a point B . The acceleration of the particle at time t s after leaving A is $a \text{ m s}^{-2}$, where

$$a = 6t^{\frac{1}{2}} - 2t.$$

- (a) Find the value of t at point B . [3]
- (b) Find the distance travelled from A to the point at which the acceleration of the particle is again zero. [5]

32. [9709/s21/42/q7]

A particle P moving in a straight line starts from rest at a point O and comes to rest 16 s later. At time t s after leaving O , the acceleration $a \text{ m s}^{-2}$ of P is given by

$$a = 6 + 4t \quad 0 \leq t < 2,$$

$$a = 14 \quad 2 \leq t < 4,$$

$$a = 16 - 2t \quad 4 \leq t \leq 16.$$

There is no sudden change in velocity at any instant.

(a) Find the values of t when the velocity of P is 55 m s^{-1} . [5]

(b) Complete the sketch of the velocity-time diagram. [2]

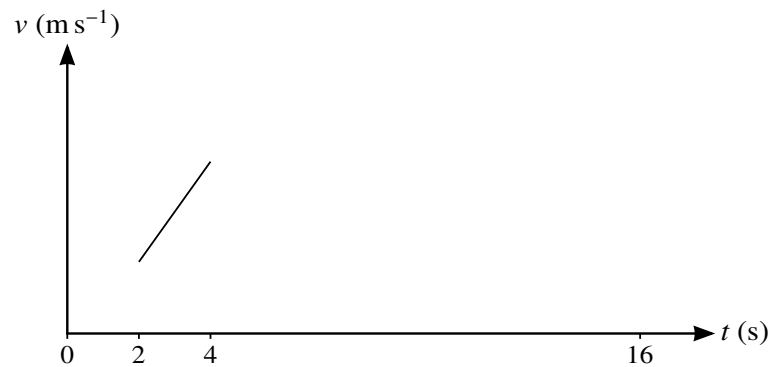

(c) Find the distance travelled by P when it is decelerating. [3]

33. [9709/s21/43/q6]

A particle moves in a straight line and passes through the point A at time $t = 0$. The velocity of the particle at time t s after leaving A is v m s⁻¹, where

$$v = 2t^2 - 5t + 3.$$

- (a) Find the times at which the particle is instantaneously at rest. Hence or otherwise find the minimum velocity of the particle. [4]
- (b) Sketch the velocity-time graph for the first 3 seconds of motion. [3]
- (c) Find the distance travelled between the two times when the particle is instantaneously at rest. [3]

34. [9709/w21/41/q6]

A particle P moves in a straight line starting from a point O and comes to rest 14 s later. At time t s after leaving O , the velocity $v \text{ m s}^{-1}$ of P is given by

$$\begin{aligned}v &= pt^2 - qt & 0 \leq t \leq 6, \\v &= 63 - 4.5t & 6 \leq t \leq 14,\end{aligned}$$

where p and q are positive constants.

The acceleration of P is zero when $t = 2$.

- (a) Given that there are no instantaneous changes in velocity, find p and q . [3]
- (b) Sketch the velocity-time graph. [3]
- (c) Find the total distance travelled by P during the 14 s. [5]

35. [9709/w21/42/q4]

A cyclist starts from rest at a point A and travels along a straight road AB , coming to rest at B . The displacement of the cyclist from A at time t s after the start is s m, where

$$s = 0.004(75t^2 - t^3).$$

- (a) Show that the distance AB is 250 m. [4]
- (b) Find the maximum velocity of the cyclist. [3]

36. [9709/w21/43/q5]

A particle P moves in a straight line, starting from rest at a point O on the line. At time t s after leaving O the acceleration of P is $k(16 - t^2)$ m s⁻², where k is a positive constant, and the displacement from O is s m. The velocity of P is 8 m s⁻¹ when $t = 4$.

- (a) Show that $s = \frac{1}{64}t^2(96 - t^2)$. [5]
- (b) Find the speed of P at the instant that it returns to O . [3]
- (c) Find the maximum displacement of the particle from O . [3]

37. [9709/m20/42/q7]

A particle moves in a straight line through the point O . The displacement of the particle from O at time t s is s m, where

$$s = t^2 - 3t + 2 \quad \text{for } 0 \leq t \leq 6,$$

$$s = \frac{24}{t} - \frac{t^2}{4} + 25 \quad \text{for } t \geq 6.$$

- (a) Find the value of t when the particle is instantaneously at rest during the first 6 seconds of its motion. [2]

At $t = 6$, the particle hits a barrier at a point P and rebounds.

- (b) Find the velocity with which the particle arrives at P and also the velocity with which the particle leaves P . [3]
- (c) Find the total distance travelled by the particle in the first 10 seconds of its motion. [5]

38. [9709/s20/41/q6]

A particle moves in a straight line AB . The velocity $v \text{ m s}^{-1}$ of the particle $t \text{ s}$ after leaving A is given by $v = k(t^2 - 10t + 21)$, where k is a constant. The displacement of the particle from A , in the direction towards B , is 2.85 m when $t = 3$ and is 2.4 m when $t = 6$.

- (a) Find the value of k . Hence find an expression, in terms of t , for the displacement of the particle from A . [7]
- (b) Find the displacement of the particle from A when its velocity is a minimum. [4]

39. [9709/s20/42/q6]

A particle P moves in a straight line. The velocity $v \text{ m s}^{-1}$ at time $t \text{ s}$ is given by

$$\begin{aligned}v &= 2t + 1 && \text{for } 0 \leq t \leq 5, \\v &= 36 - t^2 && \text{for } 5 \leq t \leq 7, \\v &= 2t - 27 && \text{for } 7 \leq t \leq 13.5.\end{aligned}$$

- (a) Sketch the velocity-time graph for $0 \leq t \leq 13.5$. [3]
- (b) Find the acceleration at the instant when $t = 6$. [2]
- (c) Find the total distance travelled by P in the interval $0 \leq t \leq 13.5$. [5]

40. [9709/s20/43/q6]

A particle travels in a straight line PQ . The velocity of the particle t s after leaving P is v m s⁻¹, where

$$v = 4.5 + 4t - 0.5t^2.$$

(a) Find the velocity of the particle at the instant when its acceleration is zero. [3]

The particle comes to instantaneous rest at Q .

(b) Find the distance PQ . [6]

41. [9709/w20/41/q4]

A particle P moves in a straight line. It starts from rest at a point O on the line and at time t s after leaving O it has acceleration a m s⁻², where $a = 6t - 18$.

Find the distance P moves before it comes to instantaneous rest.

[6]

42. [9709/w20/42/q7]

A particle P moves in a straight line, starting from a point O with velocity 1.72 m s^{-1} . The acceleration $a \text{ m s}^{-2}$ of the particle, $t \text{ s}$ after leaving O , is given by $a = 0.1t^{\frac{3}{2}}$.

(a) Find the value of t when the velocity of P is 3 m s^{-1} . [4]

(b) Find the displacement of P from O when $t = 2$, giving your answer correct to 2 decimal places. [3]

43. [9709/w20/43/q5]

A particle P moves in a straight line. It starts at a point O on the line and at time t s after leaving O it has velocity v m s⁻¹, where $v = 4t^2 - 20t + 21$.

- (a) Find the values of t for which P is at instantaneous rest. [2]
- (b) Find the initial acceleration of P . [2]
- (c) Find the minimum velocity of P . [2]
- (d) Find the distance travelled by P during the time when its velocity is negative. [4]

44. [9709/m19/42/q6]

A particle moves in a straight line. It starts from rest at a fixed point O on the line. Its acceleration at time t s after leaving O is $a \text{ m s}^{-2}$, where $a = 0.4t^3 - 4.8t^{\frac{1}{2}}$.

- (i) Show that, in the subsequent motion, the acceleration of the particle when it comes to instantaneous rest is 16 m s^{-2} . [6]
- (ii) Find the displacement of the particle from O at $t = 5$. [3]

45. [9709/s19/41/q5]

A particle P moves in a straight line from a fixed point O . The velocity $v \text{ m s}^{-1}$ of P at time $t \text{ s}$ is given by

$$v = t^2 - 8t + 12 \quad \text{for } 0 \leq t \leq 8.$$

(i) Find the minimum velocity of P . [3]

(ii) Find the total distance travelled by P in the interval $0 \leq t \leq 8$. [7]

46. [9709/s19/42/q2]

A car moves in a straight line with initial speed $u \text{ m s}^{-1}$ and constant acceleration $a \text{ m s}^{-2}$. The car takes 5 s to travel the first 80 m and it takes 8 s to travel the first 160 m. Find a and u . [6]

47. [9709/s19/42/q7]

Particles P and Q leave a fixed point A at the same time and travel in the same straight line. The velocity of P after t seconds is $6t(t - 3) \text{ m s}^{-1}$ and the velocity of Q after t seconds is $(10 - 2t) \text{ m s}^{-1}$.

- (i) Sketch, on the same axes, velocity-time graphs for P and Q for $0 \leq t \leq 5$. [3]
- (ii) Verify that P and Q meet after 5 seconds. [4]
- (iii) Find the greatest distance between P and Q for $0 \leq t \leq 5$. [4]

48. [9709/s19/43/q6]

A particle P moves in a straight line. The acceleration $a \text{ m s}^{-2}$ of P at time $t \text{ s}$ is given by $a = 6t - 12$. The displacement of P from a fixed point O on the line is $s \text{ m}$. It is given that $s = 5$ when $t = 1$ and $s = 1$ when $t = 3$.

- (i) Show that $s = t^3 - 6t^2 + pt + q$, where p and q are constants to be found. [4]
- (ii) Find the values of t when P is at instantaneous rest. [2]
- (iii) Find the total distance travelled by P in the interval $0 \leq t \leq 4$. [4]

49. [9709/w19/41/q7]

A particle moves in a straight line, starting from rest at a point O , and comes to instantaneous rest at a point P . The velocity of the particle at time t s after leaving O is v m s⁻¹, where

$$v = 0.6t^2 - 0.12t^3.$$

(i) Show that the distance OP is 6.25 m. [5]

On another occasion, the particle also moves in the same straight line. On this occasion, the displacement of the particle at time t s after leaving O is s m, where

$$s = kt^3 + ct^5.$$

It is given that the particle passes point P with velocity 1.25 m s⁻¹ at time $t = 5$.

(ii) Find the values of the constants k and c . [5]

(iii) Find the acceleration of the particle at time $t = 5$. [2]

50. [9709/w19/42/q1]

A particle moves in a straight line. The displacement of the particle at time t s is s m, where

$$s = t^3 - 6t^2 + 4t.$$

Find the velocity of the particle at the instant when its acceleration is zero.

[4]

51. [9709/w19/43/q6]

Particle P travels in a straight line from A to B . The velocity of P at time t s after leaving A is denoted by v m s⁻¹, where

$$v = 0.04t^3 + ct^2 + kt.$$

P takes 5 s to travel from A to B and it reaches B with speed 10 m s⁻¹. The distance AB is 25 m.

(i) Find the values of the constants c and k . [6]

(ii) Show that the acceleration of P is a minimum when $t = 2.5$. [3]

52. [9709/m18/42/q7]

A particle P moves in a straight line. The velocity $v \text{ m s}^{-1}$ at time $t \text{ s}$ is given by

$$v = 4 + 0.2t \quad \text{for } 0 \leq t \leq 10,$$
$$v = -2 + \frac{800}{t^2} \quad \text{for } 10 \leq t \leq 20.$$

- (i) Find the acceleration of P during the first 10 s. [1]
- (ii) Find the acceleration of P when $t = 20$. [2]
- (iii) Sketch the velocity-time graph for $0 \leq t \leq 20$. [3]
- (iv) Find the total distance travelled by P in the interval $0 \leq t \leq 20$. [5]

53. [9709/s18/41/q4]

A particle P moves in a straight line starting from a point O . At time t s after leaving O , the displacement s m from O is given by $s = t^3 - 4t^2 + 4t$ and the velocity is v m s⁻¹.

- (i) Find an expression for v in terms of t . [2]
- (ii) Find the two values of t for which P is at instantaneous rest. [2]
- (iii) Find the minimum velocity of P . [3]

54. [9709/s18/42/q6]

A particle P moves in a straight line passing through a point O . At time t s, the acceleration, a m s⁻², of P is given by $a = 6 - 0.24t$. The particle comes to instantaneous rest at time $t = 20$.

(i) Find the value of t at which the particle is again at instantaneous rest. [5]

(ii) Find the distance the particle travels between the times of instantaneous rest. [3]

55. [9709/s18/43/q7]

A particle P moves in a straight line starting from a point O . The velocity $v \text{ m s}^{-1}$ of P at time $t \text{ s}$ is given by

$$v = 12t - 4t^2 \quad \text{for } 0 \leq t \leq 2,$$

$$v = 16 - 4t \quad \text{for } 2 \leq t \leq 4.$$

- (i) Find the maximum velocity of P during the first 2 s. [3]
- (ii) Determine, with justification, whether there is any instantaneous change in the acceleration of P when $t = 2$. [2]
- (iii) Sketch the velocity-time graph for $0 \leq t \leq 4$. [3]

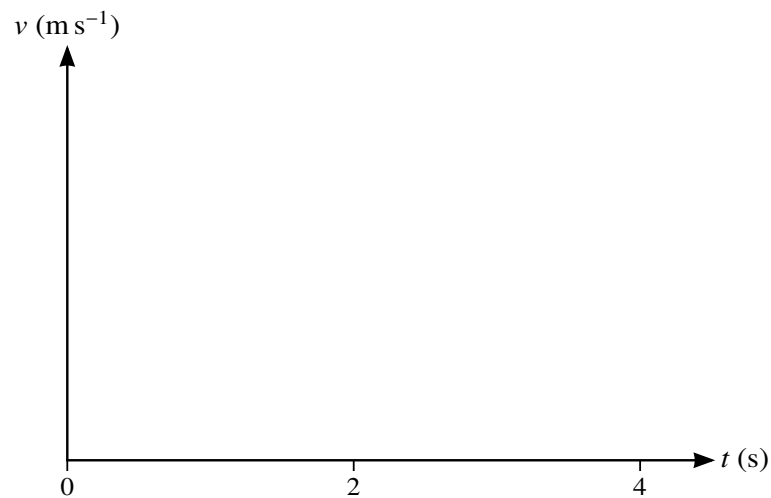

- (iv) Find the distance travelled by P in the interval $0 \leq t \leq 4$. [5]

56. [9709/w18/41/q7]

A particle moves in a straight line starting from rest from a point O . The acceleration of the particle at time t s after leaving O is $a \text{ m s}^{-2}$, where

$$a = 5.4 - 1.62t.$$

- (i) Find the positive value of t at which the velocity of the particle is zero, giving your answer as an exact fraction. [4]
- (ii) Find the velocity of the particle at $t = 10$ and sketch the velocity-time graph for the first ten seconds of the motion. [3]
- (iii) Find the total distance travelled during the first ten seconds of the motion. [5]

57. [9709/w18/42/q5]

A particle moves in a straight line starting from a point O with initial velocity 1 m s^{-1} . The acceleration of the particle at time t s after leaving O is $a \text{ m s}^{-2}$, where

$$a = 1.2t^{\frac{1}{2}} - 0.6t.$$

- (i) At time T s after leaving O the particle reaches its maximum velocity. Find the value of T . [2]
- (ii) Find the velocity of the particle when its acceleration is maximum (you do not need to verify that the acceleration is a maximum rather than a minimum). [6]

58. [9709/w18/43/q7]

A particle moves in a straight line. The particle is initially at rest at a point O on the line. At time t s after leaving O , the acceleration a m s⁻² of the particle is given by $a = 25 - t^2$ for $0 \leq t \leq 9$.

(i) Find the maximum velocity of the particle in this time period. [4]

(ii) Find the total distance travelled until the maximum velocity is reached. [2]

The acceleration of the particle for $t > 9$ is given by $a = -3t^{-\frac{1}{2}}$.

(iii) Find the velocity of the particle when $t = 25$. [4]

59. [9709/m17/42/q5]

A particle P moves in a straight line starting from a point O and comes to rest 35 s later. At time t s after leaving O , the velocity v m s⁻¹ of P is given by

$$\begin{aligned} v &= \frac{4}{5}t^2 & 0 \leq t \leq 5, \\ v &= 2t + 10 & 5 \leq t \leq 15, \\ v &= a + bt^2 & 15 \leq t \leq 35, \end{aligned}$$

where a and b are constants such that $a > 0$ and $b < 0$.

(i) Show that the values of a and b are 49 and -0.04 respectively. [3]

(ii) Sketch the velocity-time graph. [4]

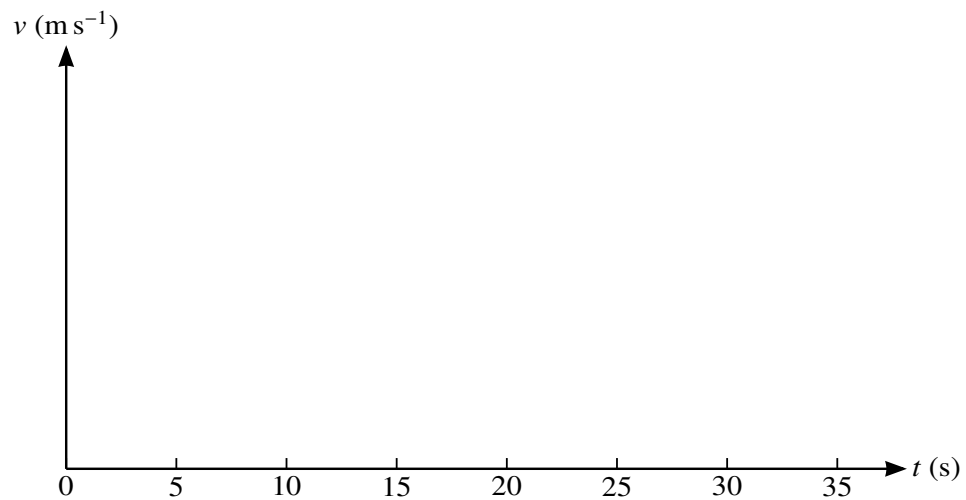

(iii) Find the total distance travelled by P during the 35 s. [5]

60. [9709/s17/41/q6]

A particle P moves in a straight line passing through a point O . At time t s, the velocity of P , v m s⁻¹, is given by $v = qt + rt^2$, where q and r are constants. The particle has velocity 4 m s⁻¹ when $t = 1$ and when $t = 2$.

- (i) Show that, when $t = 0.5$, the acceleration of P is 4 m s⁻². [4]
- (ii) Find the values of t when P is at instantaneous rest. [2]
- (iii) The particle is at O when $t = 3$. Find the distance of P from O when $t = 0$. [4]

61. [9709/s17/43/q4]

A particle P moves in a straight line starting from a point O . At time t s after leaving O , the velocity, v m s⁻¹, of P is given by $v = (2t - 5)^3$.

(i) Find the values of t when the acceleration of P is 54 m s⁻². [3]

(ii) Find an expression for the displacement of P from O at time t s. [3]

62. [9709/w17/41/q5]

A particle starts from a point O and moves in a straight line. The velocity of the particle at time t s after leaving O is v m s⁻¹, where

$$v = 1.5 + 0.4t \quad \text{for } 0 \leq t \leq 5,$$
$$v = \frac{100}{t^2} - 0.1t \quad \text{for } t \geq 5.$$

- (i) Find the acceleration of the particle during the first 5 seconds of motion. [1]
- (ii) Find the value of t when the particle is instantaneously at rest. [2]
- (iii) Find the total distance travelled by the particle in the first 10 seconds of motion. [5]

63. [9709/w17/42/q7]

A particle starts from rest and moves in a straight line. The velocity of the particle at time t s after the start is v m s⁻¹, where

$$v = -0.01t^3 + 0.22t^2 - 0.4t.$$

- (i) Find the two positive values of t for which the particle is instantaneously at rest. [2]
- (ii) Find the time at which the acceleration of the particle is greatest. [3]
- (iii) Find the distance travelled by the particle while its velocity is positive. [4]

64. [9709/w17/43/q5]

A particle starts from a fixed origin with velocity 0.4 m s^{-1} and moves in a straight line. The acceleration $a \text{ m s}^{-2}$ of the particle $t \text{ s}$ after it leaves the origin is given by $a = k(3t^2 - 12t + 2)$, where k is a constant. When $t = 1$, the velocity of P is 0.1 m s^{-1} .

- (i) Show that the value of k is 0.1. [5]
- (ii) Find an expression for the displacement of the particle from the origin in terms of t . [2]
- (iii) Hence verify that the particle is again at the origin at $t = 2$. [1]

65. [9709/m16/42/q7]

A particle P moves in a straight line. The velocity $v \text{ m s}^{-1}$ at time $t \text{ s}$ is given by

$$\begin{aligned}v &= 5t(t - 2) && \text{for } 0 \leq t \leq 4, \\v &= k && \text{for } 4 \leq t \leq 14, \\v &= 68 - 2t && \text{for } 14 \leq t \leq 20,\end{aligned}$$

where k is a constant.

- (i) Find k . [1]
- (ii) Sketch the velocity-time graph for $0 \leq t \leq 20$. [3]
- (iii) Find the set of values of t for which the acceleration of P is positive. [2]
- (iv) Find the total distance travelled by P in the interval $0 \leq t \leq 20$. [5]

66. [9709/s16/41/q6]

A particle P moves in a straight line. It starts at a point O on the line and at time t s after leaving O it has a velocity v m s⁻¹, where $v = 6t^2 - 30t + 24$.

- (i) Find the set of values of t for which the acceleration of the particle is negative. [2]
- (ii) Find the distance between the two positions at which P is at instantaneous rest. [4]
- (iii) Find the two positive values of t at which P passes through O . [3]

67. [9709/s16/42/q2]

A particle P moves in a straight line, starting from a point O . At time t s after leaving O , the velocity of P , $v \text{ m s}^{-1}$, is given by $v = 4t^2 - 8t + 3$.

(i) Find the two values of t at which P is at instantaneous rest. [2]

(ii) Find the distance travelled by P between these two times. [3]

68. [9709/s16/43/q7]

A particle P moves in a straight line. At time t s, the displacement of P from O is s m and the acceleration of P is a m s⁻², where $a = 6t - 2$. When $t = 1$, $s = 7$ and when $t = 3$, $s = 29$.

- (i) Find the set of values of t for which the particle is decelerating. [2]
- (ii) Find s in terms of t . [5]
- (iii) Find the time when the velocity of the particle is 10 m s⁻¹. [3]

69. [9709/w16/41/q7]

A racing car is moving in a straight line. The acceleration $a \text{ m s}^{-2}$ at time $t \text{ s}$ after the car starts from rest is given by

$$a = 15t - 3t^2 \quad \text{for } 0 \leq t \leq 5,$$
$$a = -\frac{625}{t^2} \quad \text{for } 5 < t \leq k,$$

where k is a constant.

- (i) Find the maximum acceleration of the car in the first five seconds of its motion. [3]
- (ii) Find the distance of the car from its starting point when $t = 5$. [3]
- (iii) The car comes to rest when $t = k$. Find the value of k . [5]

70. [9709/w16/42/q2]

A particle moves in a straight line. Its displacement t s after leaving a fixed point O on the line is s m, where $s = 2t^2 - \frac{80}{3}t^{\frac{3}{2}}$.

(i) Find the time at which the acceleration of the particle is zero. [4]

(ii) Find the displacement and velocity of the particle at this instant. [2]

71. [9709/w16/43/q5]

A particle P starts from a fixed point O and moves in a straight line. At time t s after leaving O , the velocity v m s⁻¹ of P is given by $v = 6t - 0.3t^2$. The particle comes to instantaneous rest at point X .

(i) Find the distance OX . [4]

A second particle Q starts from rest from O , at the same instant as P , and also travels in a straight line. The acceleration a m s⁻² of Q is given by $a = k - 12t$, where k is a constant. The displacement of Q from O is 400 m when $t = 10$.

(ii) Find the value of k . [4]

72. [9709/s15/41/q6]

Two particles A and B start to move at the same instant from a point O . The particles move in the same direction along the same straight line. The acceleration of A at time t s after starting to move is $a \text{ m s}^{-2}$, where $a = 0.05 - 0.0002t$.

(i) Find A 's velocity when $t = 200$ and when $t = 500$. [4]

B moves with constant acceleration for the first 200 s and has the same velocity as A when $t = 200$. B moves with constant retardation from $t = 200$ to $t = 500$ and has the same velocity as A when $t = 500$.

(ii) Find the distance between A and B when $t = 500$. [6]

73. [9709/s15/42/q1.1]

One end of a light inextensible string is attached to a block. The string makes an angle of 60° above the horizontal and is used to pull the block in a straight line on a horizontal floor with acceleration 0.5 m s^{-2} . The tension in the string is 8 N . The block starts to move with speed 0.3 m s^{-1} . For the first 5 s of the block's motion, find

(i) the distance travelled, [2]

(ii) the work done by the tension in the string. [2]

74. [9709/s15/42/q4]

A particle P moves in a straight line. At time t seconds after starting from rest at the point O on the line, the acceleration of P is $a \text{ m s}^{-2}$, where $a = 0.075t^2 - 1.5t + 5$.

(i) Find an expression for the displacement of P from O in terms of t . [4]

(ii) Hence find the time taken for P to return to the point O . [3]

75. [9709/s15/43/q7]

A particle P moves on a straight line. It starts at a point O on the line and returns to O 100 s later. The velocity of P is $v \text{ m s}^{-1}$ at time t s after leaving O , where

$$v = 0.0001t^3 - 0.015t^2 + 0.5t.$$

- (i) Show that P is instantaneously at rest when $t = 0$, $t = 50$ and $t = 100$. [2]
- (ii) Find the values of v at the times for which the acceleration of P is zero, and sketch the velocity-time graph for P 's motion for $0 \leq t \leq 100$. [7]
- (iii) Find the greatest distance of P from O for $0 \leq t \leq 100$. [4]

76. [9709/w15/41/q6]

A particle P moves in a straight line, starting from a point O . The velocity of P , measured in m s^{-1} , at time t s after leaving O is given by

$$v = 0.6t - 0.03t^2.$$

- (i) Verify that, when $t = 5$, the particle is 6.25 m from O . Find the acceleration of the particle at this time. [4]
- (ii) Find the values of t at which the particle is travelling at half of its maximum velocity. [6]

77. [9709/w15/42/q3]

A particle P moves along a straight line for 100 s. It starts at a point O and at time t seconds after leaving O the velocity of P is $v \text{ m s}^{-1}$, where

$$v = 0.000\,04t^3 - 0.006t^2 + 0.288t.$$

(i) Find the values of t at which the acceleration of P is zero. [3]

(ii) Find the displacement of P from O when $t = 100$. [3]

78. [9709/w15/43/q6]

A particle P starts from rest at a point O of a straight line and moves along the line. The displacement of the particle at time t s after leaving O is x m, where

$$x = 0.08t^2 - 0.0002t^3.$$

- (i) Find the value of t when P returns to O and find the speed of P as it passes through O on its return. [4]
- (ii) For the motion of P until the instant it returns to O , find
- (a) the total distance travelled, [3]
- (b) the average speed. [2]

Chapter 3

Uniformly accelerated motion

1. [9709/m25/42/q2]

A cyclist is travelling along a straight horizontal road at a speed of 4 m s^{-1} when she passes a point O . She accelerates at a constant rate for a distance of 42 m, reaching a speed of $V \text{ m s}^{-1}$. She maintains the speed of $V \text{ m s}^{-1}$ for 50 m and then decelerates at 2 m s^{-2} before coming to rest. The distance travelled while decelerating is 16 m.

(a) Find the value of V . [2]

(b) Find the total time for which she is in motion from the instant that she passes O . [3]

2. [9709/s25/45/q3]

A train travels 4.8 km between two stations, A and B . The train starts from rest at A and accelerates at a constant rate until it reaches a speed of 30 m s^{-1} . It then travels at this constant speed for T seconds, before decelerating at a constant rate, coming to rest at B . The total time for the journey is 180 s.

Find the value of T and hence find the distance moved by the train while travelling at the constant speed of 30 m s^{-1} . [5]

3. [9709/w25/42/q4]

A particle P of mass 0.1 kg is projected vertically upwards with speed 30 m s^{-1} from horizontal ground. At the same instant a particle Q of mass 0.4 kg is projected vertically upwards with speed 10 m s^{-1} from a height of 15 m above the ground. P and Q move in the same vertical line.

(a) Find the height above the ground at which P and Q collide. [4]

When P and Q collide, they coalesce.

(b) Find the speed of the combined particle at the instant that it reaches the ground. [5]

4. [9709/m24/42/q2]

A particle is projected vertically upwards from horizontal ground. The speed of the particle 2 seconds after it is projected is 5 m s^{-1} and it is travelling **downwards**.

- (a) Find the speed of projection of the particle. [2]
- (b) Find the distance travelled by the particle between the two times at which its speed is 10 m s^{-1} . [2]

5. [9709/s24/43/q3]

A car travels along a straight road with constant acceleration $a \text{ m s}^{-2}$, where $a > 0$. The car passes through points A , B and C in that order. The speed of the car at A is $u \text{ m s}^{-1}$ in the direction AB . The distance BC is twice the distance AB . The car takes 8 seconds to travel from A to B and 10 seconds to travel from B to C .

(a) Find u in terms of a . [4]

(b) Find the speed of the car at C in terms of a . [2]

6. [9709/w24/41/q5]

A particle, A , is projected vertically upwards from a point O with a speed of 80 m s^{-1} . One second later a second particle, B , with the same mass as A , is projected vertically upwards from O with a speed of 100 m s^{-1} . At time T s after the first particle is projected, the two particles collide and coalesce to form a particle C .

- (a) Show that $T = 3.5$. [4]
- (b) Find the height above O at which the particles collide. [1]
- (c) Find the time from A being projected until C returns to O . [5]

7. [9709/m23/42/q2]

A particle P is projected vertically upwards from horizontal ground with speed 15 m s^{-1} .

(a) Find the speed of P when it is 10 m above the ground. [2]

At the same instant that P is projected, a second particle Q is dropped from a height of 18 m above the ground in the same vertical line as P .

(b) Find the height above the ground at which the two particles collide. [3]

8. [9709/s23/41/q2]

A particle P of mass 0.4 kg is projected vertically upwards from horizontal ground with speed 10 m s^{-1} .

(a) Find the greatest height above the ground reached by P . [2]

When P reaches the ground again, it bounces vertically upwards. At the first instant that it hits the ground, P loses 7.2 J of energy.

(b) Find the time between the first and second instants at which P hits the ground. [4]

9. [9709/s23/43/q6]

An elevator is pulled vertically upwards by a cable. The elevator accelerates at 0.4 m s^{-2} for 5 s, then travels at constant speed for 25 s. The elevator then decelerates at 0.2 m s^{-2} until it comes to rest.

(a) Find the greatest speed of the elevator and hence draw a velocity-time graph for the motion of the elevator. [3]

(b) Find the total distance travelled by the elevator. [2]

The mass of the elevator is 1200 kg and there is a crate of mass m kg resting on the floor of the elevator.

(c) Given that the tension in the cable when the elevator is decelerating is 12 250 N, find the value of m . [3]

(d) Find the greatest magnitude of the force exerted on the crate by the floor of the elevator, and state its direction. [3]

10. [9709/w23/42/q5]

A particle A of mass 0.5 kg is projected vertically upwards from horizontal ground with speed 25 m s^{-1} .

- (a) Find the speed of A when it reaches a height of 20 m above the ground. [2]

When A reaches a height of 20 m , it collides with a particle B of mass 0.3 kg which is moving downwards in the same vertical line as A with speed 32.5 m s^{-1} . In the collision between the two particles, B is brought to instantaneous rest.

- (b) Show that the velocity of A immediately after the collision is 4.5 m s^{-1} downwards. [2]

- (c) Find the time interval between A and B reaching the ground. You should assume that A does not bounce when it reaches the ground. [4]

11. [9709/w23/43/q1]

A particle is projected vertically upwards from horizontal ground with a speed of $u \text{ m s}^{-1}$. The particle has height $s \text{ m}$ above the ground at times 3 seconds and 4 seconds after projection.

Find the value of u and the value of s .

[3]

12. [9709/m22/42/q2]

A particle P is projected vertically upwards from horizontal ground with speed $u \text{ m s}^{-1}$. P reaches a maximum height of 20 m above the ground.

(a) Find the value of u . [2]

(b) Find the total time for which P is at least 15 m above the ground. [3]

13. [9709/s22/43/q2]

A particle P is projected vertically upwards from horizontal ground. P reaches a maximum height of 45 m. After reaching the ground, P comes to rest without rebounding.

(a) Find the speed at which P was projected. [2]

(b) Find the total time for which the speed of P is at least 10 m s^{-1} . [3]

14. [9709/w22/41/q4]

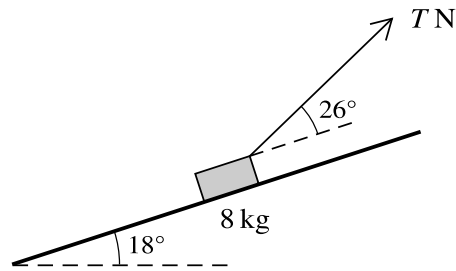

A block of mass 8 kg is placed on a rough plane which is inclined at an angle of 18° to the horizontal. The block is pulled up the plane by a light string that makes an angle of 26° above a line of greatest slope. The tension in the string is T N (see diagram). The coefficient of friction between the block and plane is 0.65.

(a) The acceleration of the block is 0.2 m s^{-2} .

Find T .

[7]

(b) The block is initially at rest.

Find the distance travelled by the block during the fourth second of motion.

[2]

15. [9709/w22/42/q2]

A particle P of mass 0.4 kg is in limiting equilibrium on a plane inclined at 30° to the horizontal.

(a) Show that the coefficient of friction between the particle and the plane is $\frac{1}{3}\sqrt{3}$. [3]

A force of magnitude 7.2 N is now applied to P directly up a line of greatest slope of the plane.

(b) Given that P starts from rest, find the time that it takes for P to move 1 m up the plane. [4]

16. [9709/w22/43/q1]

A particle P is projected vertically upwards with speed $u \text{ m s}^{-1}$ from a point on the ground. P reaches its greatest height after 3 s.

(a) Find u . [1]

(b) Find the greatest height of P above the ground. [2]

17. [9709/w22/43/q4]

A particle P travels in the positive direction along a straight line with constant acceleration. P travels a distance of 52 m during the 2nd second of its motion and a distance of 64 m during the 4th second of its motion.

(a) Find the initial speed and the acceleration of P . [5]

(b) Find the distance travelled by P during the first 10 seconds of its motion. [2]

18. [9709/s21/41/q4]

Two cyclists, Isabella and Maria, are having a race. They both travel along a straight road with constant acceleration, starting from rest at point A.

Isabella accelerates for 5 s at a constant rate $a \text{ m s}^{-2}$. She then travels at the constant speed she has reached for 10 s, before decelerating to rest at a constant rate over a period of 5 s.

Maria accelerates at a constant rate, reaching a speed of 5 m s^{-1} in a distance of 27.5 m. She then maintains this speed for a period of 10 s, before decelerating to rest at a constant rate over a period of 5 s.

(a) Given that $a = 1.1$, find which cyclist travels further. [5]

(b) Find the value of a for which the two cyclists travel the same distance. [2]

19. [9709/s21/42/q3]

A ring of mass 0.3 kg is threaded on a horizontal rough rod. The coefficient of friction between the ring and the rod is 0.8. A force of magnitude 8 N acts on the ring. This force acts at an angle of 10° above the horizontal in the vertical plane containing the rod.

Find the time taken for the ring to move, from rest, 0.6 m along the rod.

[6]

20. [9709/s21/43/q4]

A particle is projected vertically upwards with speed $u \text{ m s}^{-1}$ from a point on horizontal ground. After 2 seconds, the height of the particle above the ground is 24 m.

(a) Show that $u = 22$. [2]

(b) The height of the particle above the ground is more than h m for a period of 3.6 s.

Find h . [4]

21. [9709/w21/41/q1]

A bus moves from rest with constant acceleration for 12 s. It then moves with constant speed for 30 s before decelerating uniformly to rest in a further 6 s. The total distance travelled is 585 m.

- (a) Find the constant speed of the bus. [2]
- (b) Find the magnitude of the deceleration. [1]

22. [9709/m20/42/q4]

A cyclist travels along a straight road with constant acceleration. He passes through points A , B and C . The cyclist takes 2 seconds to travel along each of the sections AB and BC and passes through B with speed 4.5 m s^{-1} . The distance AB is $\frac{4}{5}$ of the distance BC .

- (a) Find the acceleration of the cyclist. [5]
- (b) Find AC . [2]

23. [9709/s20/41/q3]

A particle P is projected vertically upwards with speed 5 m s^{-1} from a point A which is 2.8 m above horizontal ground.

(a) Find the greatest height above the ground reached by P . [3]

(b) Find the length of time for which P is at a height of more than 3.6 m above the ground. [4]

24. [9709/s20/43/q4]

A car starts from rest and moves in a straight line with constant acceleration $a \text{ m s}^{-2}$ for a distance of 50 m. The car then travels with constant velocity for 500 m for a period of 25 s, before decelerating to rest. The magnitude of this deceleration is $2a \text{ m s}^{-2}$.

- (a) Sketch the velocity-time graph for the motion of the car. [1]



- (b) Find the value of a . [3]
(c) Find the total time for which the car is in motion. [3]

25. [9709/w20/42/q5]

A particle is projected vertically upwards with speed 40 m s^{-1} alongside a building of height $h \text{ m}$.

(a) Given that the particle is above the level of the top of the building for 4 s, find h . [4]

(b) One second after the first particle is projected, a second particle is projected vertically upwards from the top of the building with speed 20 m s^{-1} .

Denoting the time after projection of the first particle by $t \text{ s}$, find the value of t for which the two particles are at the same height above the ground. [4]

26. [9709/w20/43/q1]

A particle P is projected vertically upwards with speed $v \text{ m s}^{-1}$ from a point on the ground. P reaches its greatest height after 3 s.

(a) Find v . [1]

(b) Find the greatest height of P above the ground. [2]

27. [9709/m19/42/q2]

A particle is projected vertically upwards with speed 30 m s^{-1} from a point on horizontal ground.

- (i) Show that the maximum height above the ground reached by the particle is 45 m. [2]
- (ii) Find the time that it takes for the particle to reach a height of 33.75 m above the ground for the first time. Find also the speed of the particle at this time. [4]

28. [9709/s19/41/q2]

A particle P is projected vertically upwards with speed 25 m s^{-1} from a point 3 m above horizontal ground.

- (i) Find the time taken for P to reach its greatest height. [2]
- (ii) Find the length of time for which P is higher than 23 m above the ground. [3]
- (iii) P is higher than h m above the ground for 1 second. Find h . [2]

29. [9709/s19/42/q2]

A car moves in a straight line with initial speed $u \text{ m s}^{-1}$ and constant acceleration $a \text{ m s}^{-2}$. The car takes 5 s to travel the first 80 m and it takes 8 s to travel the first 160 m. Find a and u . [6]

30. [9709/s19/42/q4]

A constant resistance to motion of magnitude 350 N acts on a car of mass 1250 kg. The engine of the car exerts a constant driving force of 1200 N. The car travels along a road inclined at an angle of θ to the horizontal, where $\sin \theta = 0.05$. Find the speed of the car when it has moved 100 m from rest in each of the following cases.

- The car is moving up the hill.
- The car is moving down the hill.

[7]

31. [9709/w19/41/q6]

A particle of mass 0.4 kg is released from rest at a height of 1.8 m above the surface of the water in a tank. There is no instantaneous change of speed when the particle enters the water. The water exerts an upward force of 5.6 N on the particle when it is in the water.

- (i) Find the velocity of the particle at the instant when it reaches the surface of the water. [2]
- (ii) Find the time that it takes from the instant when the particle enters the water until it comes to instantaneous rest in the water. You may assume that the tank is deep enough so that the particle does not reach the bottom of the tank. [4]
- (iii) Sketch a velocity-time graph for the motion of the particle from the instant at which it is released until it comes to instantaneous rest in the water. [3]

32. [9709/w19/42/q5]

Two particles A and B move in the same vertical line. Particle A is projected vertically upwards from the ground with speed 20 m s^{-1} . One second later particle B is dropped from rest from a height of 40 m .

(i) Find the height above the ground at which the two particles collide. [4]

(ii) Find the difference in the speeds of the two particles at the instant when the collision occurs. [3]

33. [9709/w19/43/q4]

A car travels along a straight road with constant acceleration. It passes through points P , Q , R and S . The times taken for the car to travel from P to Q , Q to R and R to S are each equal to 10 s. The distance QR is 1.5 times the distance PQ . At point Q the speed of the car is 20 m s^{-1} .

(i) Show that the acceleration of the car is 0.8 m s^{-2} . [3]

(ii) Find the distance QS and hence find the average speed of the car between Q and S . [3]

34. [9709/m18/42/q1]

Two particles A and B , of masses 0.8 kg and 0.2 kg respectively, are connected by a light inextensible string that passes over a fixed smooth pulley. The particles hang vertically. The system is released from rest. Show that the acceleration of A has magnitude 6 m s^{-2} and find the tension in the string.

[4]

35. [9709/m18/42/q5]

A small rocket is fired vertically upwards, starting from rest at ground level, and moves with constant acceleration. The rocket reaches a height of 200 m after 10 s.

- (i) Show that the speed of the rocket after 10 s is 40 m s^{-1} and find the acceleration of the rocket during the first 10 s. [4]
- (ii) After 10 s, the rocket's fuel stops burning and there is no upward force acting on the rocket. Find the maximum height above ground level reached by the rocket. [2]
- (iii) Find the total time from the instant the rocket is fired until it returns to the ground. [4]

36. [9709/s18/41/q1]

A particle P is projected vertically upwards with speed 24 m s^{-1} from a point 5 m above ground level. Find the time from projection until P reaches the ground. [3]

37. [9709/s18/41/q3]

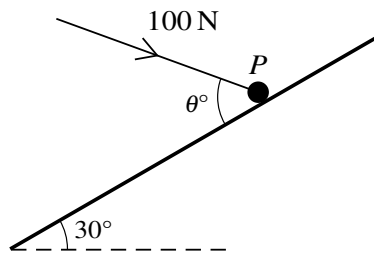

A particle P of mass 8 kg is on a smooth plane inclined at an angle of 30° to the horizontal. A force of magnitude 100 N , making an angle of θ° with a line of greatest slope and lying in the vertical plane containing the line of greatest slope, acts on P (see diagram).

- (i) Given that P is in equilibrium, show that $\theta = 66.4$, correct to 1 decimal place, and find the normal reaction between the plane and P . [4]
- (ii) Given instead that $\theta = 30$, find the acceleration of P . [2]

38. [9709/s18/42/q4]

A particle P moves in a straight line $ABCD$ with constant acceleration. The distances AB and BC are 100 m and 148 m respectively. The particle takes 4 s to travel from A to B and also takes 4 s to travel from B to C .

(i) Show that the acceleration of P is 3 m s^{-2} and find the speed of P at A . [6]

(ii) P reaches D with a speed of 61 m s^{-1} . Find the distance CD . [3]

39. [9709/s18/43/q2]

A small ball is projected vertically downwards with speed 5 m s^{-1} from a point A at a height of 7.2 m above horizontal ground. The ball hits the ground with speed $V \text{ m s}^{-1}$ and rebounds vertically upwards with speed $\frac{1}{2}V \text{ m s}^{-1}$. The highest point the ball reaches after rebounding is B . Find V and hence find the total time taken for the ball to reach the ground from A and rebound to B . [5]

40. [9709/w18/41/q1]

A particle of mass 0.2 kg moving in a straight line experiences a constant resistance force of 1.5 N . When the particle is moving at speed 2.5 m s^{-1} , a constant force of magnitude $F \text{ N}$ is applied to it in the direction in which it is moving. Given that the speed of the particle 5 seconds later is 4.5 m s^{-1} , find the value of F . [4]

41. [9709/w18/41/q6]

A particle is projected from a point P with initial speed $u \text{ m s}^{-1}$ up a line of greatest slope PQR of a rough inclined plane. The distances PQ and QR are both equal to 0.8 m. The particle takes 0.6 s to travel from P to Q and 1 s to travel from Q to R .

- (i) Show that the deceleration of the particle is $\frac{2}{3} \text{ m s}^{-2}$ and hence find u , giving your answer as an exact fraction. [6]
- (ii) Given that the plane is inclined at 3° to the horizontal, find the value of the coefficient of friction between the particle and the plane. [4]

42. [9709/s17/41/q2]

A particle of mass 0.8 kg is projected with a speed of 12 m s^{-1} up a line of greatest slope of a rough plane inclined at an angle of 10° to the horizontal. The coefficient of friction between the particle and the plane is 0.4 .

(i) Find the acceleration of the particle. [4]

(ii) Find the distance the particle moves up the plane before coming to rest. [2]

43. [9709/s17/41/q5]

A particle P moves in a straight line $ABCD$ with constant deceleration. The velocities of P at A , B and C are 20 m s^{-1} , 12 m s^{-1} and 6 m s^{-1} respectively.

(i) Find the ratio of distances $AB : BC$. [4]

(ii) The particle comes to rest at D . Given that the distance AD is 80 m, find the distance BC . [3]

44. [9709/s17/42/q3]

A particle A moves in a straight line with constant speed 10 m s^{-1} . Two seconds after A passes a point O on the line, a particle B passes through O , moving along the line in the same direction as A . Particle B has speed 16 m s^{-1} at O and has a constant deceleration of 2 m s^{-2} .

- (i) Find expressions, in terms of t , for the displacement from O of each particle t s after B passes through O . [3]
- (ii) Find the distance between the particles when B comes to instantaneous rest. [3]
- (iii) Find the minimum distance between the particles. [3]

45. [9709/s17/43/q5]

A particle is projected vertically upwards from a point O with a speed of 12 m s^{-1} . Two seconds later a second particle is projected vertically upwards from O with a speed of 20 m s^{-1} . At time $t \text{ s}$ after the second particle is projected, the two particles collide.

(i) Find t . [5]

(ii) Hence find the height above O at which the particles collide. [1]

46. [9709/w17/41/q1]

A block of mass 3 kg is initially at rest on a smooth horizontal floor. A force of 12 N, acting at an angle of 25° above the horizontal, is applied to the block. Find the distance travelled by the block in the first 5 seconds of its motion. [4]

47. [9709/w17/42/q3]

A car travels along a straight road with constant acceleration. It passes through points A , B and C . The car passes point A with velocity 14 m s^{-1} . The two sections AB and BC are of equal length. The times taken to travel along AB and BC are 5 s and 3 s respectively.

- (i) Write down an expression for the distance AB in terms of the acceleration of the car. Write down a similar expression for the distance AC . Hence show that the acceleration of the car is 4 m s^{-2} . [4]
- (ii) Find the speed of the car as it passes point C . [2]

48. [9709/w17/42/q4]

A particle P is projected vertically upwards from horizontal ground with speed 12 m s^{-1} .

(i) Find the time taken for P to return to the ground. [2]

The time in seconds after P is projected is denoted by t . When $t = 1$, a second particle Q is projected vertically upwards with speed 10 m s^{-1} from a point which is 5 m above the ground. Particles P and Q move in different vertical lines.

(ii) Find the set of values of t for which the two particles are moving in the same direction. [4]

49. [9709/w17/43/q3]

A particle is released from rest and slides down a line of greatest slope of a rough plane which is inclined at 25° to the horizontal. The coefficient of friction between the particle and the plane is 0.4.

(i) Find the acceleration of the particle. [4]

(ii) Find the distance travelled by the particle in the first 3 s after it is released. [2]

50. [9709/m16/42/q1]

A cyclist has mass 85 kg and rides a bicycle of mass 20 kg. The cyclist rides along a horizontal road against a total resistance force of 40 N. Find the total work done by the cyclist in increasing his speed from 5 m s^{-1} to 10 m s^{-1} while travelling a distance of 50 m. [3]

51. [9709/s16/43/q2]

Alan starts walking from a point O , at a constant speed of 4 m s^{-1} , along a horizontal path. Ben walks along the same path, also starting from O . Ben starts from rest 5 s after Alan and accelerates at 1.2 m s^{-2} for 5 s. Ben then continues to walk at a constant speed until he is at the same point, P , as Alan.

- (i) Find how far Ben has travelled when he has been walking for 5 s and find his speed at this instant. [2]
- (ii) Find the distance OP . [3]

52. [9709/w16/41/q3]

A particle P is projected vertically upwards from a point O . When the particle is at a height of 0.5 m, its speed is 6 m s^{-1} . Find

- (i) the greatest height reached by the particle above O , [3]
- (ii) the time after projection at which the particle returns to O . [3]

53. [9709/w16/42/q7]

A car starts from rest and moves in a straight line from point A with constant acceleration 3 m s^{-2} for 10 s. The car then travels at constant speed for 30 s before decelerating uniformly, coming to rest at point B . The distance AB is 1.5 km.

- (i) Find the total distance travelled in the first 40 s of motion. [3]

When the car has been moving for 20 s, a motorcycle starts from rest and accelerates uniformly in a straight line from point A to a speed $V \text{ m s}^{-1}$. It then maintains this speed for 30 s before decelerating uniformly to rest at point B . The motorcycle comes to rest at the same time as the car.

- (ii) Given that the magnitude of the acceleration $a \text{ m s}^{-2}$ of the motorcycle is three times the magnitude of its deceleration, find the value of a . [6]

- (iii) Sketch the displacement-time graph for the motion of the car. [3]

54. [9709/w16/43/q4]

A ball A is released from rest at the top of a tall tower. One second later, another ball B is projected vertically upwards from ground level near the bottom of the tower with a speed of 20 m s^{-1} . The two balls are at the same height 1.5 s after ball B is projected.

(i) Show that the height of the tower is 50 m. [3]

(ii) Find the length of time for which ball B has been in motion when ball A reaches the ground. Hence find the total distance travelled by ball B up to the instant when ball A reaches the ground. [5]

55. [9709/s15/41/q3]

A block of weight 6.1 N slides down a slope inclined at $\tan^{-1}\left(\frac{11}{60}\right)$ to the horizontal. The coefficient of friction between the block and the slope is $\frac{1}{4}$. The block passes through a point A with speed 2 m s^{-1} . Find how far the block moves from A before it comes to rest. [5]

56. [9709/s15/42/q5]

A particle P starts from rest at a point O on a horizontal straight line. P moves along the line with constant acceleration and reaches a point A on the line with a speed of 30 m s^{-1} . At the instant that P leaves O , a particle Q is projected vertically upwards from the point A with a speed of 20 m s^{-1} . Subsequently P and Q collide at A . Find

(i) the acceleration of P , [4]

(ii) the distance OA . [2]

57. [9709/s15/43/q4]

A lorry of mass 12 000 kg moves up a straight hill of length 500 m, starting at the bottom with a speed of 24 m s^{-1} and reaching the top with a speed of 16 m s^{-1} . The top of the hill is 25 m above the level of the bottom of the hill. The resistance to motion of the lorry is 7500 N. Find the driving force of the lorry. [6]

58. [9709/w15/41/q2]

A particle of mass 0.5 kg starts from rest and slides down a line of greatest slope of a smooth plane. The plane is inclined at an angle of 30° to the horizontal.

- (i) Find the time taken for the particle to reach a speed of 2.5 m s^{-1} . [3]

When the particle has travelled 3 m down the slope from its starting point, it reaches rough horizontal ground at the bottom of the slope. The frictional force acting on the particle is 1 N.

- (ii) Find the distance that the particle travels along the ground before it comes to rest. [3]

59. [9709/w15/41/q7]

A cyclist starts from rest at point A and moves in a straight line with acceleration 0.5 m s^{-2} for a distance of 36 m. The cyclist then travels at constant speed for 25 s before slowing down, with constant deceleration, to come to rest at point B . The distance AB is 210 m.

(i) Find the total time that the cyclist takes to travel from A to B . [5]

24 s after the cyclist leaves point A , a car starts from rest from point A , with constant acceleration 4 m s^{-2} , towards B . It is given that the car overtakes the cyclist while the cyclist is moving with constant speed.

(ii) Find the time that it takes from when the cyclist starts until the car overtakes her. [5]

60. [9709/w15/42/q2]

A particle is released from rest at a point H m above horizontal ground and falls vertically. The particle passes through a point 35 m above the ground with a speed of $(V - 10)$ m s⁻¹ and reaches the ground with a speed of V m s⁻¹. Find

- (i) the value of V , [3]
- (ii) the value of H . [2]

Chapter 4

Resolving forces in two dimensions

1. [9709/m25/42/q1]

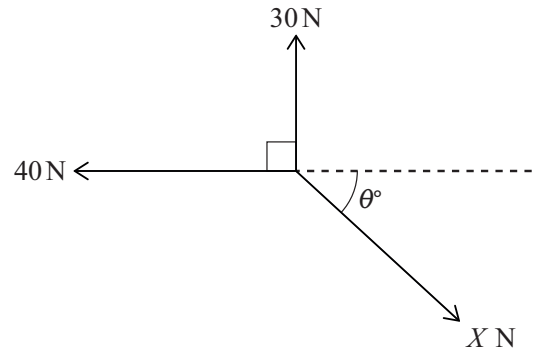

Three coplanar forces of magnitudes 40 N, 30 N and X N act at a point in the directions shown in the diagram.

Given that the forces are in equilibrium, find the values of θ and X .

[4]

2. [9709/s25/41/q2]

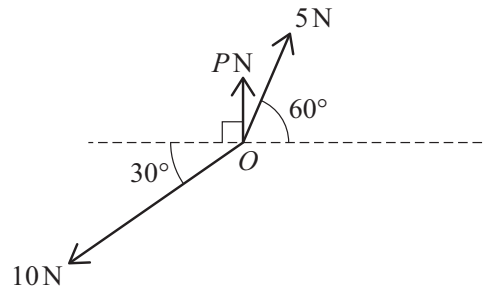

Three coplanar forces of magnitudes PN , 5 N and 10 N act at a point O , as shown in the diagram. The resultant of the three forces has magnitude QN and acts in a direction perpendicular to the force of magnitude PN .

Find the value of P and the value of Q .

[4]

3. [9709/s25/42/q3]

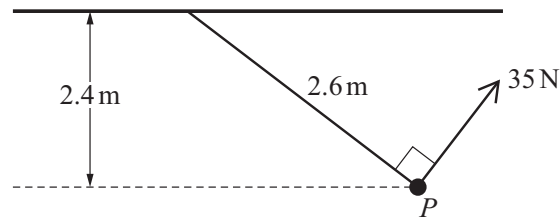

A particle P of mass m kg is attached to one end of a light inextensible string of length 2.6 m. The other end of the string is attached to a fixed point on a horizontal ceiling, and the string is taut. The particle is held in equilibrium by a force of magnitude 35 N, acting in a vertical plane which is perpendicular to the ceiling and contains the string. The force acts in a direction perpendicular to the string (see diagram). The tension in the string is T N and the vertical distance of P from the ceiling is 2.4 m.

Find, in either order, the value of m and the value of T .

[4]

4. [9709/s25/45/q4]

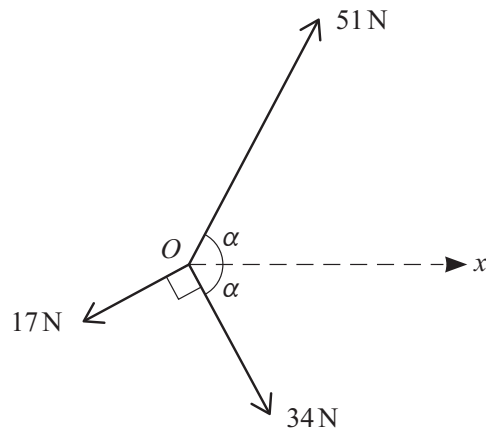

Coplanar forces of magnitudes 17 N, 51 N and 34 N act at a point O in the directions shown in the diagram, where $\tan \alpha = \frac{15}{8}$.

(a) Find the magnitude and direction of the resultant of the three forces. [6]

The force of magnitude 51 N is replaced by a force of magnitude P N acting in the same direction. The resultant of the three forces now acts in the positive x -direction.

(b) Find the value of P . [2]

5. [9709/w25/41/q3]

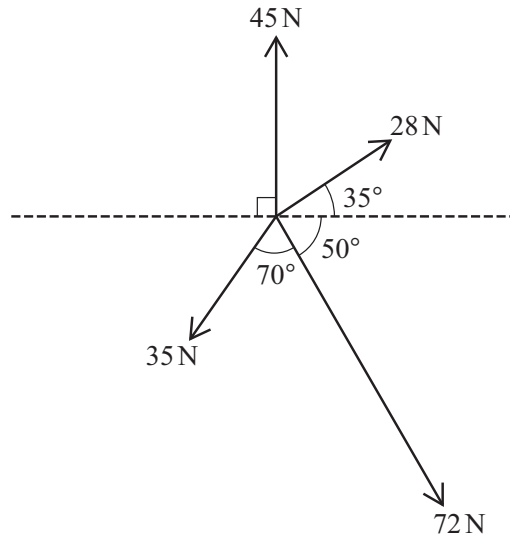

Coplanar forces of magnitudes 45 N, 28 N, 72 N and 35 N act at a point in the directions shown in the diagram.

Find, in either order, the magnitude and direction of the resultant force.

[6]

6. [9709/w25/42/q7]

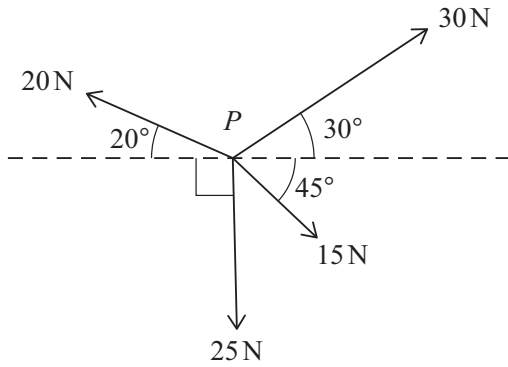

Fig. 7.1

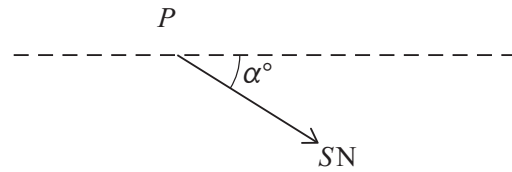

Fig. 7.2

Four coplanar forces of magnitudes 20 N, 30 N, 15 N and 25 N act at a point P in the directions shown in Fig. 7.1. The forces act in a vertical plane. The resultant of these forces has magnitude SN and acts at an angle α° below the horizontal as shown in Fig. 7.2.

(a) Find the value of S and the value of α . [6]

A small ring of mass 0.6 kg is threaded on a rough straight horizontal wire. The four forces shown in Fig. 7.1 act on the ring and are in the same vertical plane as the wire. The ring starts from rest and takes 3 s to travel a distance of 2 m along the wire.

(b) Find the coefficient of friction between the ring and the wire. [5]

7. [9709/w25/45/q1]

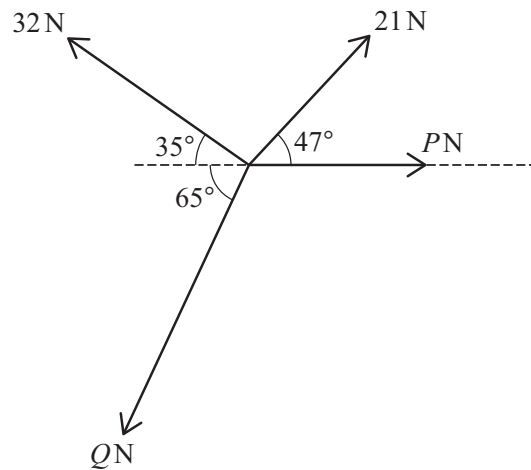

Coplanar forces of magnitudes PN , QN , $32N$ and $21N$ act at a point in the directions shown in the diagram. The forces are in equilibrium.

Find the value of P and the value of Q .

[5]

8. [9709/m24/42/q4]

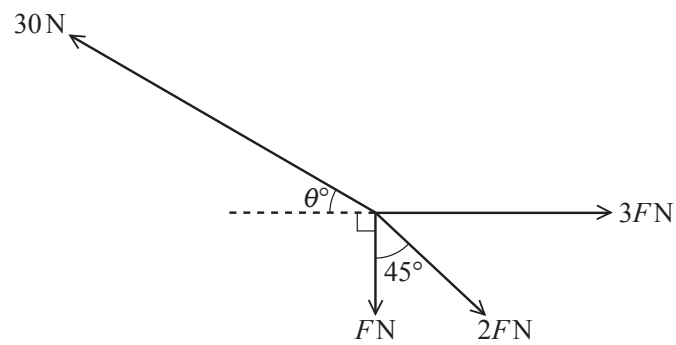

Four coplanar forces act at a point. The magnitudes of the forces are $F\text{N}$, $2F\text{N}$, $3F\text{N}$ and 30N . The directions of the forces are as shown in the diagram.

Given that the forces are in equilibrium, find the value of F and the value of θ .

[6]

9. [9709/s24/41/q2]

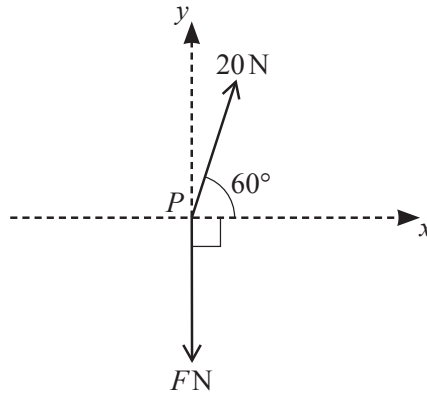

Two forces of magnitudes 20 N and FN act at a point P in the directions shown in the diagram.

- (a) Given that the resultant force has no component in the y -direction, calculate the value of F . [2]
- (b) Given instead that $F = 10$, find the magnitude and direction of the resultant force. [5]

10. [9709/s24/42/q3]

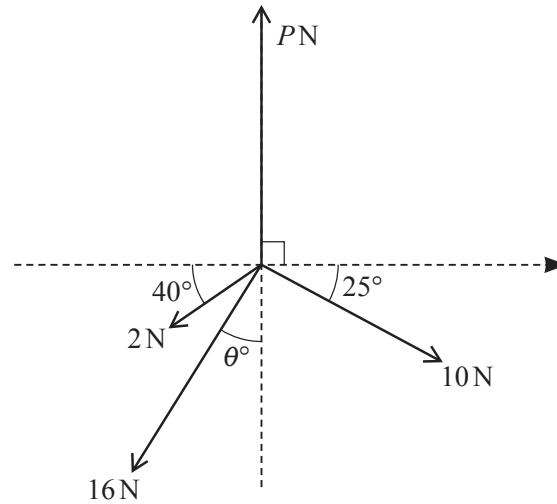

Four coplanar forces of magnitude P N, 10 N, 16 N and 2 N act at a point in the directions shown in the diagram. It is given that the forces are in equilibrium.

Find the values of θ and P .

[6]

11. [9709/s24/43/q2]

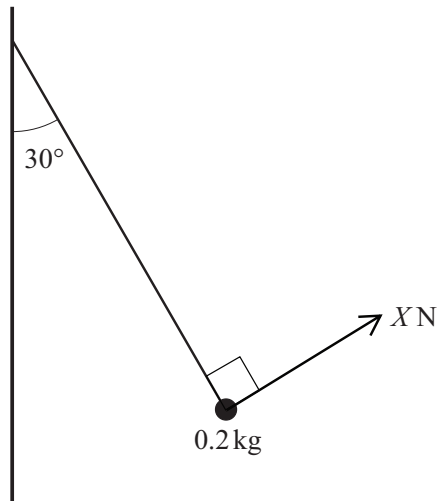

A particle of mass 0.2 kg is attached to one end of a light inextensible string. The other end of the string is attached to a fixed point on a vertical wall. The particle is held in equilibrium by a force of magnitude $X \text{ N}$, perpendicular to the string, with the string taut and making an angle of 30° with the wall (see diagram).

Find the tension in the string and the value of X .

[3]

12. [9709/w24/41/q3]

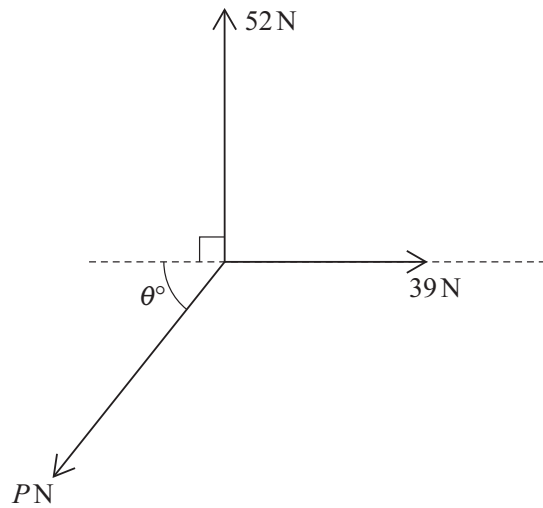

Coplanar forces of magnitudes 52 N, 39 N and P N act at a point in the directions shown in the diagram. The system is in equilibrium.

Find the values of P and θ .

[4]

13. [9709/w24/42/q4]

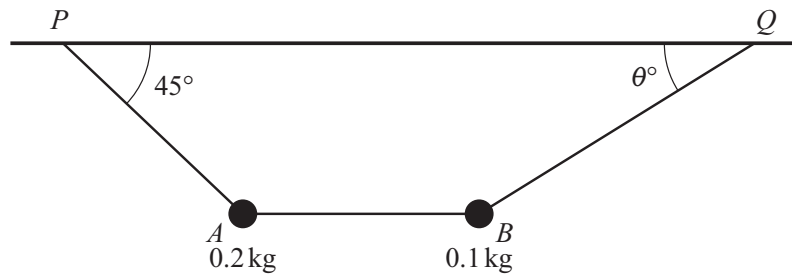

The diagram shows two particles, A and B , of masses 0.2 kg and 0.1 kg respectively. The particles are suspended below a horizontal ceiling by two strings, AP and BQ , attached to fixed points P and Q on the ceiling. The particles are connected by a horizontal string, AB . Angle $APQ = 45^\circ$ and $BQP = \theta^\circ$. Each string is light and inextensible. The particles are in equilibrium.

- (a) Find the value of the tension in the string AB . [2]
- (b) Find the value of θ and the tension in the string BQ . [4]

14. [9709/w24/43/q2]

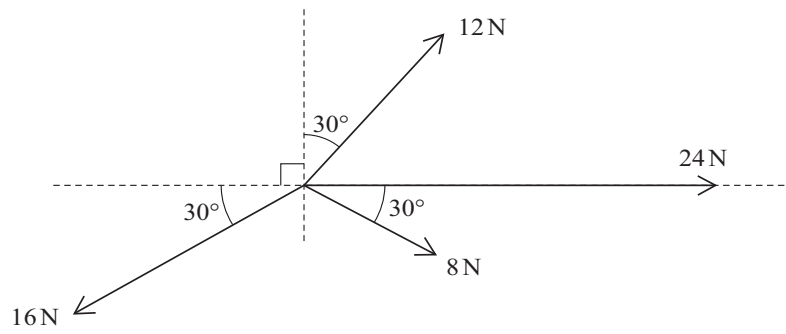

Coplanar forces of magnitudes 16 N, 12 N, 24 N and 8 N act at a point in the directions shown in the diagram.

Find the magnitude and direction of the single additional force acting at the same point which will produce equilibrium. [6]

15. [9709/m23/42/q5]

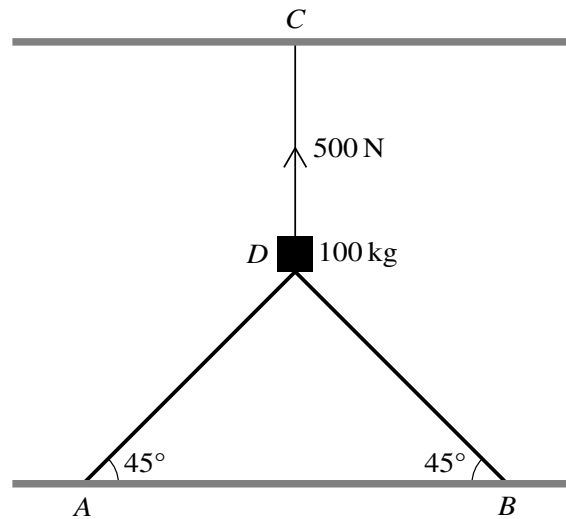

The diagram shows a block D of mass 100 kg supported by two sloping struts AD and BD , each attached at an angle of 45° to fixed points A and B respectively on a horizontal floor. The block is also held in place by a vertical rope CD attached to a fixed point C on a horizontal ceiling. The tension in the rope CD is 500 N and the block rests in equilibrium.

(a) Find the magnitude of the force in each of the struts AD and BD . [3]

A horizontal force of magnitude $F\text{ N}$ is applied to the block in a direction parallel to AB .

(b) Find the value of F for which the magnitude of the force in the strut AD is zero. [3]

16. [9709/s23/41/q5]

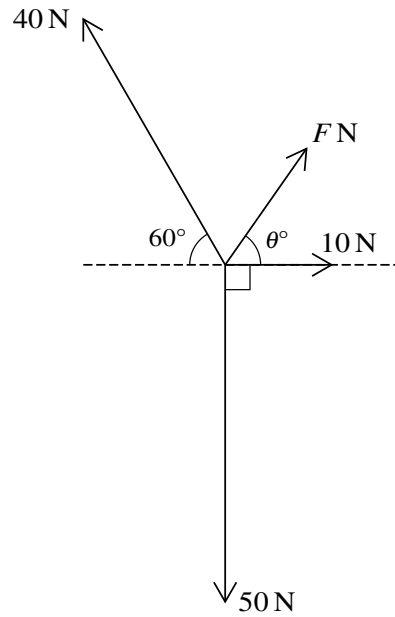

Four coplanar forces act at a point. The magnitudes of the forces are F N, 10 N, 50 N and 40 N. The directions of the forces are as shown in the diagram.

- (a) Given that the forces are in equilibrium, find the value of F and the value of θ . [6]
- (b) Given instead that $F = 10\sqrt{2}$ and $\theta = 45$, find the direction and the exact magnitude the resultant force. [3]

17. [9709/s23/42/q3]

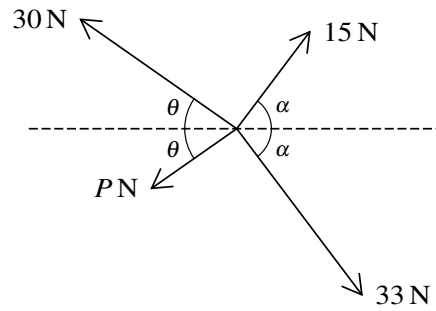

Coplanar forces of magnitudes 30 N, 15 N, 33 N and P N act at a point in the directions shown in the diagram, where $\tan \alpha = \frac{4}{3}$. The system is in equilibrium.

- (a) Show that $\left(\frac{14.4}{30-P}\right)^2 + \left(\frac{28.8}{P+30}\right)^2 = 1$. [4]
- (b) Verify that $P = 6$ satisfies this equation and find the value of θ . [2]

18. [9709/s23/43/q3]

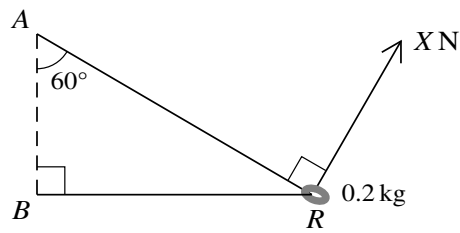

A smooth ring R of mass 0.2 kg is threaded on a light string ARB . The ends of the string are attached to fixed points A and B with A vertically above B . The string is taut and angle $ABR = 90^\circ$. The angle between the part AR of the string and the vertical is 60° . The ring is held in equilibrium by a force of magnitude $X \text{ N}$, acting on the ring in a direction perpendicular to AR (see diagram).

Calculate the tension in the string and the value of X .

[5]

19. [9709/w23/41/q2]

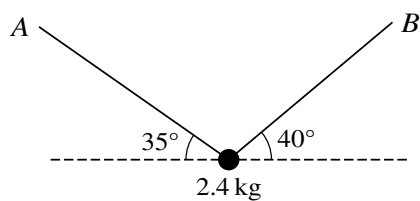

A particle of mass 2.4 kg is held in equilibrium by two light inextensible strings, one of which is attached to point A and the other attached to point B . The strings make angles of 35° and 40° with the horizontal (see diagram).

Find the tension in each of the two strings.

[5]

20. [9709/w23/42/q2]

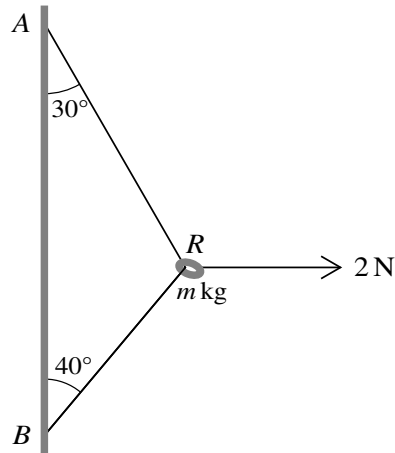

The diagram shows a smooth ring R , of mass m kg, threaded on a light inextensible string. A horizontal force of magnitude 2 N acts on R . The ends of the string are attached to fixed points A and B on a vertical wall. The part AR of the string makes an angle of 30° with the vertical, the part BR makes an angle of 40° with the vertical and the string is taut. The ring is in equilibrium.

Find the tension in the string and find the value of m .

[5]

21. [9709/w23/43/q5]

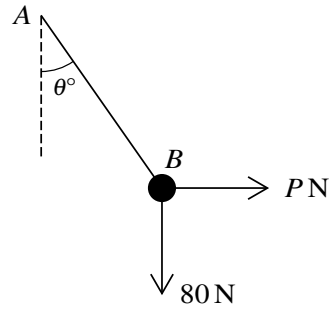

A light string AB is fixed at A and has a particle of weight 80 N attached at B . A horizontal force of magnitude P N is applied at B such that the string makes an angle θ° to the vertical (see diagram).

(a) It is given that $P = 32$ and the system is in equilibrium.

Find the tension in the string and the value of θ . [4]

(b) It is given instead that the tension in the string is 120 N and that the particle attached at B still has weight 80 N.

Find the value of P and the value of θ . [4]

22. [9709/m22/42/q5]

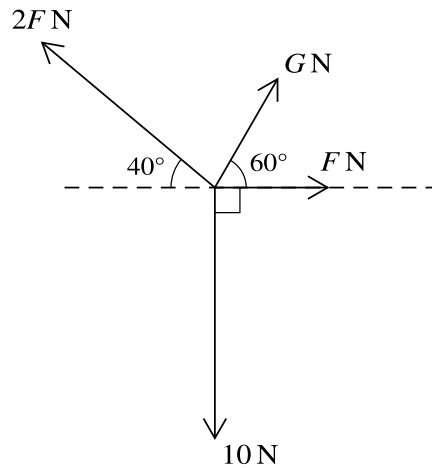

Four coplanar forces act at a point. The magnitudes of the forces are 10 N , $F\text{ N}$, $G\text{ N}$ and $2F\text{ N}$. The directions of the forces are as shown in the diagram.

- (a) Given that the forces are in equilibrium, find the values of F and G . [5]
- (b) Given instead that $F = 3$, find the value of G for which the resultant of the forces is perpendicular to the 10 N force. [2]

23. [9709/s22/41/q4]

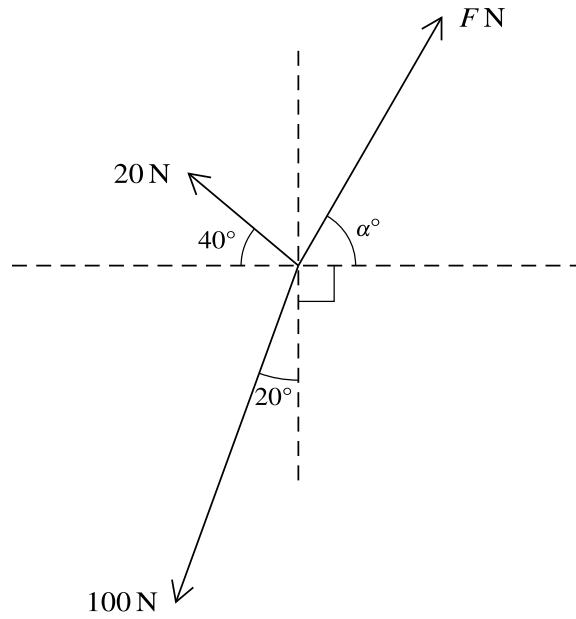

Three coplanar forces of magnitudes 20 N, 100 N and F N act at a point. The directions of these forces are shown in the diagram.

Given that the three forces are in equilibrium, find F and α .

[6]

24. [9709/s22/42/q5]

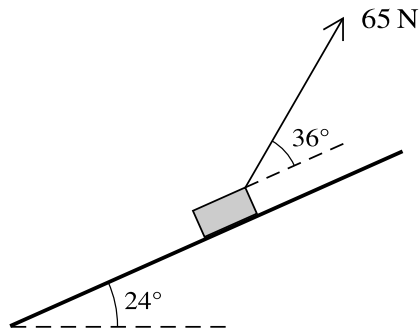

A block of mass 12 kg is placed on a plane which is inclined at an angle of 24° to the horizontal. A light string, making an angle of 36° above a line of greatest slope, is attached to the block. The tension in the string is 65 N (see diagram). The coefficient of friction between the block and plane is μ . The block is in limiting equilibrium and is on the point of sliding up the plane.

Find μ .

[6]

25. [9709/s22/43/q4]

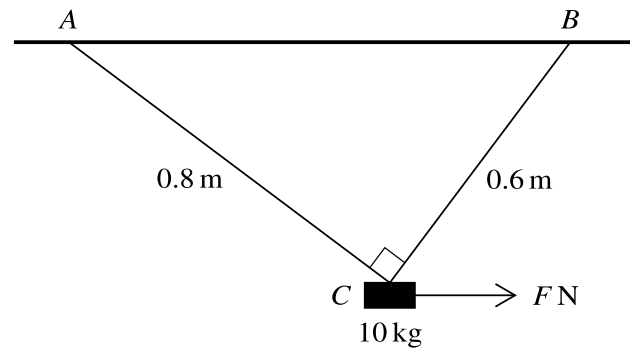

The diagram shows a block of mass 10 kg suspended below a horizontal ceiling by two strings AC and BC , of lengths 0.8 m and 0.6 m respectively, attached to fixed points on the ceiling. Angle $ACB = 90^\circ$. There is a horizontal force of magnitude F N acting on the block. The block is in equilibrium.

(a) In the case where $F = 20$, find the tensions in each of the strings. [5]

(b) Find the greatest value of F for which the block remains in equilibrium in the position shown. [3]

26. [9709/w22/41/q1]

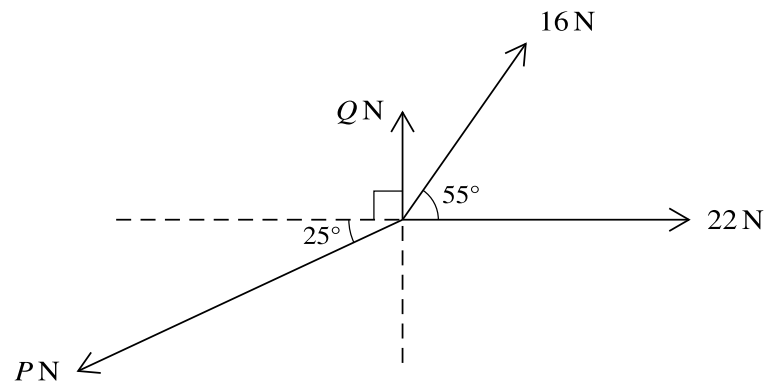

Coplanar forces of magnitudes P N, Q N, 16 N and 22 N act at a point in the directions shown in the diagram. The forces are in equilibrium.

Find the values of P and Q .

[5]

27. [9709/w22/42/q3]

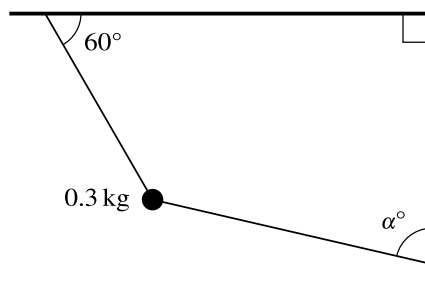

A particle of mass 0.3 kg is held at rest by two light inextensible strings. One string is attached at an angle of 60° to a horizontal ceiling. The other string is attached at an angle α° to a vertical wall (see diagram). The tension in the string attached to the ceiling is 4 N.

Find the tension in the string which is attached to the wall and find the value of α . [6]

28. [9709/w22/43/q3]

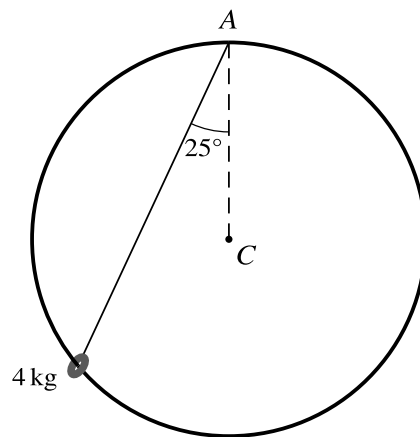

A ring of mass 4 kg is threaded on a smooth circular rigid wire with centre C . The wire is fixed in a vertical plane and the ring is kept at rest by a light string connected to A , the highest point of the circle. The string makes an angle of 25° to the vertical (see diagram).

Find the tension in the string and the magnitude of the normal reaction of the wire on the ring. [6]

29. [9709/m21/42/q3]

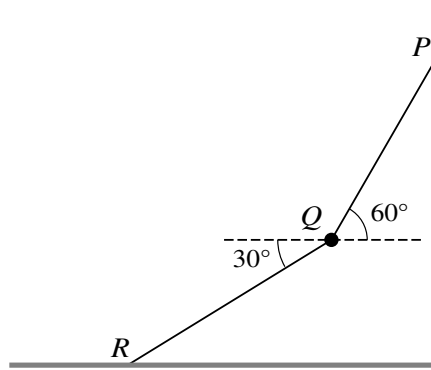

A particle Q of mass 0.2 kg is held in equilibrium by two light inextensible strings PQ and QR . P is a fixed point on a vertical wall and R is a fixed point on a horizontal floor. The angles which strings PQ and QR make with the horizontal are 60° and 30° respectively (see diagram).

Find the tensions in the two strings.

[5]

30. [9709/s21/41/q6]

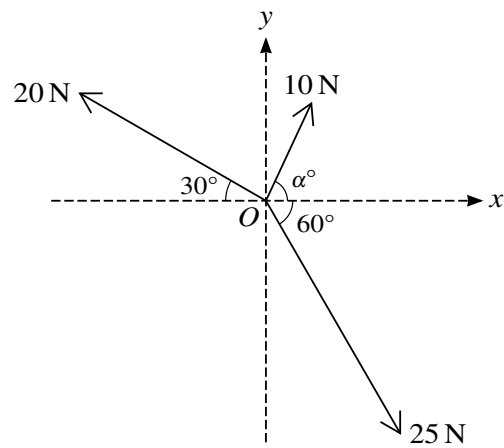

Three coplanar forces of magnitudes 10 N, 25 N and 20 N act at a point O in the directions shown in the diagram.

- (a) Given that the component of the resultant force in the x -direction is zero, find α , and hence find the magnitude of the resultant force. [4]
- (b) Given instead that $\alpha = 45$, find the magnitude and direction of the resultant of the three forces. [5]

31. [9709/s21/42/q2]

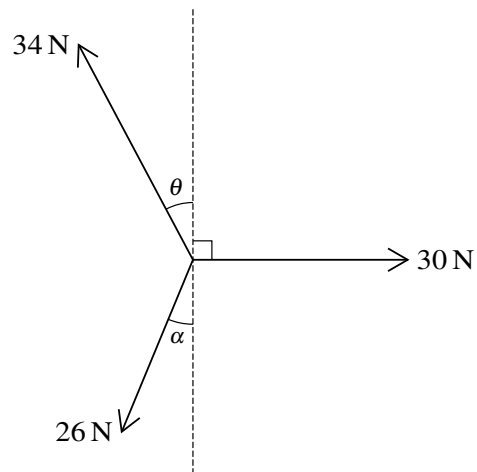

Coplanar forces of magnitudes 34 N, 30 N and 26 N act at a point in the directions shown in the diagram.

Given that $\sin \alpha = \frac{5}{13}$ and $\sin \theta = \frac{8}{17}$, find the magnitude and direction of the resultant of the three forces. [6]

32. [9709/s21/43/q3]

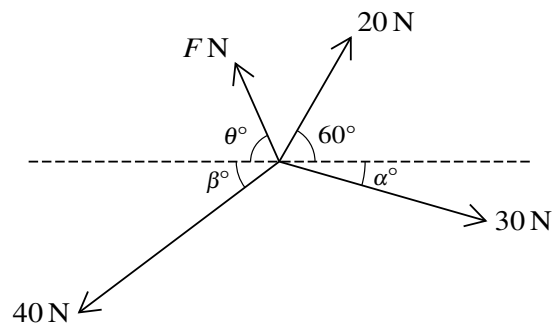

Four coplanar forces act at a point. The magnitudes of the forces are 20 N, 30 N, 40 N and F N. The directions of the forces are as shown in the diagram, where $\sin \alpha^\circ = 0.28$ and $\sin \beta^\circ = 0.6$.

Given that the forces are in equilibrium, find F and θ .

[6]

33. [9709/w21/41/q3]

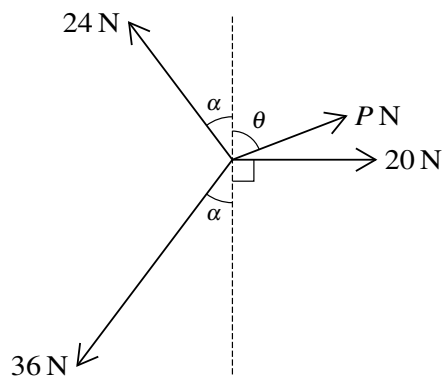

Coplanar forces of magnitudes 24 N, P N, 20 N and 36 N act at a point in the directions shown in the diagram. The system is in equilibrium.

Given that $\sin \alpha = \frac{3}{5}$, find the values of P and θ . [6]

34. [9709/w21/42/q6]

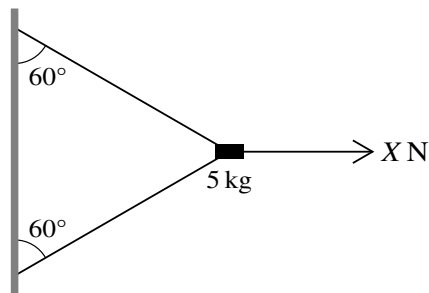

A block of mass 5 kg is held in equilibrium near a vertical wall by two light strings and a horizontal force of magnitude X N, as shown in the diagram. The two strings are both inclined at 60° to the vertical.

- (a) Given that $X = 100$, find the tension in the lower string. [4]
- (b) Find the least value of X for which the block remains in equilibrium in the position shown. [4]

35. [9709/w21/43/q2]

A particle of mass 8 kg is suspended in equilibrium by two light inextensible strings which make angles of 60° and 45° above the horizontal.

(a) Draw a diagram showing the forces acting on the particle. [1]

(b) Find the tensions in the strings. [6]

36. [9709/m20/42/q5]

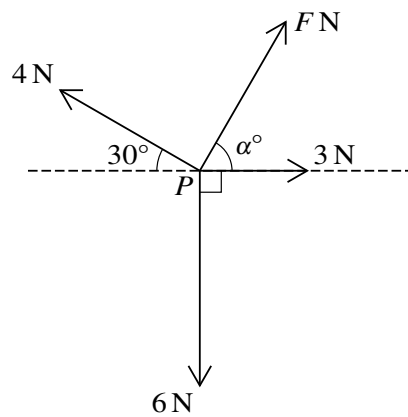

Coplanar forces, of magnitudes F N, 3 N, 6 N and 4 N, act at a point P , as shown in the diagram.

- (a) Given that $\alpha = 60$, and that the resultant of the four forces is in the direction of the 3 N force, find F . [3]
- (b) Given instead that the four forces are in equilibrium, find the values of F and α . [5]

37. [9709/s20/41/q1]

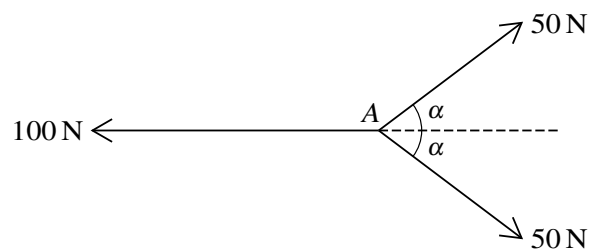

Three coplanar forces of magnitudes 100 N, 50 N and 50 N act at a point A, as shown in the diagram. The value of $\cos \alpha$ is $\frac{4}{5}$.

Find the magnitude of the resultant of the three forces and state its direction.

[3]

38. [9709/s20/42/q2]

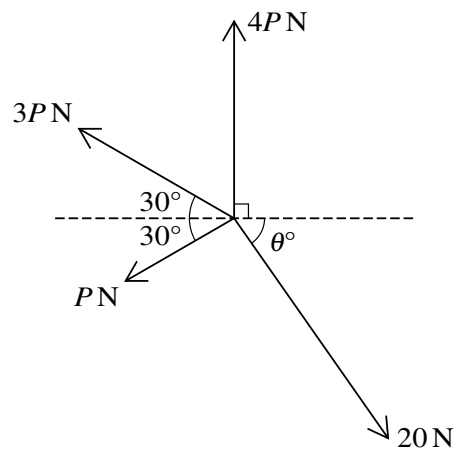

Coplanar forces of magnitudes 20 N , $P\text{ N}$, $3P\text{ N}$ and $4P\text{ N}$ act at a point in the directions shown in the diagram. The system is in equilibrium.

Find P and θ .

[6]

39. [9709/s20/43/q3]

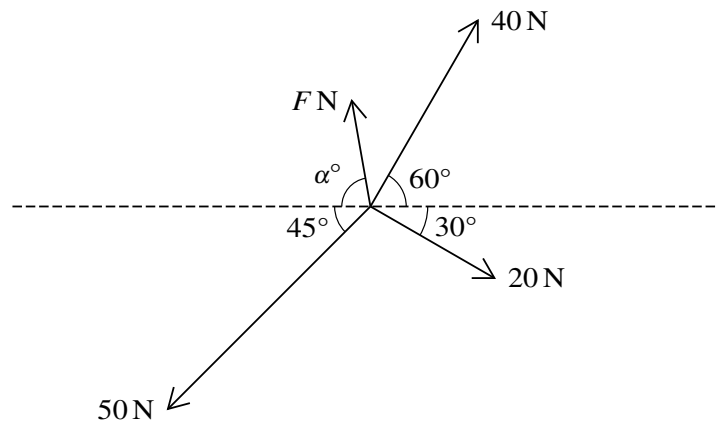

Four coplanar forces of magnitudes 40 N, 20 N, 50 N and F N act at a point in the directions shown in the diagram. The four forces are in equilibrium.

Find F and α .

[6]

40. [9709/w20/41/q3]

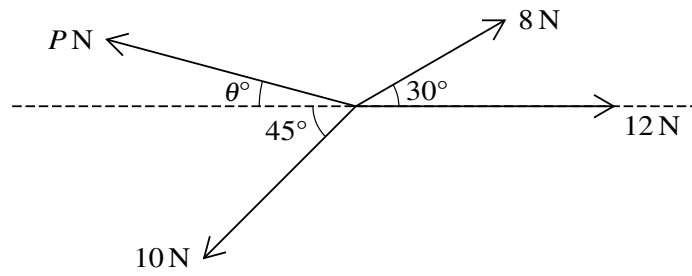

Coplanar forces of magnitudes 8 N, 12 N, 10 N and P N act at a point in the directions shown in the diagram. The system is in equilibrium.

Find P and θ .

[6]

41. [9709/w20/42/q3]

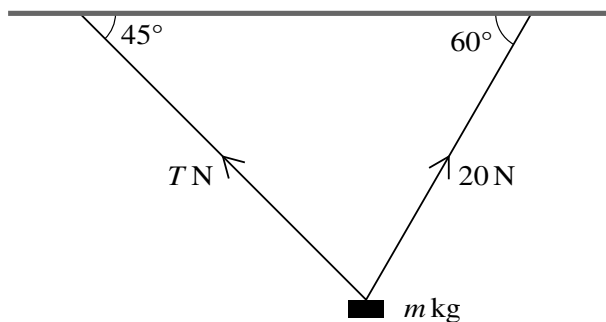

A block of mass $m\text{ kg}$ is held in equilibrium below a horizontal ceiling by two strings, as shown in the diagram. One of the strings is inclined at 45° to the horizontal and the tension in this string is $T\text{ N}$. The other string is inclined at 60° to the horizontal and the tension in this string is 20 N .

Find T and m .

[5]

42. [9709/w20/43/q3]

A string is attached to a block of mass 4 kg which rests in limiting equilibrium on a rough horizontal table. The string makes an angle of 24° above the horizontal and the tension in the string is 30 N.

(a) Draw a diagram showing all the forces acting on the block. [1]

(b) Find the coefficient of friction between the block and the table. [5]

43. [9709/m19/42/q3]

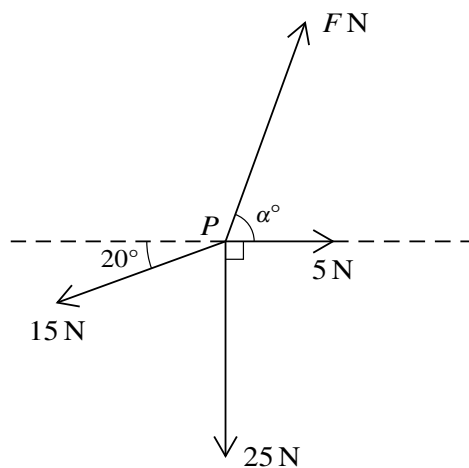

Four coplanar forces of magnitudes F N, 5 N, 25 N and 15 N are acting at a point P in the directions shown in the diagram. Given that the forces are in equilibrium, find the values of F and α . [6]

44. [9709/s19/41/q1]

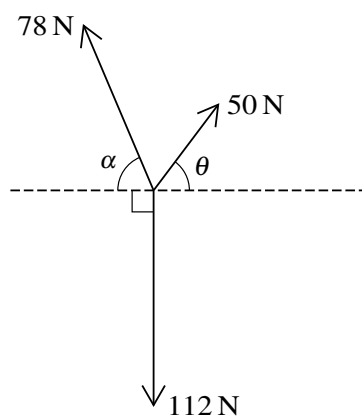

Given that $\tan \alpha = \frac{12}{5}$ and $\tan \theta = \frac{4}{3}$, show that the coplanar forces shown in the diagram are in equilibrium. [3]

45. [9709/s19/42/q1]

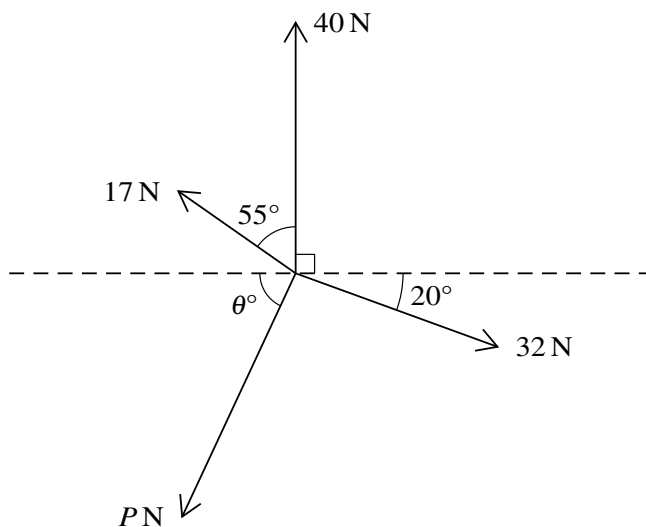

Coplanar forces of magnitudes 40 N, 32 N, P N and 17 N act at a point in the directions shown in the diagram. The system is in equilibrium. Find the values of P and θ . [6]

46. [9709/s19/43/q2]

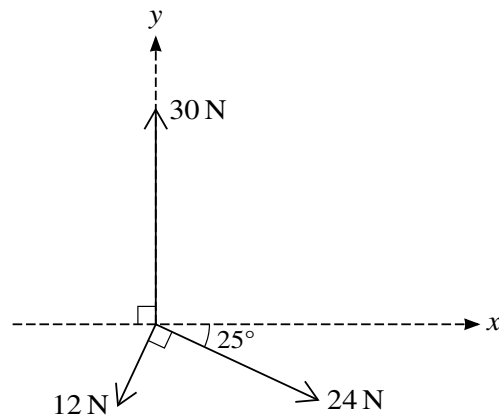

Coplanar forces of magnitudes 12 N, 24 N and 30 N act at a point in the directions shown in the diagram.

- (i) Find the components of the resultant of the three forces in the x -direction and in the y -direction. [4]

Component in x -direction.....

Component in y -direction.....

- (ii) Hence find the direction of the resultant. [2]

47. [9709/w19/41/q5]

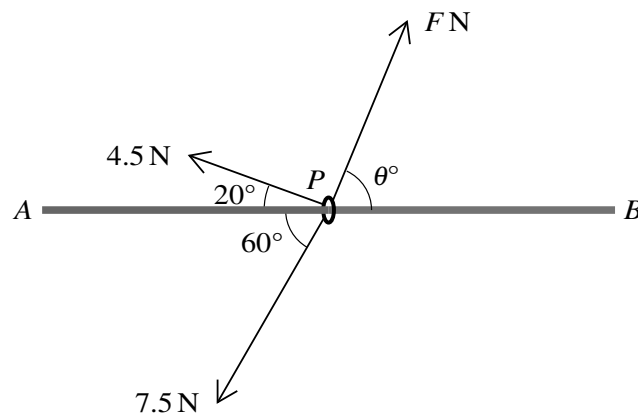

A small ring P is threaded on a fixed smooth horizontal rod AB . Three horizontal forces of magnitudes 4.5 N, 7.5 N and F N act on P (see diagram).

- (i) Given that these three forces are in equilibrium, find the values of F and θ . [6]
- (ii) It is given instead that the values of F and θ are 9.5 and 30 respectively, and the acceleration of the ring is 1.5 m s^{-2} . Find the mass of the ring. [2]

48. [9709/w19/42/q3]

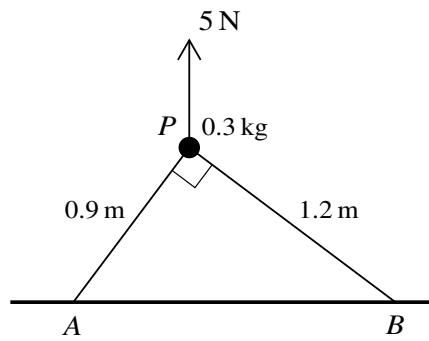

A particle P of mass 0.3 kg is held in equilibrium above a horizontal plane by a force of magnitude 5 N , acting vertically upwards. The particle is attached to two strings PA and PB of lengths 0.9 m and 1.2 m respectively. The points A and B lie on the plane and angle $APB = 90^\circ$ (see diagram). Find the tension in each of the strings. [5]

49. [9709/w19/43/q3]

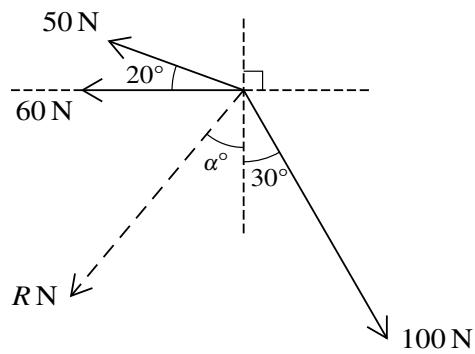

Three coplanar forces of magnitudes 50 N, 60 N and 100 N act at a point. The resultant of the forces has magnitude R N. The directions of these forces are shown in the diagram. Find the values of R and α . [6]

50. [9709/m18/42/q2]

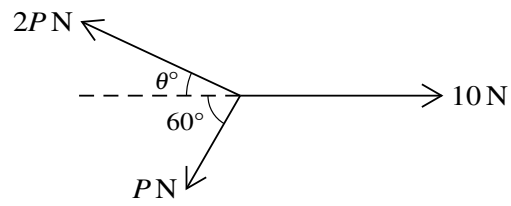

The three coplanar forces shown in the diagram are in equilibrium. Find the values of θ and P . [4]

51. [9709/s18/41/q2]

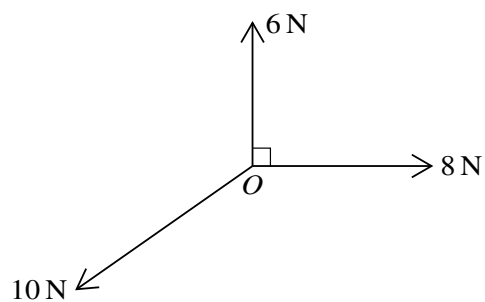

The diagram shows three coplanar forces acting at the point O . The magnitudes of the forces are 6 N , 8 N and 10 N . The angle between the 6 N force and the 8 N force is 90° . The forces are in equilibrium. Find the other angles between the forces. [4]

52. [9709/s18/42/q3]

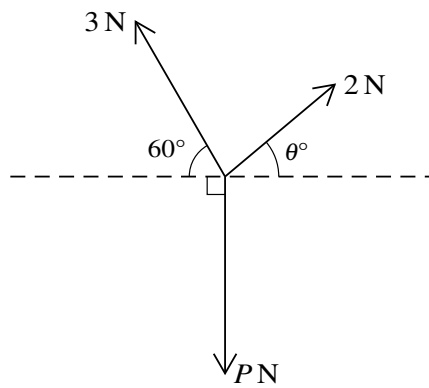

The three coplanar forces shown in the diagram have magnitudes 3 N , 2 N and $P\text{ N}$. Given that the three forces are in equilibrium, find the values of θ and P . [4]

53. [9709/s18/43/q3]

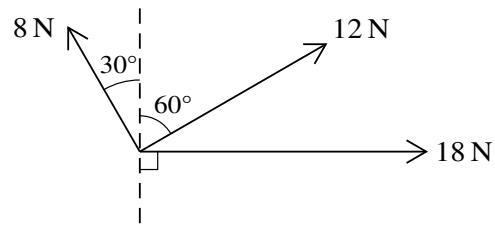

Coplanar forces of magnitudes 8 N, 12 N and 18 N act at a point in the directions shown in the diagram. Find the magnitude and direction of the single additional force acting at the same point which will produce equilibrium. [6]

54. [9709/w18/41/q5]

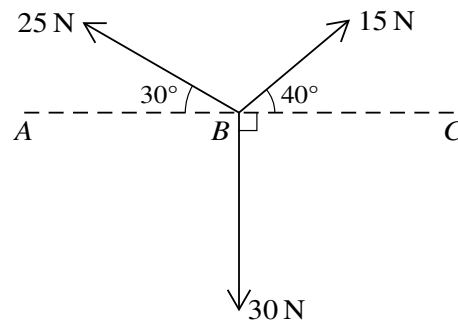

Coplanar forces, of magnitudes 15 N, 25 N and 30 N, act at a point B on the line ABC in the directions shown in the diagram.

- (i) Find the magnitude and direction of the resultant force. [6]
- (ii) The force of magnitude 15 N is now replaced by a force of magnitude F N acting in the same direction. The new resultant force has zero component in the direction BC . Find the value of F , and find also the magnitude and direction of the new resultant force. [3]

55. [9709/w18/42/q1]

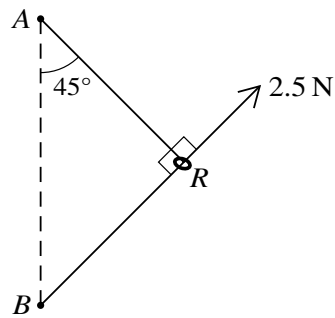

A smooth ring R of mass m kg is threaded on a light inextensible string ARB . The ends of the string are attached to fixed points A and B with A vertically above B . The string is taut and angle $ARB = 90^\circ$. The angle between the part AR of the string and the vertical is 45° . The ring is held in equilibrium in this position by a force of magnitude 2.5 N, acting on the ring in the direction BR (see diagram). Calculate the tension in the string and the mass of the ring. [4]

56. [9709/w18/43/q1]

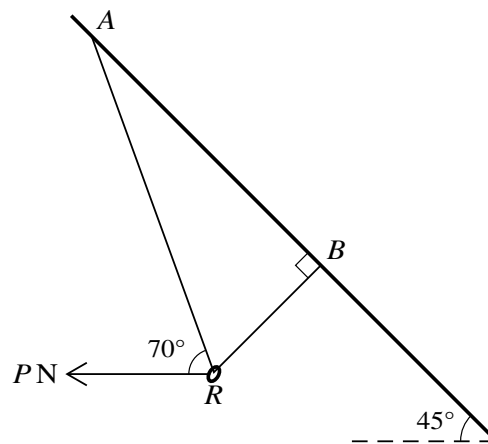

A small smooth ring R of mass 0.2 kg is threaded onto a light inextensible string ARB . The two ends of the string are attached to points A and B on a sloping roof inclined at 45° to the horizontal. A horizontal force of magnitude PN , acting in the plane ARB , is applied to the ring. The section BR of the string is perpendicular to the roof and the section AR of the string is inclined at 70° to the horizontal (see diagram). The system is in equilibrium. Find the tension in the string and the value of P . [4]

57. [9709/m17/42/q2]

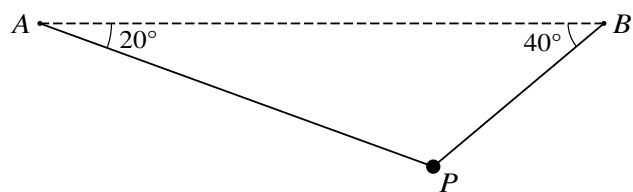

A particle P of mass 1.6 kg is suspended in equilibrium by two light inextensible strings attached to points A and B . The strings make angles of 20° and 40° respectively with the horizontal (see diagram). Find the tensions in the two strings. [6]

58. [9709/s17/41/q3]

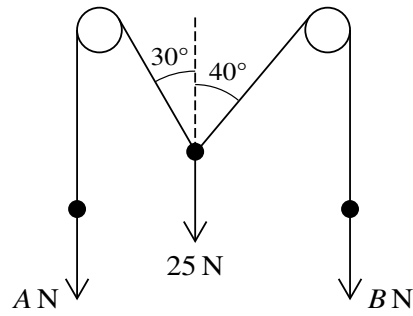

Two light inextensible strings are attached to a particle of weight 25 N . The strings pass over two smooth fixed pulleys and have particles of weights $A\text{ N}$ and $B\text{ N}$ hanging vertically at their ends. The sloping parts of the strings make angles of 30° and 40° respectively with the vertical (see diagram). The system is in equilibrium. Find the values of A and B . [6]

59. [9709/s17/43/q2]

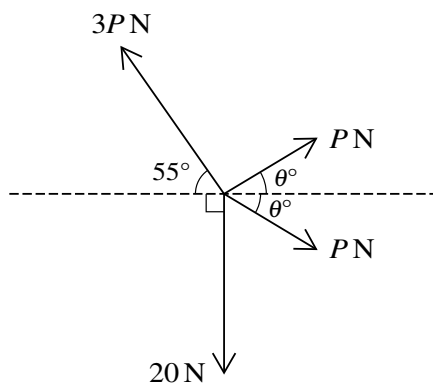

The four coplanar forces shown in the diagram are in equilibrium. Find the values of P and θ . [5]

60. [9709/w17/41/q6]

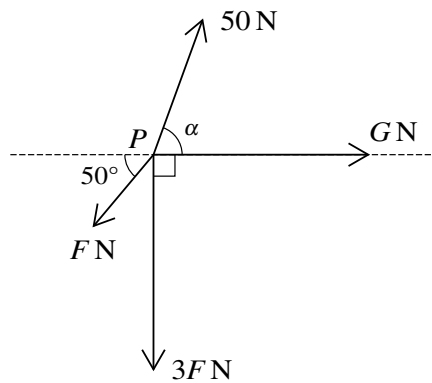

Coplanar forces, of magnitudes F N, $3F$ N, G N and 50 N, act at a point P , as shown in the diagram.

(i) Given that $F = 0$, $G = 75$ and $\alpha = 60^\circ$, find the magnitude and direction of the resultant force.

[4]

(ii) Given instead that $G = 0$ and the forces are in equilibrium, find the values of F and α .

[5]

61. [9709/w17/42/q2]

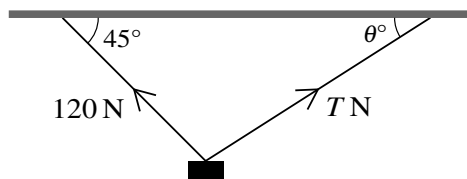

A block of mass 15 kg hangs in equilibrium below a horizontal ceiling attached to two strings as shown in the diagram. One of the strings is inclined at 45° to the horizontal and the tension in this string is 120 N . The other string is inclined at θ° to the horizontal and the tension in this string is $T\text{ N}$. Find the values of T and θ . [6]

62. [9709/w17/43/q1]

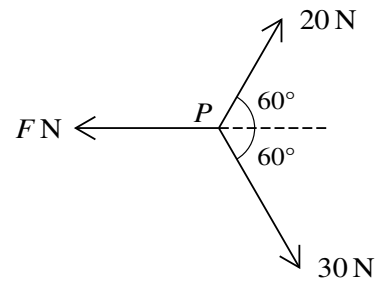

Three coplanar forces of magnitudes F N, 20 N and 30 N act at a point P , as shown in the diagram. The resultant of the three forces acts in a direction perpendicular to the force of magnitude F N. Find the value of F . [3]

63. [9709/m16/42/q3]

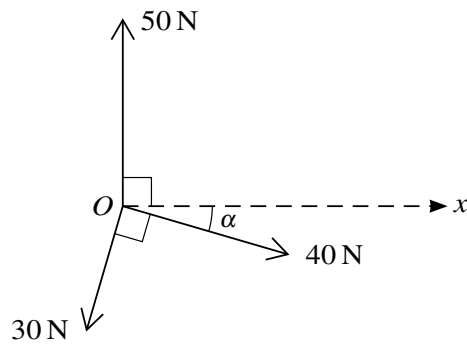

Coplanar forces of magnitudes 50 N, 40 N and 30 N act at a point O in the directions shown in the diagram, where $\tan \alpha = \frac{7}{24}$.

- (i) Find the magnitude and direction of the resultant of the three forces. [6]
- (ii) The force of magnitude 50 N is replaced by a force of magnitude P N acting in the same direction. The resultant of the three forces now acts in the positive x -direction. Find the value of P . [1]

64. [9709/s16/41/q4]

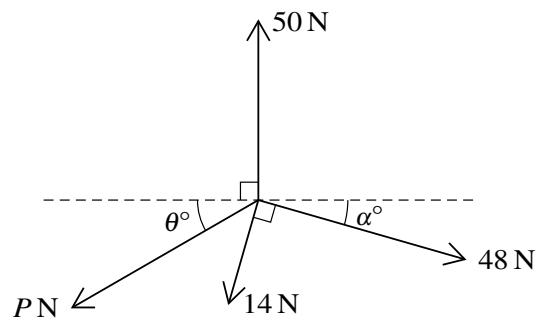

Coplanar forces of magnitudes 50 N, 48 N, 14 N and P N act at a point in the directions shown in the diagram. The system is in equilibrium. Given that $\tan \alpha = \frac{7}{24}$, find the values of P and θ . [6]

65. [9709/s16/42/q1]

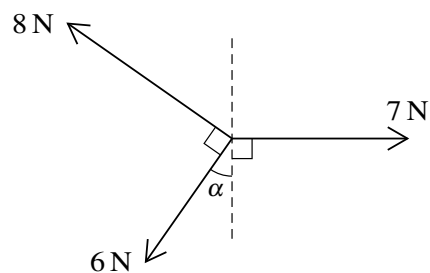

Coplanar forces of magnitudes 7 N, 6 N and 8 N act at a point in the directions shown in the diagram. Given that $\sin \alpha = \frac{3}{5}$, find the magnitude and direction of the resultant of the three forces. [5]

66. [9709/s16/43/q3]

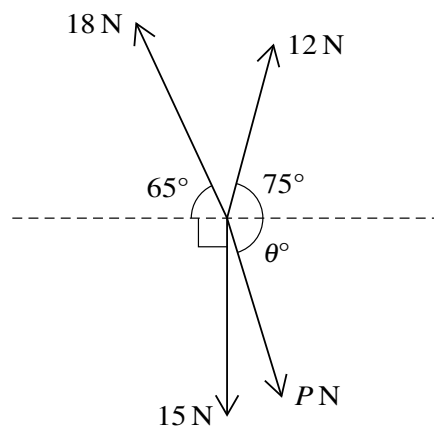

The coplanar forces shown in the diagram are in equilibrium. Find the values of P and θ . [6]

67. [9709/w16/41/q4]

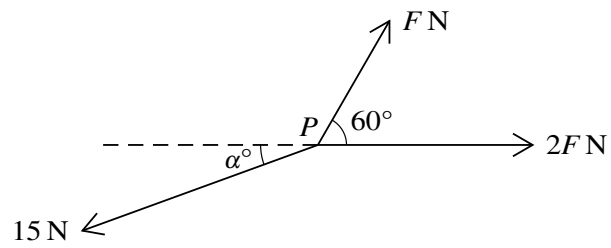

Three coplanar forces of magnitudes FN , $2FN$ and 15 N act at a point P , as shown in the diagram. Given that the forces are in equilibrium, find the values of F and α . [6]

68. [9709/w16/42/q3]

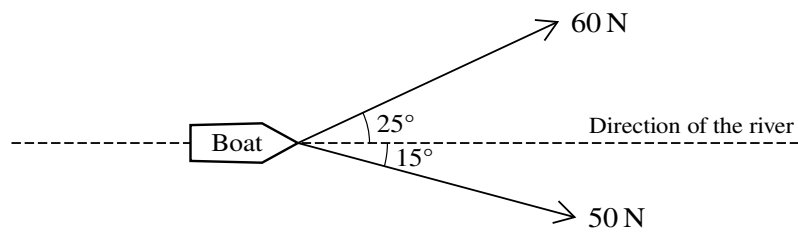

A boat is being pulled along a river by two people. One of the people walks along a path on one side of the river and the other person walks along a path on the opposite side of the river. The first person exerts a horizontal force of 60 N at an angle of 25° to the direction of the river. The second person exerts a horizontal force of 50 N at an angle of 15° to the direction of the river (see diagram).

- (i) Find the total force exerted by the two people in the direction of the river. [2]
- (ii) Find the magnitude and direction of the resultant force exerted by the two people. [4]

69. [9709/w16/43/q2]

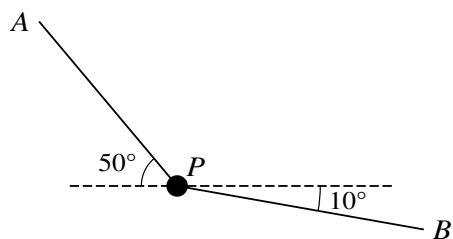

The diagram shows a small object P of mass 20 kg held in equilibrium by light ropes attached to fixed points A and B . The rope PA is inclined at an angle of 50° above the horizontal, the rope PB is inclined at an angle of 10° below the horizontal, and both ropes are in the same vertical plane. Find the tension in the rope PA and the tension in the rope PB . [5]

70. [9709/s15/41/q2]

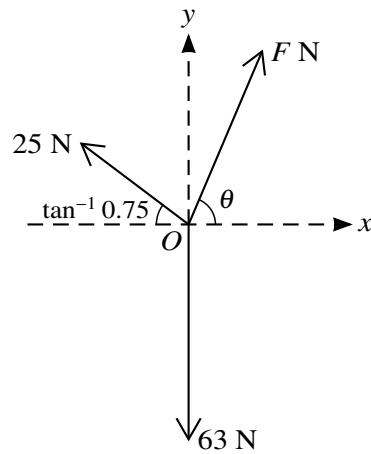

Three horizontal forces of magnitudes $F\text{ N}$, 63 N and 25 N act at O , the origin of the x -axis and y -axis. The forces are in equilibrium. The force of magnitude $F\text{ N}$ makes an angle θ anticlockwise with the positive x -axis. The force of magnitude 63 N acts along the negative y -axis. The force of magnitude 25 N acts at $\tan^{-1} 0.75$ clockwise from the negative x -axis (see diagram). Find the value of F and the value of $\tan \theta$. [5]

71. [9709/s15/42/q7]

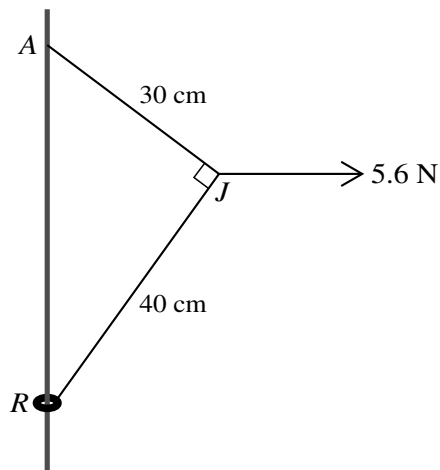

A small ring R is attached to one end of a light inextensible string of length 70 cm. A fixed rough vertical wire passes through the ring. The other end of the string is attached to a point A on the wire, vertically above R . A horizontal force of magnitude 5.6 N is applied to the point J of the string 30 cm from A and 40 cm from R . The system is in equilibrium with each of the parts AJ and JR of the string taut and angle AJR equal to 90° (see diagram).

(i) Find the tension in the part AJ of the string, and find the tension in the part JR of the string. [5]

The ring R has mass 0.2 kg and is in limiting equilibrium, on the point of moving up the wire.

(ii) Show that the coefficient of friction between R and the wire is 0.341, correct to 3 significant figures. [4]

A particle of mass m kg is attached to R and R is now in limiting equilibrium, on the point of moving down the wire.

(iii) Given that the coefficient of friction is unchanged, find the value of m . [3]

72. [9709/s15/43/q5]

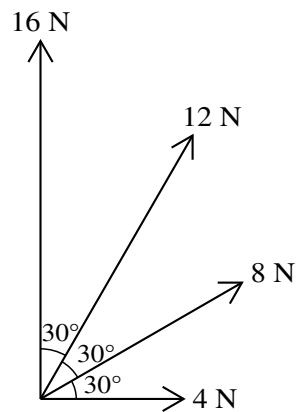
**Fig. 1**

Four coplanar forces of magnitudes 4 N, 8 N, 12 N and 16 N act at a point. The directions in which the forces act are shown in Fig. 1.

- (i) Find the magnitude and direction of the resultant of the four forces. [5]

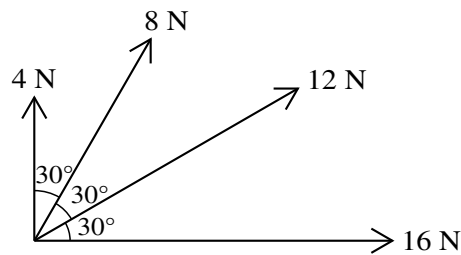
**Fig. 2**

The forces of magnitudes 4 N and 16 N exchange their directions and the forces of magnitudes 8 N and 12 N also exchange their directions (see Fig. 2).

- (ii) State the magnitude and direction of the resultant of the four forces in Fig. 2. [2]

73. [9709/w15/41/q5]

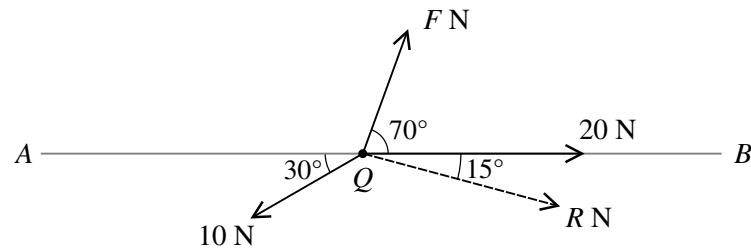

A small bead Q can move freely along a smooth horizontal straight wire AB of length 3 m. Three horizontal forces of magnitudes F N, 10 N and 20 N act on the bead in the directions shown in the diagram. The magnitude of the resultant of the three forces is R N in the direction shown in the diagram.

- (i) Find the values of F and R . [5]
- (ii) Initially the bead is at rest at A . It reaches B with a speed of 11.7 m s^{-1} . Find the mass of the bead. [3]

74. [9709/w15/42/q1]

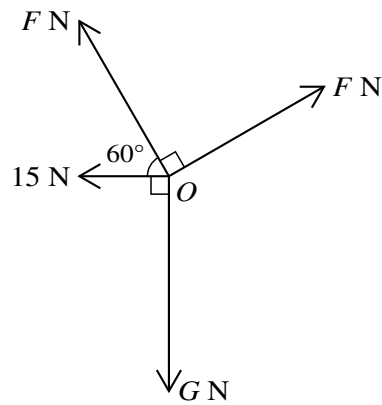

Four horizontal forces act at a point O and are in equilibrium. The magnitudes of the forces are F N, G N, 15 N and F N, and the forces act in directions as shown in the diagram.

(i) Show that $F = 41.0$, correct to 3 significant figures. [3]

(ii) Find the value of G . [2]

75. [9709/w15/43/q3]

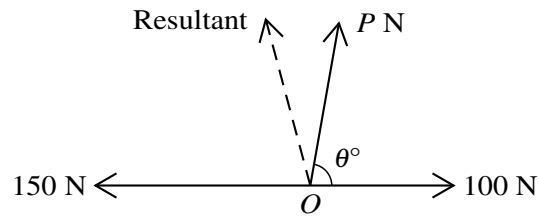

Three horizontal forces of magnitudes 150 N, 100 N and P N have directions as shown in the diagram. The resultant of the three forces is shown by the broken line in the diagram. This resultant has magnitude 120 N and makes an angle 75° with the 150 N force. Find the values of P and θ . [7]

Chapter 5

Friction

1. [9709/m25/42/q6]

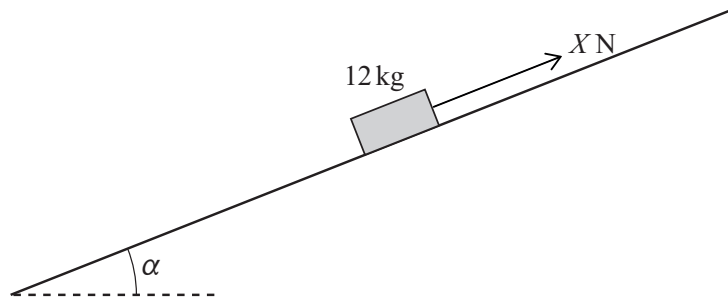

A block of mass 12 kg is placed on a rough plane inclined at an angle of α to the horizontal, where $\alpha = \tan^{-1}0.5$. A force of X N is applied to the block, directly up the plane (see diagram). The coefficient of friction between the block and the plane is μ .

(a) It is given that $\mu = 0.15$ and $X = 20$.

Find the time that it takes for the block to move 2 m down the plane from rest. [6]

(b) It is given instead that $\mu \neq 0.15$ and that when $X = 10$, the block is on the point of moving **down** the plane.

Find the value of μ and the value of X for which the block is on the point of moving **up** the plane. [4]

2. [9709/s25/41/q1]

A block of mass 12 kg is being pulled by a rope up a rough plane. The plane is inclined at an angle of 20° above the horizontal. The rope pulling the block is parallel to a line of greatest slope of the plane. The coefficient of friction between the block and the plane is 0.4. The acceleration of the block is 2 m s^{-2} .

Find the tension in the rope.

[4]

3. [9709/w25/41/q5]

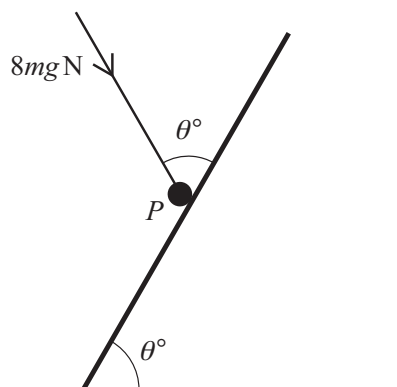

A particle P of mass m kg is in equilibrium on a rough plane inclined at an angle θ° to the horizontal. The equilibrium of P is maintained by a force of magnitude $8mg\text{N}$ making an angle θ° with a line of greatest slope (see diagram). The coefficient of friction between P and the plane is 0.5 and P is on the point of slipping down the plane.

Find the value of θ .

[6]

4. [9709/w25/41/q8]

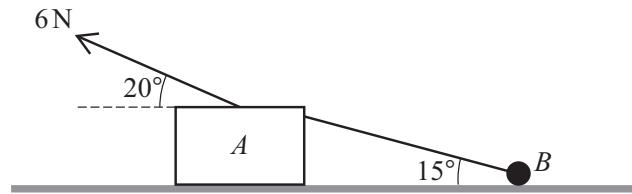

A block A of mass 2 kg and a particle B of mass 0.5 kg are connected by a light inextensible string inclined at 15° to the horizontal. They are pulled across a horizontal surface with acceleration 1.2 m s^{-2} by a force of magnitude 6 N , applied to A , acting at 20° above the horizontal as shown in the diagram. The string and the force applied to A are in the same vertical plane.

The contact between B and the surface is smooth and the contact between A and the surface is rough.

- (a) Find the tension in the string. [2]
- (b) Find the coefficient of friction between A and the surface. [6]

5. [9709/w25/42/q5]

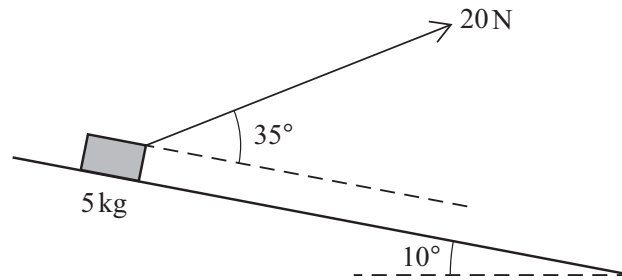

A block of mass 5 kg is being pulled straight down a line of greatest slope of a rough plane by a force of magnitude 20 N . The plane is inclined at an angle of 10° to the horizontal and the 20 N force acts at an angle of 35° above the line of greatest slope of the plane (see diagram). The coefficient of friction between the block and the plane is 0.4 . The speed of the block when it passes a point O is 2 m s^{-1} .

Find the speed of the block when it has moved 3 m down the plane from O .

[6]

6. [9709/w25/43/q7]

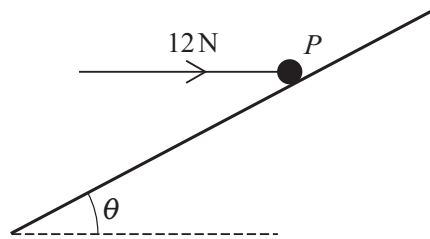

A particle P of mass 6 kg lies on a rough plane inclined at an acute angle θ to the horizontal. A horizontal force of magnitude 12 N acts on P as shown in the diagram. The line of action of this horizontal force lies in a vertical plane which contains the line of greatest slope of the plane that passes through P . The coefficient of friction between P and the plane is μ .

P is in equilibrium and on the point of sliding down the plane.

(a) Show that $\mu = \frac{5 \tan \theta - 1}{5 + \tan \theta}$. [5]

(b) Hence find the set of possible values of θ . [2]

7. [9709/w25/45/q5]

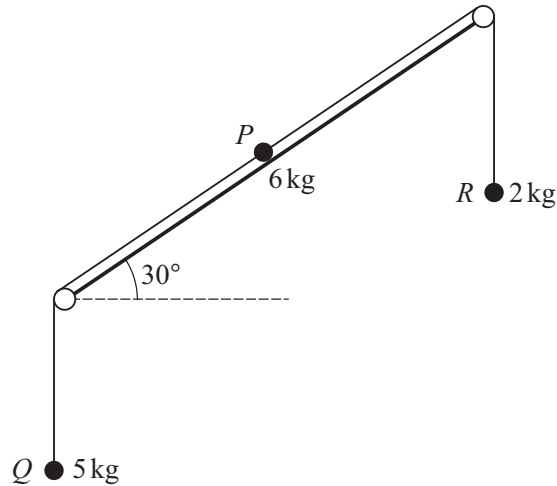

The diagram shows a particle P of mass 6 kg on a rough plane inclined at an angle of 30° to the horizontal. Two light inextensible strings are attached to P . The strings pass over small smooth pulleys, which are fixed at the ends of the plane. The non-vertical parts of the string are parallel to a line of greatest slope of the plane. Particles Q and R , of masses 5 kg and 2 kg respectively, hang vertically at the ends of the strings.

Both strings are taut, and the system is released from rest.

It is given that the tension in the string attached to Q is twice the tension in the string attached to R .

- (a) Find, in terms of g , the tension in each of the strings and the magnitude of the acceleration of the particles. [5]
- (b) Find the coefficient of friction between P and the plane. [5]
- (c) It is given that when the system is released from rest, P is at the midpoint of the plane. In the subsequent motion, R does not reach the pulley at the top of the plane, and P takes 1.5 s to reach the pulley at the bottom of the plane.

Find the total length of the plane. [2]

8. [9709/m24/42/q3]

A crate of mass 600 kg is being pulled up a line of greatest slope of a rough plane at a constant speed of 2 m s^{-1} by a rope attached to a winch. The plane is inclined at an angle of 30° to the horizontal and the rope is parallel to the plane. The winch is working at a constant rate of 8 kW.

Find the coefficient of friction between the crate and the plane.

[5]

9. [9709/s24/41/q5]

A straight slope of length 60 m is inclined at an angle of 12° to the horizontal. A bobsled starts at the top of the slope with a speed of 5 m s^{-1} . The bobsled slides directly down the slope.

- (a) It is given that there is no resistance to the bobsled's motion.

Find its speed when it reaches the bottom of the slope. [3]

- (b) It is given instead that the coefficient of friction between the bobsled and the slope is 0.03 .

Find the time that it takes for the bobsled to reach the bottom of the slope. [5]

10. [9709/s24/42/q5]

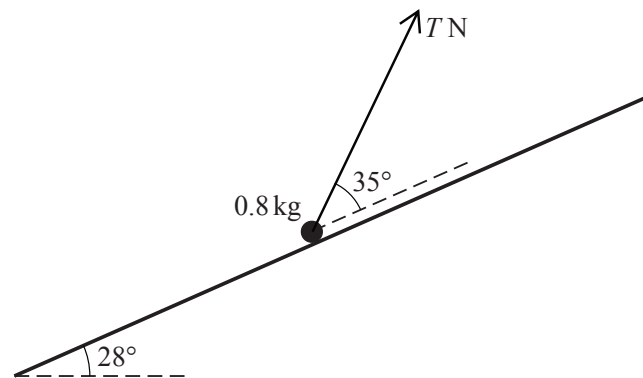

A particle of mass 0.8 kg lies on a rough plane which is inclined at an angle of 28° to the horizontal. The particle is kept in equilibrium by a force of magnitude $T \text{ N}$. This force acts at an angle of 35° above a line of greatest slope of the plane (see diagram). The coefficient of friction between the particle and the plane is 0.2 .

Find the least and greatest possible values of T .

[8]

11. [9709/s24/43/q7]



The diagram shows a track $ABCD$ which lies in a vertical plane. The section AB is a straight line inclined at an angle of 30° to the horizontal and is smooth. The section BC is a horizontal straight line and is rough. The section CD is a straight line inclined at an angle of 30° to the horizontal and is rough. The lengths AB , BC and CD are each 2 m.

A particle is released from rest at A . The coefficient of friction between the particle and both BC and CD is μ . There is no change in the speed of the particle when it passes through either of the points B or C .

(a) It is given that $\mu = 0.1$.

Find the distance which the particle has moved up the section CD when its speed is 1 m s^{-1} . [5]

(b) It is given instead that with a different value of μ the particle travels 1 m up the track from C before it comes instantaneously to rest.

Find the value of μ and the speed of the particle at the instant that it passes C for the second time. [4]

12. [9709/w24/41/q2]

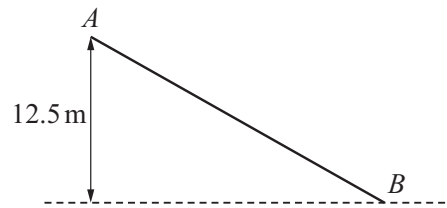

A particle of mass 7.5 kg , starting from rest at A , slides down an inclined plane AB . The point B is 12.5 metres vertically below the level of A , as shown in the diagram.

- (a) Given that the plane is smooth, use an energy method to find the speed of the particle at B . [2]
- (b) It is given instead that the plane is rough and the particle reaches B with a speed of 8 m s^{-1} . The plane is 25 m long and the constant frictional force has magnitude FN .

Find the value of F . [3]

13. [9709/w24/41/q6]

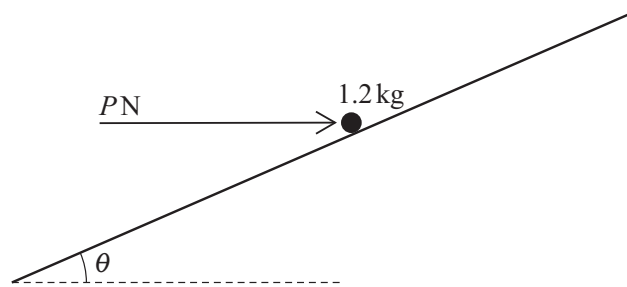

A particle of mass 1.2 kg is placed on a rough plane which is inclined at an angle θ to the horizontal, where $\sin \theta = \frac{7}{25}$. The particle is kept in equilibrium by a horizontal force of magnitude P N acting in a vertical plane containing a line of greatest slope (see diagram). The coefficient of friction between the particle and the plane is 0.15 .

Find the least possible value of P .

[6]

14. [9709/w24/43/q5]

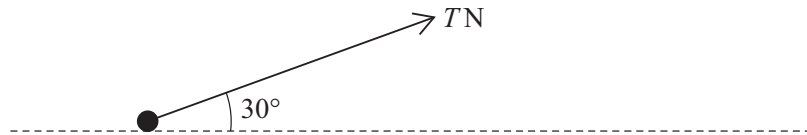

A particle of mass 12 kg is going to be pulled across a rough horizontal plane by a light inextensible string. The string is at an angle of 30° above the plane and has tension $T\text{ N}$ (see diagram). The coefficient of friction between the particle and the plane is 0.5 .

- (a) Given that the particle is on the point of moving, find the value of T . [5]
- (b) Given instead that the particle is accelerating at 0.2 m s^{-2} , find the value of T . [3]

15. [9709/m23/42/q6]

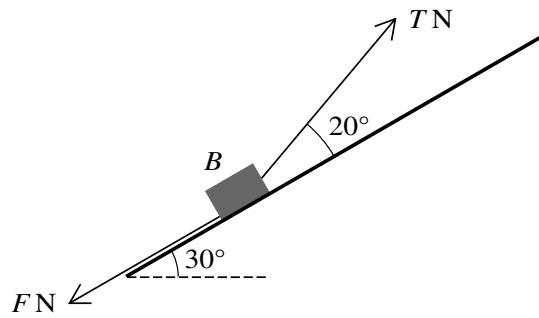

A block B , of mass 2 kg , lies on a rough inclined plane sloping at 30° to the horizontal. A light rope, inclined at an angle of 20° above a line of greatest slope, is attached to B . The tension in the rope is $T\text{ N}$. There is a friction force of $F\text{ N}$ acting on B (see diagram). The coefficient of friction between B and the plane is μ .

- (a) It is given that $F = 5$ and that the acceleration of B up the plane is 1.2 m s^{-2} .
- (i) Find the value of T . [3]
- (ii) Find the value of μ . [3]
- (b) It is given instead that $\mu = 0.8$ and $T = 15$.
- Determine whether B will move up the plane. [3]

16. [9709/s23/42/q5]

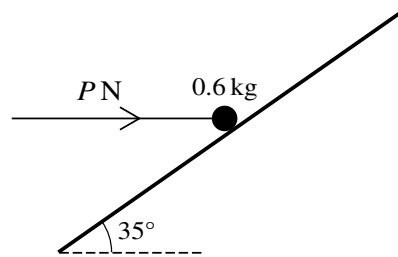

A particle of mass 0.6 kg is placed on a rough plane which is inclined at an angle of 35° to the horizontal. The particle is kept in equilibrium by a horizontal force of magnitude P N acting in a vertical plane containing a line of greatest slope (see diagram). The coefficient of friction between the particle and plane is 0.4.

Find the least possible value of P .

[6]

17. [9709/w23/41/q4]

Two particles P and Q , of masses 6 kg and 2 kg respectively, lie at rest 12.5 m apart on a rough horizontal plane. The coefficient of friction between each particle and the plane is 0.4. Particle P is projected towards Q with speed 20 m s^{-1} .

(a) Show that the speed of P immediately before the collision with Q is $10\sqrt{3} \text{ m s}^{-1}$. [3]

In the collision P and Q coalesce to form particle R .

(b) Find the loss of kinetic energy due to the collision. [4]

The coefficient of friction between R and the plane is 0.4.

(c) Find the distance travelled by particle R before coming to rest. [2]

18. [9709/w23/42/q4]

A particle P of mass 0.2 kg lies at rest on a rough horizontal plane. A horizontal force of 1.2 N is applied to P .

- (a) Given that P is in limiting equilibrium, find the coefficient of friction between P and the plane. [3]
- (b) Given instead that the coefficient of friction between P and the plane is 0.3 , find the distance travelled by P in the third second of its motion. [4]

19. [9709/w23/43/q3]

A block of mass 8 kg slides down a rough plane inclined at 30° to the horizontal, starting from rest. The coefficient of friction between the block and the plane is μ . The block accelerates uniformly down the plane at 2.4 m s^{-2} .

(a) Draw a diagram showing the forces acting on the block. [1]

(b) Find the value of μ . [4]

20. [9709/m22/42/q7]

A bead, A , of mass 0.1 kg is threaded on a long straight rigid wire which is inclined at $\sin^{-1}\left(\frac{7}{25}\right)$ to the horizontal. A is released from rest and moves down the wire. The coefficient of friction between A and the wire is μ . When A has travelled 0.45 m down the wire, its speed is 0.6 m s^{-1} .

(a) Show that $\mu = 0.25$. [6]

Another bead, B , of mass 0.5 kg is also threaded on the wire. At the point where A has travelled 0.45 m down the wire, it hits B which is instantaneously at rest on the wire. A is brought to instantaneous rest in the collision. The coefficient of friction between B and the wire is 0.275 .

(b) Find the time from when the collision occurs until A collides with B again. [6]

21. [9709/s22/41/q3]

A crate of mass 300 kg is at rest on rough horizontal ground. The coefficient of friction between the crate and the ground is 0.5. A force of magnitude X N, acting at an angle α above the horizontal, is applied to the crate, where $\sin \alpha = 0.28$.

Find the greatest value of X for which the crate remains at rest.

[5]

22. [9709/s22/42/q5]

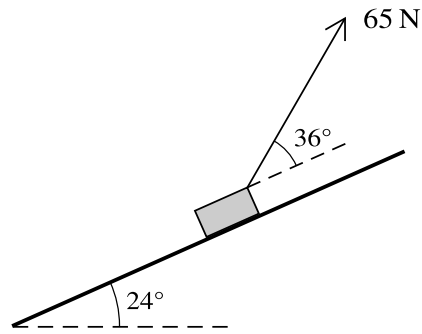

A block of mass 12 kg is placed on a plane which is inclined at an angle of 24° to the horizontal. A light string, making an angle of 36° above a line of greatest slope, is attached to the block. The tension in the string is 65 N (see diagram). The coefficient of friction between the block and plane is μ . The block is in limiting equilibrium and is on the point of sliding up the plane.

Find μ .

[6]

23. [9709/w22/42/q2]

A particle P of mass 0.4 kg is in limiting equilibrium on a plane inclined at 30° to the horizontal.

(a) Show that the coefficient of friction between the particle and the plane is $\frac{1}{3}\sqrt{3}$. [3]

A force of magnitude 7.2 N is now applied to P directly up a line of greatest slope of the plane.

(b) Given that P starts from rest, find the time that it takes for P to move 1 m up the plane. [4]

24. [9709/w22/43/q7]

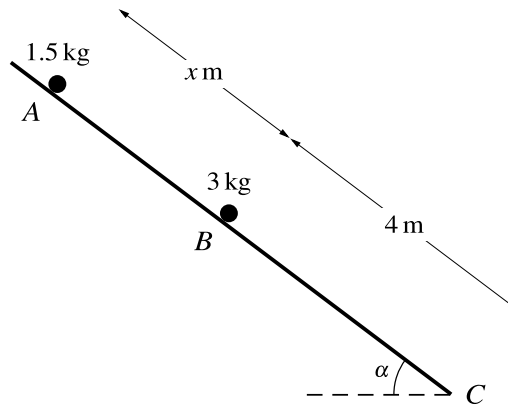

Particles of masses 1.5 kg and 3 kg lie on a plane which is inclined at an angle of α to the horizontal, where $\tan \alpha = \frac{3}{4}$. The section of the plane from A to B is smooth and the section of the plane from B to C is rough. The 1.5 kg particle is held at rest at A and the 3 kg particle is in limiting equilibrium at B . The distance AB is x m and the distance BC is 4 m (see diagram).

(a) Show that the coefficient of friction between the particle at B and the plane is 0.75. [3]

The 1.5 kg particle is released from rest. In the subsequent motion the two particles collide and coalesce. The time taken for the combined particle to travel from B to C is 2 s. The coefficient of friction between the combined particle and the plane is still 0.75.

(b) Find x . [6]

(c) Find the total loss of energy of the particles from the time the 1.5 kg particle is released until the combined particle reaches C . [3]

25. [9709/m21/42/q5]

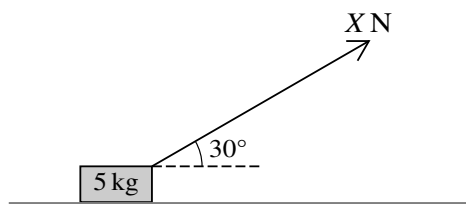

A block of mass 5 kg is being pulled along a rough horizontal floor by a force of magnitude X N acting at 30° above the horizontal (see diagram). The block starts from rest and travels 2 m in the first 5 s of its motion.

(a) Find the acceleration of the block. [2]

(b) Given that the coefficient of friction between the block and the floor is 0.4, find X . [4]

The block is now placed on a part of the floor where the coefficient of friction between the block and the floor has a different value. The value of X is changed to 25, and the block is now in limiting equilibrium.

(c) Find the value of the coefficient of friction between the block and this part of the floor. [3]

26. [9709/s21/42/q4]

A particle of mass 12 kg is stationary on a rough plane inclined at an angle of 25° to the horizontal. A pulling force of magnitude P N acts at an angle of 8° above a line of greatest slope of the plane. This force is used to keep the particle in equilibrium. The coefficient of friction between the particle and the plane is 0.3.

Find the greatest possible value of P .

[6]

27. [9709/s21/43/q7]

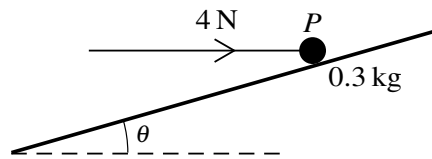

A particle P of mass 0.3 kg rests on a rough plane inclined at an angle θ to the horizontal, where $\sin \theta = \frac{7}{25}$. A horizontal force of magnitude 4 N , acting in the vertical plane containing a line of greatest slope of the plane, is applied to P (see diagram). The particle is on the point of sliding up the plane.

(a) Show that the coefficient of friction between the particle and the plane is $\frac{3}{4}$. [4]

The force acting horizontally is replaced by a force of magnitude 4 N acting up the plane parallel to a line of greatest slope.

(b) Find the acceleration of P . [3]

(c) Starting with P at rest, the force of 4 N parallel to the plane acts for 3 seconds and is then removed.

Find the total distance travelled until P comes to instantaneous rest. [3]

28. [9709/w21/41/q4]

A particle of mass 12 kg is stationary on a rough plane inclined at an angle of 25° to the horizontal. A force of magnitude P N acting parallel to a line of greatest slope of the plane is used to prevent the particle sliding down the plane. The coefficient of friction between the particle and the plane is 0.35.

(a) Draw a sketch showing the forces acting on the particle. [1]

(b) Find the least possible value of P . [5]

29. [9709/m20/42/q2]

A particle P of mass 0.4 kg is on a rough horizontal floor. The coefficient of friction between P and the floor is μ . A force of magnitude 3 N is applied to P upwards at an angle α above the horizontal, where $\tan \alpha = \frac{3}{4}$. The particle is initially at rest and accelerates at 2 m s^{-2} .

- (a) Find the time it takes for P to travel a distance of 1.44 m from its starting point. [2]
- (b) Find μ . [4]

30. [9709/s20/41/q4]

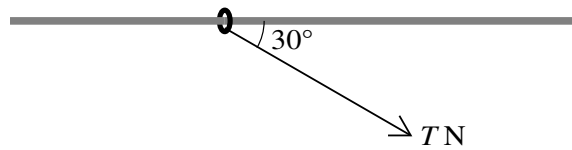

The diagram shows a ring of mass 0.1 kg threaded on a fixed horizontal rod. The rod is rough and the coefficient of friction between the ring and the rod is 0.8 . A force of magnitude T N acts on the ring in a direction at 30° to the rod, downwards in the vertical plane containing the rod. Initially the ring is at rest.

(a) Find the greatest value of T for which the ring remains at rest. [4]

(b) Find the acceleration of the ring when $T = 3$. [3]

31. [9709/s20/42/q3]

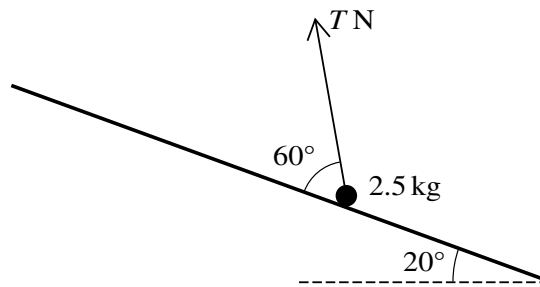

A particle of mass 2.5 kg is held in equilibrium on a rough plane inclined at 20° to the horizontal by a force of magnitude T N making an angle of 60° with a line of greatest slope of the plane (see diagram). The coefficient of friction between the particle and the plane is 0.3.

Find the greatest and least possible values of T .

[8]

32. [9709/w20/41/q7]

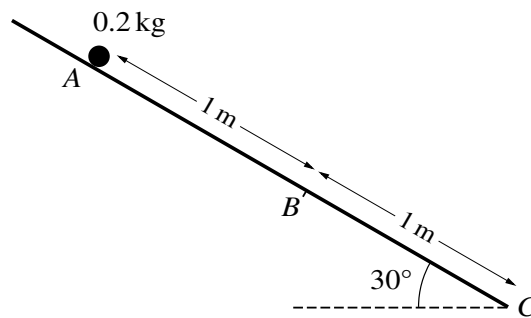

Three points A , B and C lie on a line of greatest slope of a plane inclined at an angle of 30° to the horizontal, with $AB = 1 \text{ m}$ and $BC = 1 \text{ m}$, as shown in the diagram. A particle of mass 0.2 kg is released from rest at A and slides down the plane. The part of the plane from A to B is smooth. The part of the plane from B to C is rough, with coefficient of friction μ between the plane and the particle.

- (a) Given that $\mu = \frac{1}{2}\sqrt{3}$, find the speed of the particle at C . [8]
- (b) Given instead that the particle comes to rest at C , find the exact value of μ . [4]

33. [9709/w20/42/q6]

A block of mass 5 kg is placed on a plane inclined at 30° to the horizontal. The coefficient of friction between the block and the plane is μ .

(a)

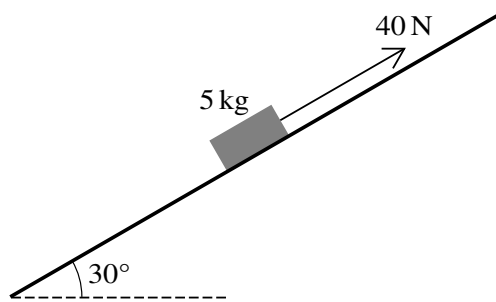

Fig. 6.1

When a force of magnitude 40 N is applied to the block, acting up the plane parallel to a line of greatest slope, the block begins to slide up the plane (see Fig. 6.1).

Show that $\mu < \frac{1}{5}\sqrt{3}$.

[4]

(b)

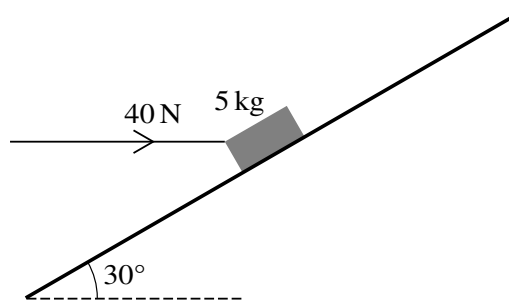

Fig. 6.2

When a force of magnitude 40 N is applied horizontally, in a vertical plane containing a line of greatest slope, the block does not move (see Fig. 6.2).

Show that, correct to 3 decimal places, the least possible value of μ is 0.152.

[4]

34. [9709/w20/43/q7]

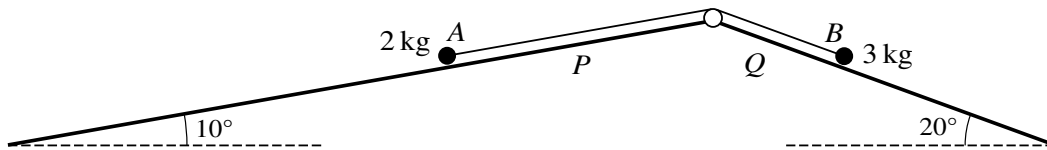

As shown in the diagram, particles A and B of masses 2 kg and 3 kg respectively are attached to the ends of a light inextensible string. The string passes over a small fixed smooth pulley which is attached to the top of two inclined planes. Particle A is on plane P , which is inclined at an angle of 10° to the horizontal. Particle B is on plane Q , which is inclined at an angle of 20° to the horizontal. The string is taut, and the two parts of the string are parallel to lines of greatest slope of their respective planes.

(a) It is given that plane P is smooth, plane Q is rough, and the particles are in limiting equilibrium.

Find the coefficient of friction between particle B and plane Q . [5]

(b) It is given instead that both planes are smooth and that the particles are released from rest at the same horizontal level.

Find the time taken until the difference in the vertical height of the particles is 1 m . [You should assume that this occurs before A reaches the pulley or B reaches the bottom of plane Q .] [6]

35. [9709/m19/42/q1]

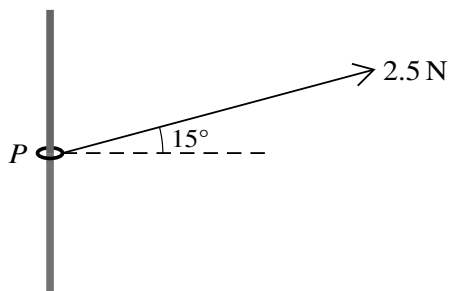

A small ring P of mass 0.03 kg is threaded on a rough vertical rod. A light inextensible string is attached to the ring and is pulled upwards at an angle of 15° to the horizontal. The tension in the string is 2.5 N (see diagram). The ring is in limiting equilibrium and on the point of sliding up the rod. Find the coefficient of friction between the ring and the rod. [4]

36. [9709/s19/41/q4]

A particle of mass 1.3 kg rests on a rough plane inclined at an angle θ to the horizontal, where $\tan \theta = \frac{12}{5}$. The coefficient of friction between the particle and the plane is μ .

- (i) A force of magnitude 20 N parallel to a line of greatest slope of the plane is applied to the particle and the particle is on the point of moving up the plane. Show that $\mu = 1.6$. [4]

The force of magnitude 20 N is now removed.

- (ii) Find the acceleration of the particle. [2]
- (iii) Find the work done against friction during the first 2 s of motion. [3]

37. [9709/w19/41/q3]

A block of mass 3 kg is at rest on a rough plane inclined at 60° to the horizontal. A force of magnitude 15 N acting up a line of greatest slope of the plane is just sufficient to prevent the block from sliding down the plane.

- (i) Find the coefficient of friction between the block and the plane. [5]

The force of magnitude 15 N is now replaced by a force of magnitude X N acting up the line of greatest slope.

- (ii) Find the greatest value of X for which the block does not move. [2]

38. [9709/w19/42/q6]

A block of mass 3 kg is initially at rest on a rough horizontal plane. A force of magnitude 6 N is applied to the block at an angle of θ above the horizontal, where $\cos \theta = \frac{24}{25}$. The force is applied for a period of 5 s, during which time the block moves a distance of 4.5 m.

- (i) Find the magnitude of the frictional force on the block. [4]
- (ii) Show that the coefficient of friction between the block and the plane is 0.165, correct to 3 significant figures. [3]
- (iii) When the block has moved a distance of 4.5 m, the force of magnitude 6 N is removed and the block then decelerates to rest. Find the total time for which the block is in motion. [4]

39. [9709/w19/43/q1]

A crate of mass 500 kg is being pulled along rough horizontal ground by a horizontal rope attached to a winch. The winch produces a constant pulling force of 2500 N and the crate is moving at constant speed. Find the coefficient of friction between the crate and the ground. [3]

40. [9709/m18/42/q4]

A particle of mass 12 kg is on a rough plane inclined at an angle of 25° to the horizontal. A force of magnitude P N acts on the particle. This force is horizontal and the particle is on the point of moving up a line of greatest slope of the plane. The coefficient of friction between the particle and the plane is 0.8. Find the value of P . [6]

41. [9709/s18/42/q5]

A particle of mass 20 kg is on a rough plane inclined at an angle of 60° to the horizontal. Equilibrium is maintained by a force of magnitude P N acting on the particle, in a direction parallel to a line of greatest slope of the plane. The greatest possible value of P is twice the least possible value of P . Find the value of the coefficient of friction between the particle and the plane. [7]

42. [9709/s18/43/q5]

A particle of mass 3 kg is on a rough plane inclined at an angle of 20° to the horizontal. A force of magnitude P N acting parallel to a line of greatest slope of the plane is used to keep the particle in equilibrium. The coefficient of friction between the particle and the plane is 0.35. Show that the least possible value of P is 0.394, correct to 3 significant figures, and find the greatest possible value of P . [6]

43. [9709/w18/42/q2]

A block of mass 5 kg is being pulled by a rope up a rough plane inclined at 6° to the horizontal. The rope is parallel to a line of greatest slope of the plane and the block is moving at constant speed. The coefficient of friction between the block and the plane is 0.3. Find the tension in the rope. [4]

44. [9709/w18/43/q2]

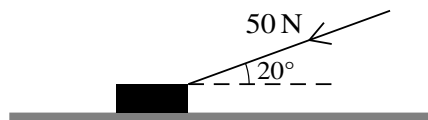

A block is pushed along a horizontal floor by a force of magnitude 50 N which acts at an angle of 20° to the horizontal (see diagram). The coefficient of friction between the block and the floor is 0.3. Given that the speed of the block is constant, find the mass of the block. [5]

45. [9709/m17/42/q3]

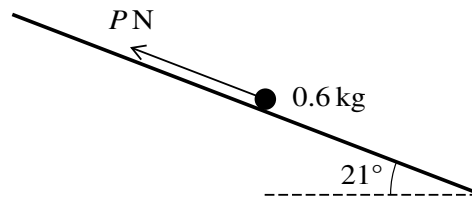

A particle of mass 0.6 kg is placed on a rough plane which is inclined at an angle of 21° to the horizontal. The particle is kept in equilibrium by a force of magnitude P N acting parallel to a line of greatest slope of the plane, as shown in the diagram. The coefficient of friction between the particle and the plane is 0.3. Show that the least possible value of P is 0.470, correct to 3 significant figures, and find the greatest possible value of P . [6]

46. [9709/s17/42/q5]

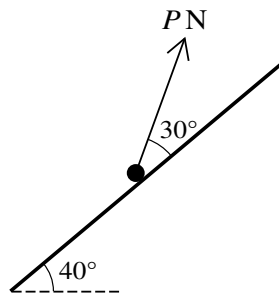

A particle of mass 0.12 kg is placed on a plane which is inclined at an angle of 40° to the horizontal. The particle is kept in equilibrium by a force of magnitude PN acting up the plane at an angle of 30° above a line of greatest slope, as shown in the diagram. The coefficient of friction between the particle and the plane is 0.32 . Find the set of possible values of P . [8]

47. [9709/w17/42/q1]

A particle of mass 0.2 kg is resting in equilibrium on a rough plane inclined at 20° to the horizontal.

(i) Show that the friction force acting on the particle is 0.684 N, correct to 3 significant figures. [1]

The coefficient of friction between the particle and the plane is 0.6. A force of magnitude 0.9 N is applied to the particle down a line of greatest slope of the plane. The particle accelerates down the plane.

(ii) Find this acceleration. [4]

48. [9709/w17/43/q7]

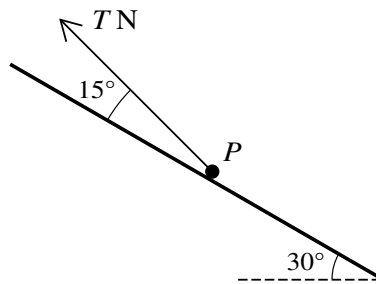

A particle P of mass 0.2 kg rests on a rough plane inclined at 30° to the horizontal. The coefficient of friction between the particle and the plane is 0.3 . A force of magnitude T N acts upwards on P at 15° above a line of greatest slope of the plane (see diagram).

(i) Find the least value of T for which the particle remains at rest. [6]

The force of magnitude T N is now removed. A new force of magnitude 0.25 N acts on P up the plane, parallel to a line of greatest slope of the plane. Starting from rest, P slides down the plane. After moving a distance of 3 m, P passes through the point A .

(ii) Use an energy method to find the speed of P at A . [5]

49. [9709/m16/42/q4]

A particle P of mass 0.8 kg is placed on a rough horizontal table. The coefficient of friction between P and the table is μ . A force of magnitude 5 N , acting upwards at an angle α above the horizontal, where $\tan \alpha = \frac{3}{4}$, is applied to P . The particle is on the point of sliding on the table.

(i) Find the value of μ . [4]

(ii) The magnitude of the force acting on P is increased to 10 N , with the direction of the force remaining the same. Find the acceleration of P . [3]

50. [9709/s16/42/q5]

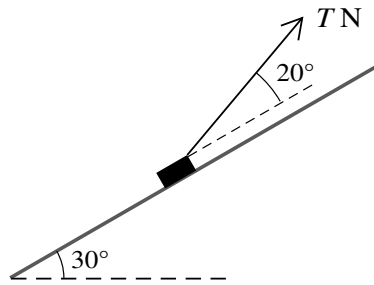

A block of mass 2.5 kg is placed on a plane which is inclined at an angle of 30° to the horizontal. The block is kept in equilibrium by a light string making an angle of 20° above a line of greatest slope. The tension in the string is T N, as shown in the diagram. The coefficient of friction between the block and plane is $\frac{1}{4}$. The block is in limiting equilibrium and is about to move up the plane. Find the value of T . [7]

51. [9709/s16/43/q4]

A particle of mass 15 kg is stationary on a rough plane inclined at an angle of 20° to the horizontal. The coefficient of friction between the particle and the plane is 0.2. A force of magnitude X N acting parallel to a line of greatest slope of the plane is used to keep the particle in equilibrium. Show that the least possible value of X is 23.1, correct to 3 significant figures, and find the greatest possible value of X . [7]

52. [9709/w16/41/q2]

A particle of mass 0.1 kg is released from rest on a rough plane inclined at 20° to the horizontal. It is given that, 5 seconds after release, the particle has a speed of 2 m s^{-1} .

- (i) Find the acceleration of the particle and hence show that the magnitude of the frictional force acting on the particle is 0.302 N, correct to 3 significant figures. [3]
- (ii) Find the coefficient of friction between the particle and the plane. [2]

53. [9709/w16/42/q1]

A particle of mass 2 kg is initially at rest on a rough horizontal plane. A force of magnitude 10 N is applied to the particle at 15° above the horizontal. It is given that 10 s after the force is applied, the particle has a speed of 3.5 m s^{-1} .

(i) Show that the magnitude of the frictional force is 8.96 N, correct to 3 significant figures. [3]

(ii) Find the coefficient of friction between the particle and the plane. [3]

54. [9709/w16/42/q5]

A particle of mass m kg is resting on a rough plane inclined at 30° to the horizontal. A force of magnitude 10 N applied to the particle up a line of greatest slope of the plane is just sufficient to stop the particle sliding down the plane. When a force of 75 N is applied to the particle up a line of greatest slope of the plane, the particle is on the point of sliding up the plane. Find m and the coefficient of friction between the particle and the plane. [6]

55. [9709/s15/42/q7]

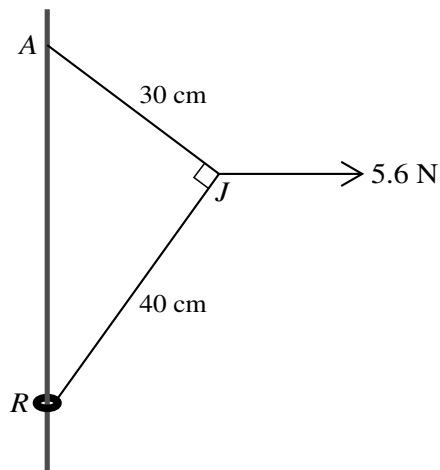

A small ring R is attached to one end of a light inextensible string of length 70 cm. A fixed rough vertical wire passes through the ring. The other end of the string is attached to a point A on the wire, vertically above R . A horizontal force of magnitude 5.6 N is applied to the point J of the string 30 cm from A and 40 cm from R . The system is in equilibrium with each of the parts AJ and JR of the string taut and angle AJR equal to 90° (see diagram).

(i) Find the tension in the part AJ of the string, and find the tension in the part JR of the string. [5]

The ring R has mass 0.2 kg and is in limiting equilibrium, on the point of moving up the wire.

(ii) Show that the coefficient of friction between R and the wire is 0.341, correct to 3 significant figures. [4]

A particle of mass m kg is attached to R and R is now in limiting equilibrium, on the point of moving down the wire.

(iii) Given that the coefficient of friction is unchanged, find the value of m . [3]

56. [9709/s15/43/q6]

A small box of mass 5 kg is pulled at a constant speed of 2.5 m s^{-1} down a line of greatest slope of a rough plane inclined at 10° to the horizontal. The pulling force has magnitude 20 N and acts downwards parallel to a line of greatest slope of the plane.

- (i) Find the coefficient of friction between the box and the plane. [5]

The pulling force is removed while the box is moving at 2.5 m s^{-1} .

- (ii) Find the distance moved by the box after the instant at which the pulling force is removed. [4]

57. [9709/w15/42/q6]

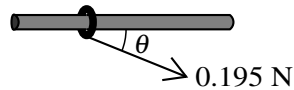

Fig. 1

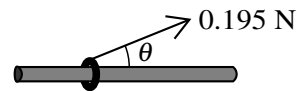

Fig. 2

A small ring of mass 0.024 kg is threaded on a fixed rough horizontal rod. A light inextensible string is attached to the ring and the string is pulled with a force of magnitude 0.195 N at an angle of θ with the horizontal, where $\sin \theta = \frac{5}{13}$. When the angle θ is below the horizontal (see Fig. 1) the ring is in limiting equilibrium.

- (i) Find the coefficient of friction between the ring and the rod. [6]

When the angle θ is above the horizontal (see Fig. 2) the ring moves.

- (ii) Find the acceleration of the ring. [4]

58. [9709/w15/43/q2]

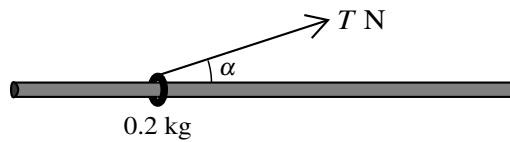

A ring of mass 0.2 kg is threaded on a fixed rough horizontal rod and a light inextensible string is attached to the ring at an angle α above the horizontal, where $\cos \alpha = 0.96$. The ring is in limiting equilibrium with the tension in the string T N (see diagram). Given that the coefficient of friction between the ring and the rod is 0.25, find the value of T . [5]

Chapter 6

Connected particles

1. [9709/m25/42/q4]

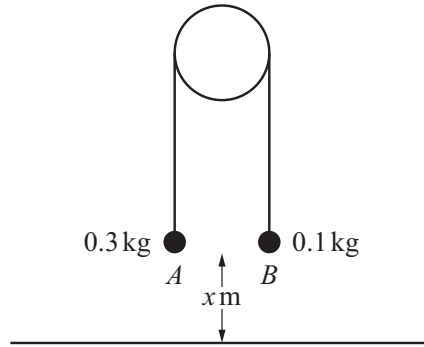

Two particles A and B have masses 0.3 kg and 0.1 kg respectively. The particles are attached to the ends of a light inextensible string. The string passes over a fixed smooth pulley, and the particles hang vertically below the pulley. Both particles are initially at a height of x m above horizontal ground (see diagram). The system is released from rest.

(a) Find the tension in the string and the acceleration of the particles. [4]

During the subsequent motion, B does **not** reach the pulley. When A reaches the ground, it comes to rest.

(b) Given that the greatest height of B above the ground is 1.2 m, find the value of x . [3]

2. [9709/s25/41/q6]

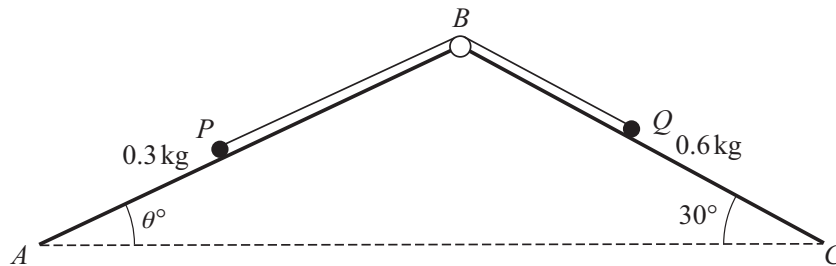

Two particles, P and Q , of masses 0.3 kg and 0.6 kg respectively, are attached to the ends of a light inextensible string. The string passes over a smooth pulley fixed at a point B where the inclined planes AB and BC meet. P lies on the smooth plane AB which is inclined at an angle θ° to the horizontal where $\sin \theta^\circ = 0.4$. Q lies on the plane BC which is inclined at 30° to the horizontal. The string is taut and the particles can move on lines of greatest slope of the two planes (see diagram). The particles are released from rest.

(a) It is given that the plane BC is smooth.

Find the tension in the string and the acceleration of Q . [5]

(b) It is given instead that the plane BC is rough. The work done against the frictional force when Q moves 2 m down the plane is 1.8 J. You should assume that P does **not** reach the pulley and that Q does **not** reach C .

Use an energy method to find the speed of Q when it has moved 2 m down the plane. [4]

3. [9709/s25/42/q5]

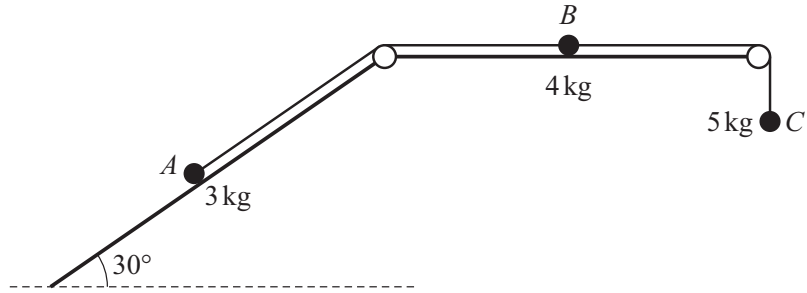

One end of a light inextensible string is attached to a particle A of mass 3 kg. The other end of the string is attached to a particle B of mass 4 kg. Particle A is in contact with a rough plane inclined at 30° to the horizontal, and particle B is in contact with a smooth horizontal plane. A second light inextensible string is attached to B . The other end of this second string is attached to a particle C of mass 5 kg which hangs vertically.

Both strings are taut and pass over small smooth pulleys that are fixed at the ends of the horizontal plane. The part of the string from A to the pulley is parallel to a line of greatest slope of the inclined plane, and A , B and C are in the same vertical plane (see diagram).

The system is released from rest. In the subsequent motion, C moves vertically downwards with acceleration 2 ms^{-2} , and neither A nor B reach a pulley.

- (a) Find the tensions in each of the strings. [3]
- (b) Find the coefficient of friction between A and the inclined plane. [4]

When the system has been in motion for 1.5 s, the string attached to A breaks.

- (c) Find the total distance that A travels up the plane from the instant that the system is released from rest to the instant that A comes to instantaneous rest. [5]

4. [9709/s25/43/q2]

A van of mass 4500 kg is towing a trailer of mass 350 kg along a straight horizontal road. The van and trailer are connected by a light rigid tow-bar which is parallel to the road. There are resistance forces of X N on the van and 120 N on the trailer. The driving force produced by the van's engine is 2500 N. The tension in the tow-bar is T N, and the acceleration of the van is 0.4 ms^{-2} .

Find the value of X and the value of T .

[4]

5. [9709/s25/43/q4]

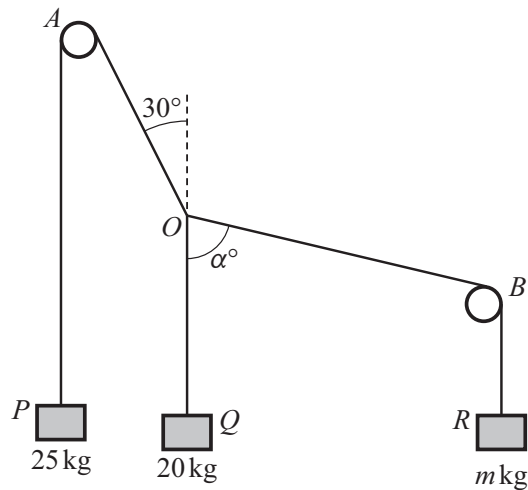

Three blocks P , Q and R , of masses 25 kg, 20 kg and m kg respectively, are held in equilibrium by three light inextensible strings OP , OQ and OR . The strings OP and OR both pass over small fixed smooth pulleys A and B respectively, with P and R hanging vertically below the pulleys. The block Q hangs vertically below the point O . The angle between OA and the vertical is 30° and the angle $BOQ = \alpha^\circ$ (see diagram).

Find the value of m and the value of α .

[6]

6. [9709/s25/45/q7]

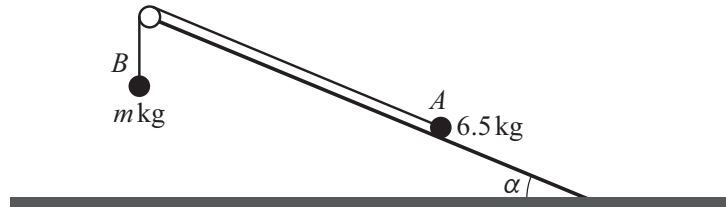

Two particles A and B of masses 6.5 kg and $m \text{ kg}$ respectively are connected by a light inextensible string that passes over a smooth pulley. The pulley is fixed at the top of a rough slope which is at an angle of α to the horizontal ground, where $\tan \alpha = \frac{5}{12}$. A is on the rough slope and B hangs below the pulley (see diagram). The coefficient of friction between the slope and A is 0.4 .

- (a) Given that the system is in equilibrium, find the set of possible values of m . [7]
- (b) It is given instead that $m = 12$ and the particles are released from rest with the string taut.

Use an energy method to find the speed of the particles when each particle has moved 0.6 m . You may assume that this occurs before A reaches the pulley or B reaches the ground. [5]

7. [9709/w25/41/q4]

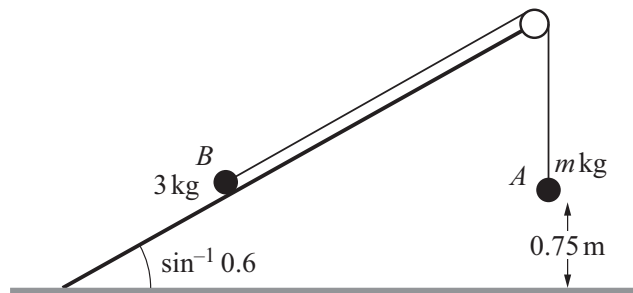

Two particles, A and B , of masses m kg and 3 kg respectively, are connected by a light inextensible string. Particle B is on a fixed plane which is at an angle of $\sin^{-1} 0.6$ to the horizontal ground. The string passes over a fixed smooth pulley at the top of the plane. Particle A hangs vertically below the pulley and is 0.75 m above the ground (see diagram).

The system is released from rest. In the subsequent motion B moves up a line of greatest slope of the plane and does not reach the pulley. As B moves up the plane there is a constant resistance to its motion of magnitude $\frac{10}{3}$ N. The speed of A immediately before it hits the ground is 2 m s⁻¹.

Use an energy method to find the value of m .

[6]

8. [9709/w25/42/q2]

A railway locomotive of mass 240 000 kg is towing a coach of mass 36 000 kg down a hill inclined at an angle of $\sin^{-1} 0.04$ to the horizontal. The driving force produced by the locomotive is 450 000 N and there are resistances to motion of 120 000 N on the locomotive and 15 000 N on the coach. The coupling between the locomotive and the coach is light, rigid and parallel to the hill.

Find the acceleration of the locomotive and the tension in the coupling.

[5]

9. [9709/w25/43/q5]

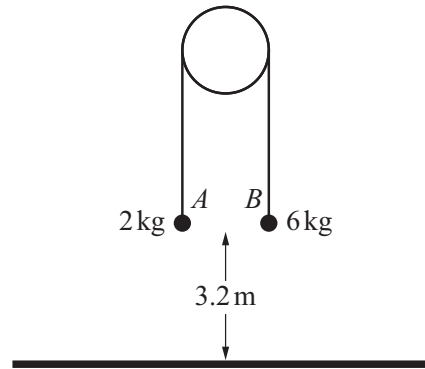

Particles A and B , of masses 2 kg and 6 kg respectively, are attached to the ends of a light inextensible string. The string passes over a smooth fixed pulley and the particles hang vertically below the pulley. Both particles are initially held at rest at a height of 3.2 m above horizontal ground (see diagram). Particle A is projected vertically **downwards** with a speed of 1.2 m s^{-1} .

(a) Find the tension in the string and the magnitude of the acceleration of the particles. [4]

In the subsequent motion, A does **not** hit the ground and neither particle reaches the pulley. When B hits the ground, it does **not** rebound.

(b) Find the time that B is in motion. [2]

(c) Find the distance between the lowest and highest points that A reaches. [4]

10. [9709/w25/45/q6]

Two particles A and B of masses km and m respectively, where k and m are constants, are free to move in a straight line on a smooth horizontal plane. Particle A is projected towards B with speed $2u$ and at the same instant B is projected towards A with speed u .

The particles collide. After the collision the speed of A is u and both particles move in the same direction as A 's original motion.

It is given that 35% of the total kinetic energy is lost in the collision. Find, in terms of u , the speed of B after the collision. [8]

11. [9709/s24/42/q7]

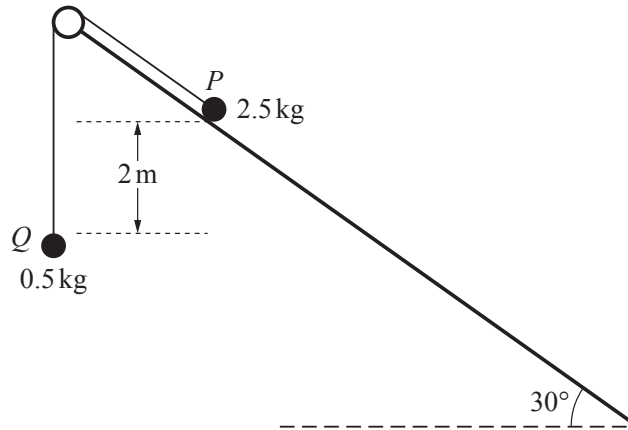

Two particles P and Q of masses 2.5 kg and 0.5 kg respectively are connected by a light inextensible string that passes over a small smooth pulley fixed at the top of a plane inclined at an angle of 30° to the horizontal. Particle P is on the plane and Q hangs below the pulley such that the level of Q is 2 m below the level of P (see diagram).

Particle P is released from rest with the string taut and slides down the plane. The plane is rough with coefficient of friction 0.2 between the plane and P .

- (a) Find the acceleration of P . [5]
- (b) Use an energy method to find the speed of the particles at the instant when they are at the same vertical height. [5]

12. [9709/s24/43/q5]

A van of mass 4500 kg is towing a trailer of mass 750 kg down a straight hill inclined at an angle of θ to the horizontal where $\sin \theta = 0.05$. The van and the trailer are connected by a light rigid tow-bar which is parallel to the road. There are constant resistance forces of 2500 N on the van and 300 N on the trailer.

(a) It is given that the tension in the tow-bar is 450 N.

Find the acceleration of the trailer and the driving force of the van's engine. [4]

On another occasion, the van and trailer ascend a straight hill inclined at an angle of α to the horizontal where $\sin \alpha = 0.09$. The driving force of the van's engine is now 9100 N, and the speed of the van at the bottom of the hill is 20 m s^{-1} . The resistances to motion are unchanged.

(b) (i) Find the acceleration of the van and the tension in the tow-bar. [5]

(ii) Find the speed of the van when it has travelled a distance of 375 m up the hill. [2]

13. [9709/w24/41/q1]

Two particles, of masses 1.8 kg and 1.2 kg, are connected by a light inextensible string that passes over a fixed smooth pulley. The particles hang vertically. The system is released from rest.

Find the magnitude of the acceleration of the particles and find the tension in the string. [4]

14. [9709/w24/42/q7]

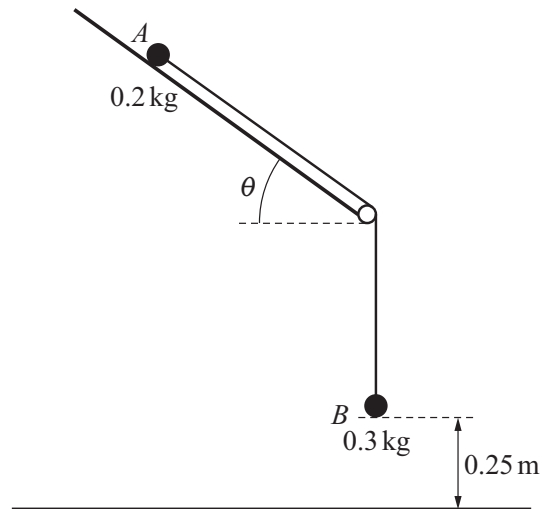

Two particles, A and B , of masses 0.2 kg and 0.3 kg respectively, are attached to the ends of a light inextensible string. The string passes over a small fixed smooth pulley which is attached to the bottom of a rough plane inclined at an angle θ to the horizontal where $\sin \theta = 0.6$. Particle A lies on the plane, and particle B hangs vertically below the pulley, 0.25 m above horizontal ground. The string between A and the pulley is parallel to a line of greatest slope of the plane (see diagram). The coefficient of friction between A and the plane is 1.125 . Particle A is released from rest.

- (a) Find the tension in the string and the magnitude of the acceleration of the particles. [7]
- (b) When B reaches the ground, it comes to rest.

Find the total distance that A travels down the plane from when it is released until it comes to rest. You may assume that A does not reach the pulley. [4]

15. [9709/w24/43/q7]

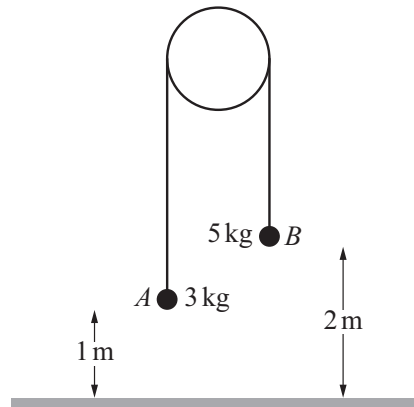

Two particles, A and B , of masses 3 kg and 5 kg respectively, are connected by a light inextensible string that passes over a fixed smooth pulley. The particles are held with the string taut and its straight parts vertical. Particle A is 1 m above a horizontal plane, and particle B is 2 m above the plane (see diagram).

The particles are released from rest. In the subsequent motion, A does not reach the pulley, and after B reaches the plane it remains in contact with the plane.

(a) Find the tension in the string and the time taken for B to reach the plane. [6]

(b) Find the time for which A is at least 3.25 m above the plane. [4]

16. [9709/m23/42/q4]

A toy railway locomotive of mass 0.8 kg is towing a truck of mass 0.4 kg on a straight horizontal track at a constant speed of 2 m s^{-1} . There is a constant resistance force of magnitude 0.2 N on the locomotive, but no resistance force on the truck. There is a light rigid horizontal coupling connecting the locomotive and the truck.

(a) State the tension in the coupling. [1]

(b) Find the power produced by the locomotive's engine. [1]

The power produced by the locomotive's engine is now changed to 1.2 W .

(c) Find the magnitude of the tension in the coupling at the instant that the locomotive begins to accelerate. [5]

17. [9709/s23/41/q6]

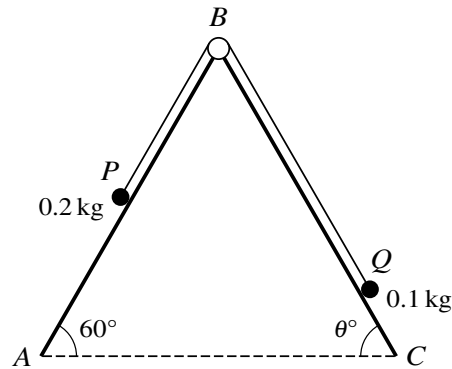

Two particles P and Q , of masses 0.2 kg and 0.1 kg respectively, are attached to the ends of a light inextensible string. The string passes over a fixed smooth pulley at B which is attached to two inclined planes. Particle P lies on a smooth plane AB which is inclined at 60° to the horizontal. Particle Q lies on a plane BC which is inclined at an angle of θ° to the horizontal. The string is taut and the particles can move on lines of greatest slope of the two planes (see diagram).

- (a) It is given that $\theta = 60$, the plane BC is rough and the coefficient of friction between Q and the plane BC is 0.7. The particles are released from rest.

Determine whether the particles move. [4]

- (b) It is given instead that the plane BC is smooth. The particles are released from rest and in the subsequent motion the tension in the string is $(\sqrt{3} - 1)$ N.

Find the magnitude of the acceleration of P as it moves on the plane, and find the value of θ . [4]

18. [9709/s23/42/q7]

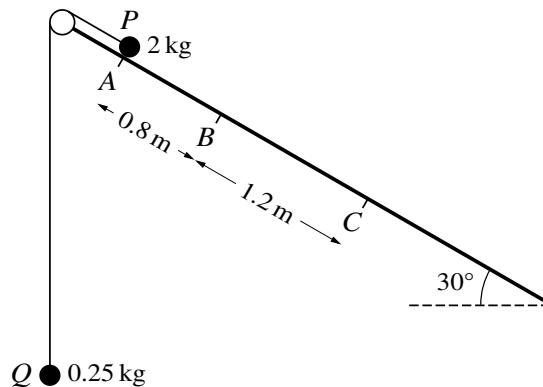

Two particles P and Q , of masses 2 kg and 0.25 kg respectively, are connected by a light inextensible string that passes over a fixed smooth pulley. Particle P is on an inclined plane at an angle of 30° to the horizontal. Particle Q hangs below the pulley. Three points A , B and C lie on a line of greatest slope of the plane with $AB = 0.8\text{ m}$ and $BC = 1.2\text{ m}$ (see diagram).

Particle P is released from rest at A with the string taut and slides down the plane. During the motion of P from A to C , Q does not reach the pulley. The part of the plane from A to B is rough, with coefficient of friction 0.3 between the plane and P . The part of the plane from B to C is smooth.

- (a) (i) Find the acceleration of P between A and B . [4]
(ii) Hence, find the speed of P at C . [5]
- (b) Find the time taken for P to travel from A to C . [4]

19. [9709/s23/43/q2]

A car of mass 1500 kg is towing a trailer of mass m kg along a straight horizontal road. The car and the trailer are connected by a tow-bar which is horizontal, light and rigid. There is a resistance force of F N on the car and a resistance force of 200 N on the trailer. The driving force of the car's engine is 3200 N, the acceleration of the car is 1.25 m s^{-2} and the tension in the tow-bar is 300 N.

Find the value of m and the value of F .

[4]

20. [9709/w23/41/q5]

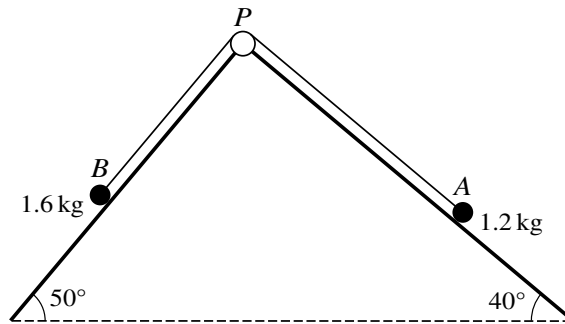

The diagram shows a particle A , of mass 1.2 kg , which lies on a plane inclined at an angle of 40° to the horizontal and a particle B , of mass 1.6 kg , which lies on a plane inclined at an angle of 50° to the horizontal. The particles are connected by a light inextensible string which passes over a small smooth pulley P fixed at the top of the planes. The parts AP and BP of the string are taut and parallel to lines of greatest slope of the respective planes. The two planes are rough, with the same coefficient of friction, μ , between the particles and the planes.

Find the value of μ for which the system is in limiting equilibrium.

[7]

21. [9709/w23/42/q6]

A railway engine of mass 120 000 kg is towing a coach of mass 60 000 kg up a straight track inclined at an angle of α to the horizontal where $\sin \alpha = 0.02$. There is a light rigid coupling, parallel to the track, connecting the engine and coach. The driving force produced by the engine is 125 000 N and there are constant resistances to motion of 22 000 N on the engine and 13 000 N on the coach.

(a) Find the acceleration of the engine and find the tension in the coupling. [5]

At an instant when the engine is travelling at 30 m s^{-1} , it comes to a section of track inclined upwards at an angle β to the horizontal. The power produced by the engine is now 4 500 000 W and, as a result, the engine maintains a constant speed.

(b) Assuming that the resistance forces remain unchanged, find the value of β . [4]

22. [9709/w23/43/q7]

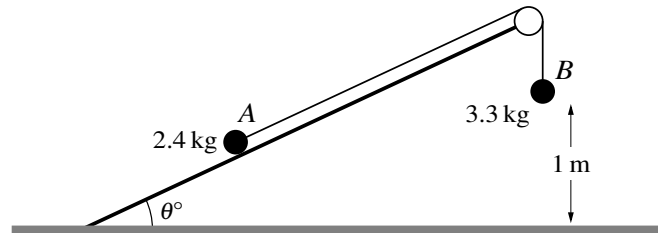

Particles A and B , of masses 2.4 kg and 3.3 kg respectively, are connected by a light inextensible string that passes over a smooth pulley which is fixed to the top of a rough plane. The plane makes an angle of θ° with horizontal ground. Particle A is on the plane and the section of the string between A and the pulley is parallel to a line of greatest slope of the plane. Particle B hangs vertically below the pulley and is 1 m above the ground (see diagram). The coefficient of friction between the plane and A is μ .

- (a) It is given that $\theta = 30$ and the system is in equilibrium with A on the point of moving directly up the plane.

Show that $\mu = 1.01$ correct to 3 significant figures. [5]

- (b) It is given instead that $\theta = 20$ and $\mu = 1.01$. The system is released from rest with the string taut.

Find the total distance travelled by A before coming to instantaneous rest. You may assume that A does not reach the pulley and that B remains at rest after it hits the ground. [8]

23. [9709/m22/42/q3]

A car of mass m kg is towing a trailer of mass 300 kg down a straight hill inclined at 3° to the horizontal at a constant speed. There are resistance forces on the car and on the trailer, and the total work done against the resistance forces in a distance of 50 m is 40 000 J. The engine of the car is doing no work and the tow-bar is light and rigid.

(a) Find the value of m . [3]

The resistance force on the trailer is 200 N.

(b) Find the tension in the tow-bar between the car and the trailer. [2]

24. [9709/s22/41/q2]

Two particles P and Q , of masses 0.5 kg and 0.3 kg respectively, are connected by a light inextensible string. The string is taut and P is vertically above Q . A force of magnitude 10 N is applied to P vertically upwards.

Find the acceleration of the particles and the tension in the string connecting them. [5]

25. [9709/s22/42/q3]

Two particles A and B , of masses 2.4 kg and 1.2 kg respectively, are connected by a light inextensible string which passes over a fixed smooth pulley. A is held at a distance of 2.1 m above a horizontal plane and B is 1.5 m above the plane. The particles hang vertically and are released from rest. In the subsequent motion A reaches the plane and does not rebound and B does not reach the pulley.

- (a) Show that the tension in the string before A reaches the plane is 16 N and find the magnitude of the acceleration of the particles before A reaches the plane. [4]
- (b) Find the greatest height of B above the plane. [3]

26. [9709/s22/43/q6]

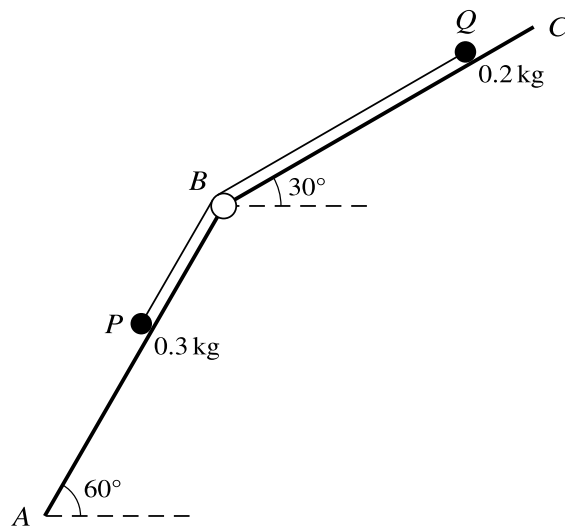

Two particles P and Q , of masses 0.3 kg and 0.2 kg respectively, are attached to the ends of a light inextensible string. The string passes over a fixed smooth pulley at B which is attached to two inclined planes. P lies on a smooth plane AB which is inclined at 60° to the horizontal. Q lies on a plane BC which is inclined at 30° to the horizontal. The string is taut and the particles can move on lines of greatest slope of the two planes (see diagram).

- (a) It is given that the plane BC is smooth and that the particles are released from rest.

Find the tension in the string and the magnitude of the acceleration of the particles. [5]

- (b) It is given instead that the plane BC is rough. A force of magnitude 3 N is applied to Q directly up the plane along a line of greatest slope of the plane.

Find the least value of the coefficient of friction between Q and the plane BC for which the particles remain at rest. [5]

27. [9709/w22/41/q6]

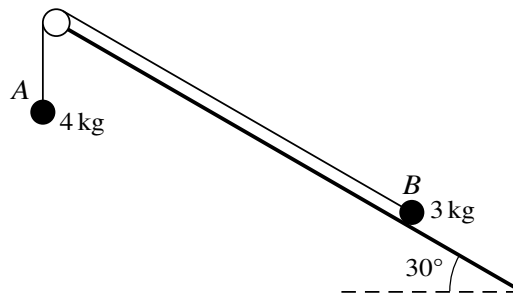

Fig. 6.1

Fig. 6.1 shows particles A and B , of masses 4 kg and 3 kg respectively, attached to the ends of a light inextensible string that passes over a small smooth pulley. The pulley is fixed at the top of a plane which is inclined at an angle of 30° to the horizontal. A hangs freely below the pulley and B is on the inclined plane. The string is taut and the section of the string between B and the pulley is parallel to a line of greatest slope of the plane.

(a) It is given that the plane is rough and the particles are in limiting equilibrium.

Find the coefficient of friction between B and the plane.

[6]

(b)

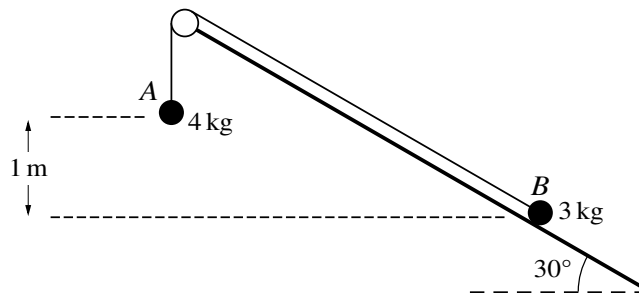

Fig. 6.2

It is given instead that the plane is smooth and the particles are released from rest when the difference in the vertical heights of the particles is 1 m (see Fig. 6.2).

Use an energy method to find the speed of the particles at the instant when the particles are at the same horizontal level.

[6]

28. [9709/w22/42/q5]

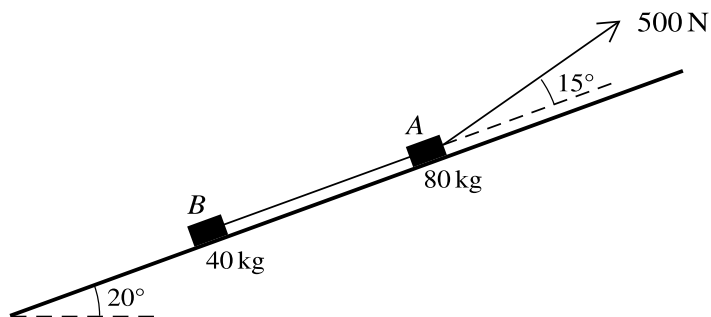

A block A of mass 80 kg is connected by a light, inextensible rope to a block B of mass 40 kg . The rope joining the two blocks is taut and is parallel to a line of greatest slope of a plane which is inclined at an angle of 20° to the horizontal. A force of magnitude 500 N inclined at an angle of 15° above the same line of greatest slope acts on A (see diagram). The blocks move up the plane and there is a resistance force of 50 N on B , but no resistance force on A .

(a) Find the acceleration of the blocks and the tension in the rope. [5]

(b) Find the time that it takes for the blocks to reach a speed of 1.2 m s^{-1} from rest. [2]

29. [9709/m21/42/q7]

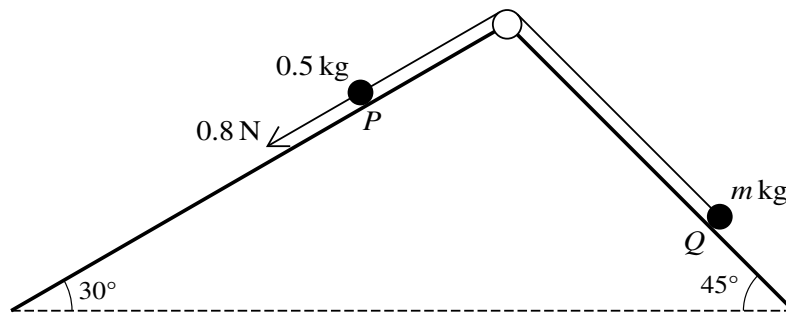

Two particles P and Q of masses 0.5 kg and $m \text{ kg}$ respectively are attached to the ends of a light inextensible string. The string passes over a fixed smooth pulley which is attached to the top of two inclined planes. The particles are initially at rest with P on a smooth plane inclined at 30° to the horizontal and Q on a plane inclined at 45° to the horizontal. The string is taut and the particles can move on lines of greatest slope of the two planes. A force of magnitude 0.8 N is applied to P acting down the plane, causing P to move down the plane (see diagram).

- (a) It is given that $m = 0.3$, and that the plane on which Q rests is smooth.

Find the tension in the string. [5]

- (b) It is given instead that the plane on which Q rests is rough, and that after each particle has moved a distance of 1 m , their speed is 0.6 m s^{-1} . The work done against friction in this part of the motion is 0.5 J .

Use an energy method to find the value of m . [5]

30. [9709/s21/41/q2]

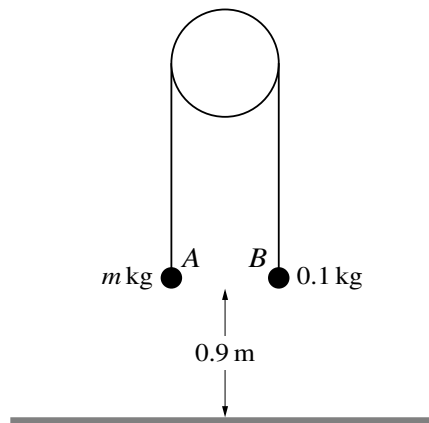

Two particles A and B have masses m kg and 0.1 kg respectively, where $m > 0.1$. The particles are attached to the ends of a light inextensible string. The string passes over a fixed smooth pulley and the particles hang vertically below it. Both particles are at a height of 0.9 m above horizontal ground (see diagram). The system is released from rest, and while both particles are in motion the tension in the string is 1.5 N. Particle B does not reach the pulley.

- (a) Find m . [4]
- (b) Find the speed at which A reaches the ground. [2]

31. [9709/s21/42/q5]

A car of mass 1250 kg is pulling a caravan of mass 800 kg along a straight road. The resistances to the motion of the car and caravan are 440 N and 280 N respectively. The car and caravan are connected by a light rigid tow-bar.

- (a) The car and caravan move along a horizontal part of the road at a constant speed of 30 m s^{-1} .
- (i) Calculate, in kW, the power developed by the engine of the car. [2]
 - (ii) Given that this power is suddenly decreased by 8 kW, find the instantaneous deceleration of the car and caravan and the tension in the tow-bar. [4]
- (b) The car and caravan now travel along a part of the road inclined at $\sin^{-1} 0.06$ to the horizontal. The car and caravan travel up the incline at constant speed with the engine of the car working at 28 kW.
- (i) Find this constant speed. [3]
 - (ii) Find the increase in the potential energy of the caravan in one minute. [2]

32. [9709/s21/43/q5]

A car of mass 1400 kg is towing a trailer of mass 500 kg down a straight hill inclined at an angle of 5° to the horizontal. The car and trailer are connected by a light rigid tow-bar. At the top of the hill the speed of the car and trailer is 20 m s^{-1} and at the bottom of the hill their speed is 30 m s^{-1} .

- (a) It is given that as the car and trailer descend the hill, the engine of the car does 150 000 J of work, and there are no resistance forces.

Find the length of the hill. [5]

- (b) It is given instead that there is a resistance force of 100 N on the trailer, the length of the hill is 200 m, and the acceleration of the car and trailer is constant.

Find the tension in the tow-bar between the car and trailer. [4]

33. [9709/w21/41/q7]

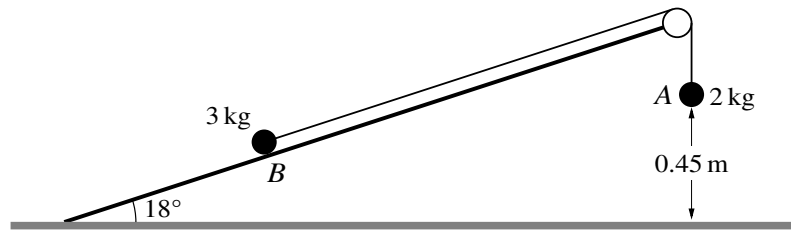

Two particles A and B of masses 2 kg and 3 kg respectively are connected by a light inextensible string. Particle B is on a smooth fixed plane which is at an angle of 18° to horizontal ground. The string passes over a fixed smooth pulley at the top of the plane. Particle A hangs vertically below the pulley and is 0.45 m above the ground (see diagram). The system is released from rest with the string taut. When A reaches the ground, the string breaks.

Find the total distance travelled by B before coming to instantaneous rest. You may assume that B does not reach the pulley. [8]

34. [9709/w21/42/q2]

A van of mass 3600 kg is towing a trailer of mass 1200 kg along a straight horizontal road using a light horizontal rope. There are resistance forces of 700 N on the van and 300 N on the trailer.

- (a) The driving force exerted by the van is 2500 N.

Find the tension in the rope. [4]

The driving force is now removed and the van driver applies a braking force which acts only on the van. The resistance forces remain unchanged.

- (b) Find the least possible value of the braking force which will cause the rope to become slack. [2]

35. [9709/w21/43/q6]

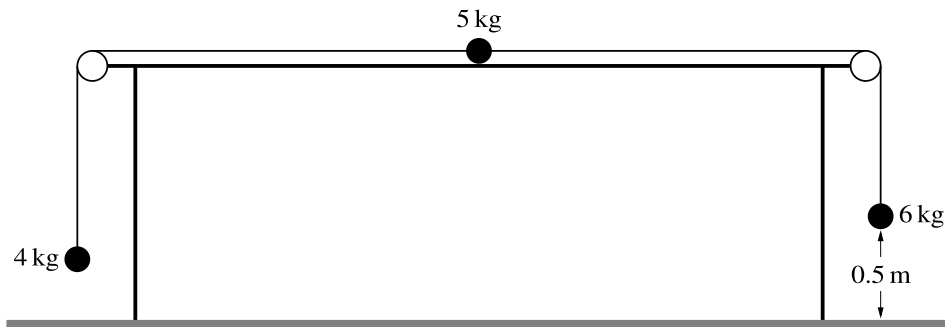

The diagram shows a particle of mass 5 kg on a rough horizontal table, and two light inextensible strings attached to it passing over smooth pulleys fixed at the edges of the table. Particles of masses 4 kg and 6 kg hang freely at the ends of the strings. The particle of mass 6 kg is 0.5 m above the ground. The system is in limiting equilibrium.

(a) Show that the coefficient of friction between the 5 kg particle and the table is 0.4. [2]

The 6 kg particle is now replaced by a particle of mass 8 kg and the system is released from rest.

(b) Find the acceleration of the 4 kg particle and the tensions in the strings. [5]

(c) In the subsequent motion the 8 kg particle hits the ground and does not rebound.

Find the time that elapses after the 8 kg particle hits the ground before the other two particles come to instantaneous rest. (You may assume this occurs before either particle reaches a pulley.) [5]

36. [9709/m20/42/q6]

On a straight horizontal test track, driverless vehicles (with no passengers) are being tested. A car of mass 1600 kg is towing a trailer of mass 700 kg along the track. The brakes are applied, resulting in a deceleration of 12 m s^{-2} . The braking force acts on the car only. In addition to the braking force there are constant resistance forces of 600 N on the car and of 200 N on the trailer.

(a) Find the magnitude of the force in the tow-bar. [2]

(b) Find the braking force. [2]

(c) At the instant when the brakes are applied, the car has speed 22 m s^{-1} . At this instant the car is 17.5 m away from a stationary van, which is directly in front of the car.

Show that the car hits the van at a speed of 8 m s^{-1} . [2]

(d) After the collision, the van starts to move with speed 5 m s^{-1} and the car and trailer continue moving in the same direction with speed 2 m s^{-1} .

Find the mass of the van. [3]

37. [9709/s20/41/q2]

A car of mass 1800 kg is towing a trailer of mass 400 kg along a straight horizontal road. The car and trailer are connected by a light rigid tow-bar. The car is accelerating at 1.5 m s^{-2} . There are constant resistance forces of 250 N on the car and 100 N on the trailer.

(a) Find the tension in the tow-bar. [2]

(b) Find the power of the engine of the car at the instant when the speed is 20 m s^{-1} . [3]

38. [9709/s20/43/q7]

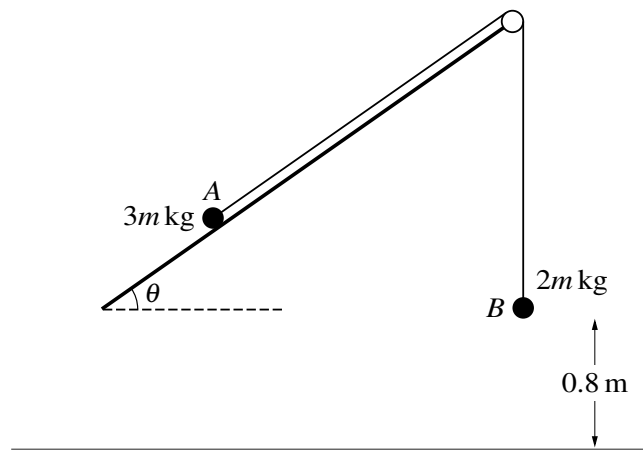

Two particles A and B , of masses $3m$ kg and $2m$ kg respectively, are attached to the ends of a light inextensible string. The string passes over a fixed smooth pulley which is attached to the edge of a plane. The plane is inclined at an angle θ to the horizontal. A lies on the plane and B hangs vertically, 0.8 m above the floor, which is horizontal. The string between A and the pulley is parallel to a line of greatest slope of the plane (see diagram). Initially A and B are at rest.

(a) Given that the plane is smooth, find the value of θ for which A remains at rest. [3]

It is given instead that the plane is rough, $\theta = 30^\circ$ and the acceleration of A up the plane is 0.1 m s^{-2} .

(b) Show that the coefficient of friction between A and the plane is $\frac{1}{10}\sqrt{3}$. [5]

(c) When B reaches the floor it comes to rest.

Find the length of time after B reaches the floor for which A is moving up the plane. [You may assume that A does not reach the pulley.] [4]

39. [9709/w20/41/q5]

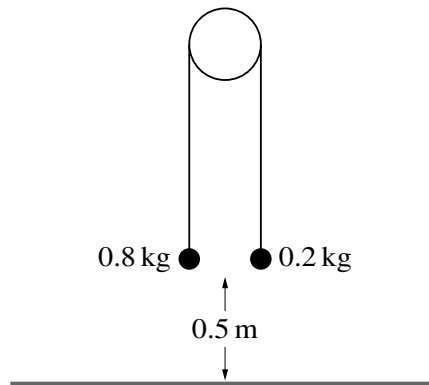

Two particles of masses 0.8 kg and 0.2 kg are connected by a light inextensible string that passes over a fixed smooth pulley. The system is released from rest with both particles 0.5 m above a horizontal floor (see diagram). In the subsequent motion the 0.2 kg particle does not reach the pulley.

- (a) Show that the magnitude of the acceleration of the particles is 6 m s^{-2} and find the tension in the string. [4]
- (b) When the 0.8 kg particle reaches the floor it comes to rest.

Find the greatest height of the 0.2 kg particle above the floor. [3]

40. [9709/w20/42/q8]

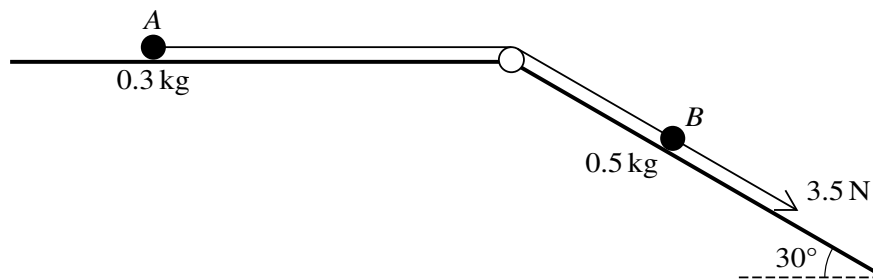

Two particles A and B , of masses 0.3 kg and 0.5 kg respectively, are attached to the ends of a light inextensible string. The string passes over a fixed smooth pulley which is attached to a horizontal plane and to the top of an inclined plane. The particles are initially at rest with A on the horizontal plane and B on the inclined plane, which makes an angle of 30° with the horizontal. The string is taut and B can move on a line of greatest slope of the inclined plane. A force of magnitude 3.5 N is applied to B acting down the plane (see diagram).

- (a) Given that both planes are smooth, find the tension in the string and the acceleration of B . [5]
- (b) It is given instead that the two planes are rough. When each particle has moved a distance of 0.6 m from rest, the total amount of work done against friction is 1.1 J .

Use an energy method to find the speed of B when it has moved this distance down the plane. [You should assume that the string is sufficiently long so that A does not hit the pulley when it moves 0.6 m .] [4]

41. [9709/w20/43/q6]

A car of mass 1600 kg is pulling a caravan of mass 800 kg. The car and the caravan are connected by a light rigid tow-bar. The resistances to the motion of the car and caravan are 400 N and 250 N respectively.

(a) The car and caravan are travelling along a straight horizontal road.

(i) Given that the car and caravan have a constant speed of 25 m s^{-1} , find the power of the car's engine. [2]

(ii) The engine's power is now suddenly increased to 39 kW. Find the instantaneous acceleration of the car and caravan and find the tension in the tow-bar. [5]

(b) The car and caravan now travel up a straight hill, inclined at an angle of $\sin^{-1} 0.05$ to the horizontal, at a constant speed of $v \text{ m s}^{-1}$. The car's engine is working at 32.5 kW.

Find v . [3]

42. [9709/w20/43/q7]

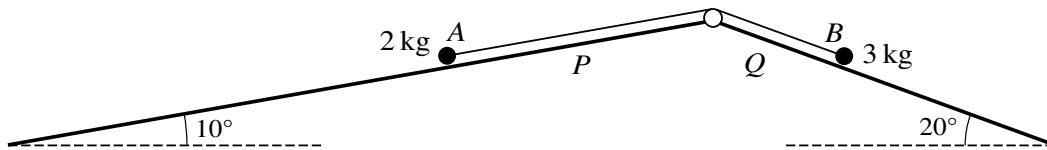

As shown in the diagram, particles A and B of masses 2 kg and 3 kg respectively are attached to the ends of a light inextensible string. The string passes over a small fixed smooth pulley which is attached to the top of two inclined planes. Particle A is on plane P , which is inclined at an angle of 10° to the horizontal. Particle B is on plane Q , which is inclined at an angle of 20° to the horizontal. The string is taut, and the two parts of the string are parallel to lines of greatest slope of their respective planes.

(a) It is given that plane P is smooth, plane Q is rough, and the particles are in limiting equilibrium.

Find the coefficient of friction between particle B and plane Q . [5]

(b) It is given instead that both planes are smooth and that the particles are released from rest at the same horizontal level.

Find the time taken until the difference in the vertical height of the particles is 1 m . [You should assume that this occurs before A reaches the pulley or B reaches the bottom of plane Q .] [6]

43. [9709/s19/41/q6]

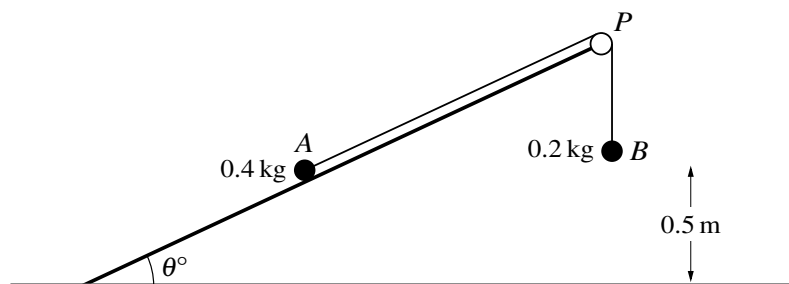

Two particles A and B , of masses 0.4 kg and 0.2 kg respectively, are connected by a light inextensible string. Particle A is held on a smooth plane inclined at an angle of θ° to the horizontal. The string passes over a small smooth pulley P fixed at the top of the plane, and B hangs freely 0.5 m above horizontal ground (see diagram). The particles are released from rest with both sections of the string taut.

- (i) Given that the system is in equilibrium, find θ . [3]
- (ii) It is given instead that $\theta = 20$. In the subsequent motion particle A does not reach P and B remains at rest after reaching the ground.
- (a) Find the tension in the string and the acceleration of the system. [4]
- (b) Find the speed of A at the instant B reaches the ground. [2]

44. [9709/s19/42/q5]

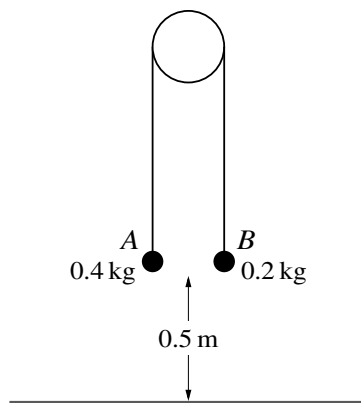

Two particles A and B , of masses 0.4 kg and 0.2 kg respectively, are connected by a light inextensible string which passes over a fixed smooth pulley. Both A and B are 0.5 m above the ground. The particles hang vertically (see diagram). The particles are released from rest. In the subsequent motion B does not reach the pulley and A remains at rest after reaching the ground.

- (i) For the motion before A reaches the ground, show that the magnitude of the acceleration of each particle is $\frac{10}{3} \text{ m s}^{-2}$ and find the tension in the string. [4]
- (ii) Find the maximum height of B above the ground. [4]

45. [9709/s19/43/q4]

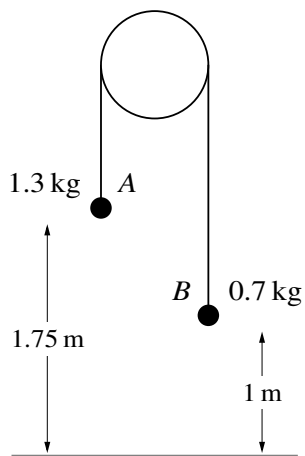

Two particles A and B , of masses 1.3 kg and 0.7 kg respectively, are connected by a light inextensible string which passes over a smooth fixed pulley. Particle A is 1.75 m above the floor and particle B is 1 m above the floor (see diagram). The system is released from rest with the string taut, and the particles move vertically. When the particles are at the same height the string breaks.

- (i) Show that, before the string breaks, the magnitude of the acceleration of each particle is 3 m s^{-2} and find the tension in the string. [4]
- (ii) Find the difference in the times that it takes the particles to hit the ground. [6]

46. [9709/w19/41/q4]

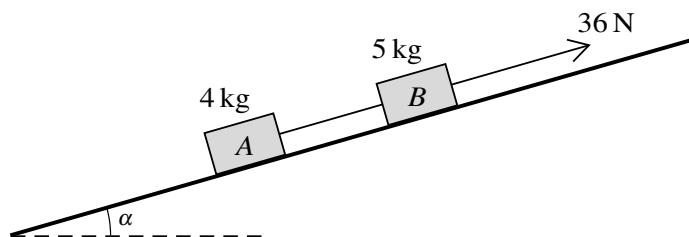

Two blocks A and B of masses 4 kg and 5 kg respectively are joined by a light inextensible string. The blocks rest on a smooth plane inclined at an angle α to the horizontal, where $\tan \alpha = \frac{7}{24}$. The string is parallel to a line of greatest slope of the plane with B above A . A force of magnitude 36 N acts on B , parallel to a line of greatest slope of the plane (see diagram).

- (i) Find the acceleration of the blocks and the tension in the string. [5]
- (ii) At a particular instant, the speed of the blocks is 1 m s^{-1} . Find the time, after this instant, that it takes for the blocks to travel 0.65 m. [2]

47. [9709/w19/42/q7]

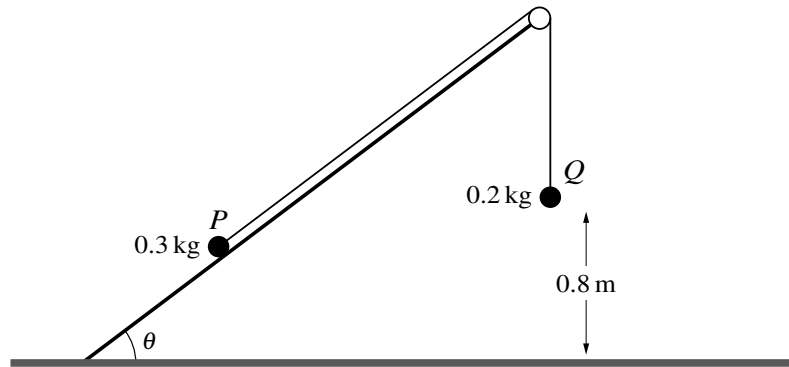

Two particles P and Q , of masses 0.3 kg and 0.2 kg respectively, are attached to the ends of a light inextensible string. The string passes over a fixed smooth pulley which is attached to the edge of a smooth plane. The plane is inclined at an angle θ to the horizontal, where $\sin \theta = \frac{3}{5}$. P lies on the plane and Q hangs vertically below the pulley at a height of 0.8 m above the floor (see diagram). The string between P and the pulley is parallel to a line of greatest slope of the plane. P is released from rest and Q moves vertically downwards.

(i) Find the tension in the string and the magnitude of the acceleration of the particles. [5]

Q hits the floor and does not bounce. It is given that P does not reach the pulley in the subsequent motion.

(ii) Find the time, from the instant at which P is released, for Q to reach the floor. [2]

(iii) When Q hits the floor the string becomes slack. Find the time, from the instant at which P is released, for the string to become taut again. [4]

48. [9709/w19/43/q7]

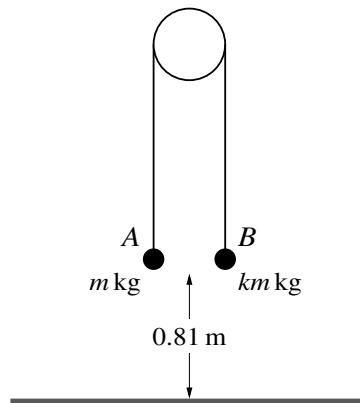

Two particles A and B have masses m kg and km kg respectively, where $k > 1$. The particles are attached to the ends of a light inextensible string. The string passes over a fixed smooth pulley and the particles hang vertically below it. Both particles are at a height of 0.81 m above horizontal ground (see diagram). The system is released from rest and particle B reaches the ground 0.9 s later. The particle A does not reach the pulley in its subsequent motion.

- (i) Find the value of k and show that the tension in the string before B reaches the ground is equal to $12m$ N. [7]

At the instant when B reaches the ground, the string breaks.

- (ii) Show that the speed of A when it reaches the ground is 5.97 m s⁻¹, correct to 3 significant figures, and find the time taken, after the string breaks, for A to reach the ground. [4]
- (iii) Sketch a velocity-time graph for the motion of particle A from the instant when the system is released until A reaches the ground. [2]

49. [9709/s18/41/q7]

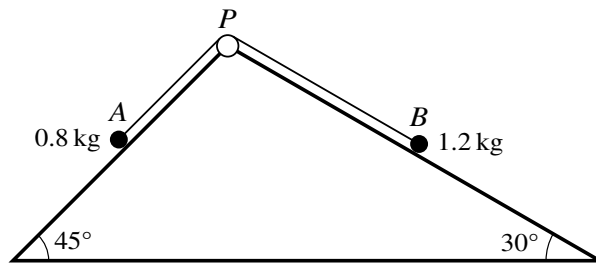

The diagram shows a triangular block with sloping faces inclined to the horizontal at 45° and 30° . Particle A of mass 0.8 kg lies on the face inclined at 45° and particle B of mass 1.2 kg lies on the face inclined at 30° . The particles are connected by a light inextensible string which passes over a small smooth pulley P fixed at the top of the faces. The parts AP and BP of the string are parallel to lines of greatest slope of the respective faces. The particles are released from rest with both parts of the string taut. In the subsequent motion neither particle reaches the pulley and neither particle reaches the bottom of a face.

- (i) Given that both faces are smooth, find the speed of A after each particle has travelled a distance of 0.4 m . [6]
- (ii) It is given instead that both faces are rough. The coefficient of friction between each particle and a face of the block is μ . Find the value of μ for which the system is in limiting equilibrium. [6]

50. [9709/s18/42/q7]

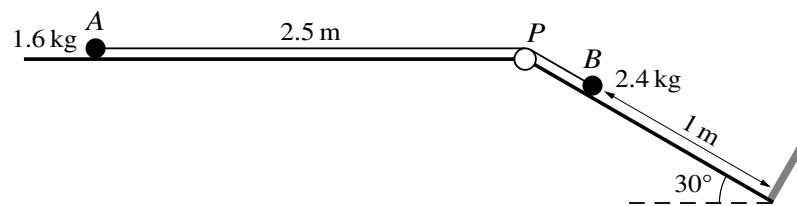

As shown in the diagram, a particle A of mass 1.6 kg lies on a horizontal plane and a particle B of mass 2.4 kg lies on a plane inclined at an angle of 30° to the horizontal. The particles are connected by a light inextensible string which passes over a small smooth pulley P fixed at the top of the inclined plane. The distance AP is 2.5 m and the distance of B from the bottom of the inclined plane is 1 m. There is a barrier at the bottom of the inclined plane preventing any further motion of B . The part BP of the string is parallel to a line of greatest slope of the inclined plane. The particles are released from rest with both parts of the string taut.

- (i) Given that both planes are smooth, find the acceleration of A and the tension in the string. [5]
- (ii) It is given instead that the horizontal plane is rough and that the coefficient of friction between A and the horizontal plane is 0.2. The inclined plane is smooth. Find the total distance travelled by A . [9]

51. [9709/s18/43/q4]

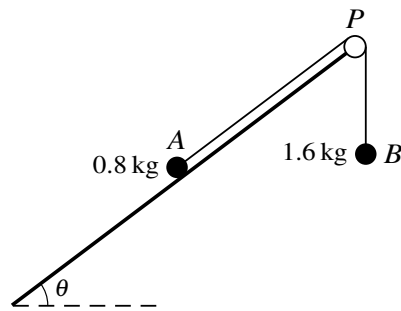

Two particles A and B , of masses 0.8 kg and 1.6 kg respectively, are connected by a light inextensible string. Particle A is placed on a smooth plane inclined at an angle θ to the horizontal, where $\sin \theta = \frac{3}{5}$. The string passes over a small smooth pulley P fixed at the top of the plane, and B hangs freely (see diagram). The section AP of the string is parallel to a line of greatest slope of the plane. The particles are released from rest with both sections of the string taut. Use an energy method to find the speed of the particles after each particle has moved a distance of 0.5 m , assuming that A has not yet reached the pulley. [6]

52. [9709/w18/41/q4]

Two particles A and B , of masses m kg and 0.3 kg respectively, are attached to the ends of a light inextensible string. The string passes over a fixed smooth pulley and the particles hang freely below it. The system is released from rest, with both particles 0.8 m above horizontal ground. Particle A reaches the ground with a speed of 0.6 m s⁻¹.

(i) Find the tension in the string during the motion before A reaches the ground. [4]

(ii) Find the value of m . [2]

53. [9709/w18/42/q4]

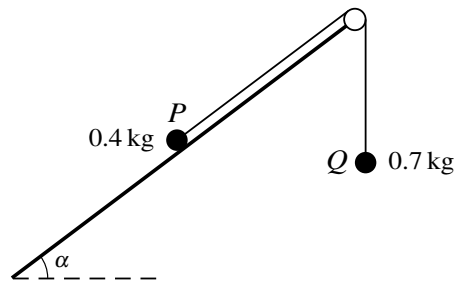

Two particles P and Q , of masses 0.4 kg and 0.7 kg respectively, are attached to the ends of a light inextensible string. The string passes over a fixed smooth pulley which is attached to the edge of a rough plane. The coefficient of friction between P and the plane is 0.5. The plane is inclined at an angle α to the horizontal, where $\tan \alpha = \frac{3}{4}$. Particle P lies on the plane and particle Q hangs vertically. The string between P and the pulley is parallel to a line of greatest slope of the plane (see diagram). A force of magnitude X N, acting directly down the plane, is applied to P .

(i) Show that the greatest value of X for which P remains stationary is 6.2. [4]

(ii) Given instead that $X = 0.8$, find the acceleration of P . [4]

54. [9709/w18/43/q5]

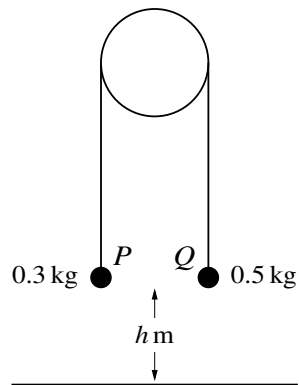

Two particles P and Q , of masses 0.3 kg and 0.5 kg respectively, are attached to the ends of a light inextensible string. The string passes over a fixed smooth pulley with the particles hanging freely below it. Q is held at rest with the string taut at a height of h m above a horizontal floor (see diagram). Q is now released and both particles start to move. The pulley is sufficiently high so that P does not reach it at any stage. The time taken for Q to reach the floor is 0.6 s.

(i) Find the acceleration of Q before it reaches the floor and hence find the value of h . [6]

Q remains at rest when it reaches the floor, and P continues to move upwards.

(ii) Find the velocity of P at the instant when Q reaches the floor and the total time taken from the instant at which Q is released until the string becomes taut again. [3]

55. [9709/m17/42/q6]

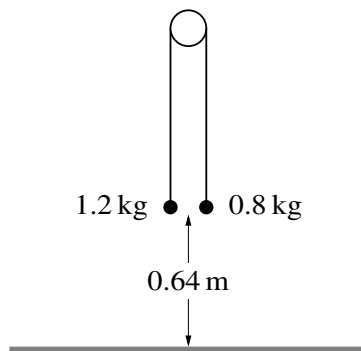

Two particles of masses 1.2 kg and 0.8 kg are connected by a light inextensible string that passes over a fixed smooth pulley. The particles hang vertically. The system is released from rest with both particles 0.64 m above the floor (see diagram). In the subsequent motion the 0.8 kg particle does not reach the pulley.

- (i) Show that the acceleration of the particles is 2 m s^{-2} and find the tension in the string. [4]
- (ii) Find the total distance travelled by the 0.8 kg particle during the first second after the particles are released. [8]

56. [9709/s17/41/q7]

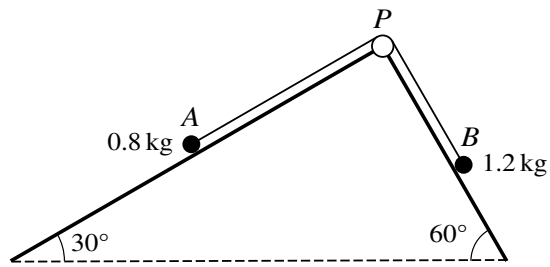

As shown in the diagram, a particle A of mass 0.8 kg lies on a plane inclined at an angle of 30° to the horizontal and a particle B of mass 1.2 kg lies on a plane inclined at an angle of 60° to the horizontal. The particles are connected by a light inextensible string which passes over a small smooth pulley P fixed at the top of the planes. The parts AP and BP of the string are parallel to lines of greatest slope of the respective planes. The particles are released from rest with both parts of the string taut.

- (i) Given that both planes are smooth, find the acceleration of A and the tension in the string. [6]
- (ii) It is given instead that both planes are rough, with the same coefficient of friction, μ , for both particles. Find the value of μ for which the system is in limiting equilibrium. [6]

57. [9709/s17/42/q6]

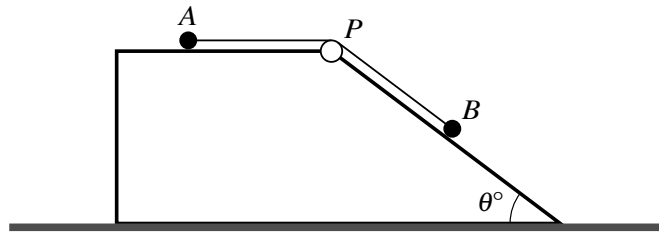

The diagram shows a fixed block with a horizontal top surface and a surface which is inclined at an angle of θ° to the horizontal, where $\sin \theta = \frac{3}{5}$. A particle A of mass 0.3 kg rests on the horizontal surface and is attached to one end of a light inextensible string. The string passes over a small smooth pulley P fixed at the edge of the block. The other end of the string is attached to a particle B of mass 1.5 kg which rests on the sloping surface of the block. The system is released from rest with the string taut.

- (i) Given that the block is smooth, find the acceleration of particle A and the tension in the string. [5]
- (ii) It is given instead that the block is rough. The coefficient of friction between A and the block is μ and the coefficient of friction between B and the block is also μ . In the first 3 seconds of the motion, A does not reach P and B does not reach the bottom of the sloping surface. The speed of the particles after 3 s is 5 m s^{-1} . Find the acceleration of particle A and the value of μ . [9]

58. [9709/s17/43/q7]

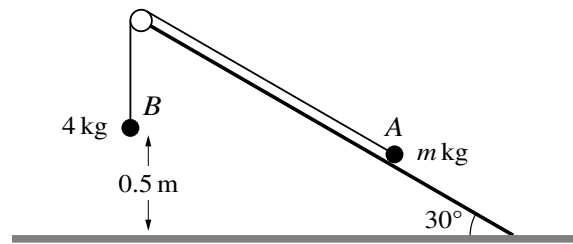

Two particles A and B of masses m kg and 4 kg respectively are connected by a light inextensible string that passes over a fixed smooth pulley. Particle A is on a rough fixed slope which is at an angle of 30° to the horizontal ground. Particle B hangs vertically below the pulley and is 0.5 m above the ground (see diagram). The coefficient of friction between the slope and particle A is 0.2 .

- (i) In the case where the system is in equilibrium with particle A on the point of moving directly up the slope, show that $m = 5.94$, correct to 3 significant figures. [6]
- (ii) In the case where $m = 3$, the system is released from rest with the string taut. Find the total distance travelled by A before coming to instantaneous rest. You may assume that A does not reach the pulley. [8]

59. [9709/w17/41/q7]

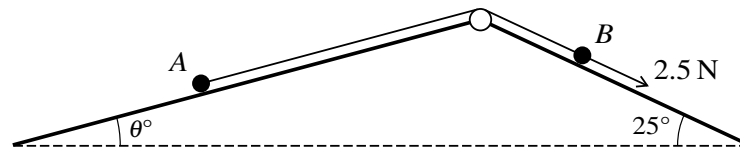

Two particles A and B of masses 0.9 kg and 0.4 kg respectively are attached to the ends of a light inextensible string. The string passes over a fixed smooth pulley which is attached to the top of two inclined planes. The particles are initially at rest with A on a smooth plane inclined at angle θ° to the horizontal and B on a plane inclined at angle 25° to the horizontal. The string is taut and the particles can move on lines of greatest slope of the two planes. A force of magnitude 2.5 N is applied to B acting down the plane (see diagram).

- (i) For the case where $\theta = 15$ and the plane on which B rests is smooth, find the acceleration of B . [5]
- (ii) For a different value of θ , the plane on which B rests is rough with coefficient of friction between the plane and B of 0.8. The system is in limiting equilibrium with B on the point of moving in the direction of the 2.5 N force. Find the value of θ . [5]

60. [9709/w17/42/q6]

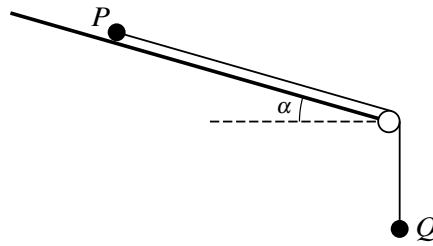

Two particles P and Q , each of mass m kg, are attached to the ends of a light inextensible string. The string passes over a fixed smooth pulley which is attached to the edge of a rough plane. The plane is inclined at an angle α to the horizontal, where $\tan \alpha = \frac{7}{24}$. Particle P rests on the plane and particle Q hangs vertically, as shown in the diagram. The string between P and the pulley is parallel to a line of greatest slope of the plane. The system is in limiting equilibrium.

(i) Show that the coefficient of friction between P and the plane is $\frac{4}{3}$. [5]

A force of magnitude 10 N is applied to P , acting up a line of greatest slope of the plane, and P accelerates at 2.5 m s^{-2} .

(ii) Find the value of m . [5]

61. [9709/w17/43/q4]

Two particles A and B have masses 0.35 kg and 0.45 kg respectively. The particles are attached to the ends of a light inextensible string which passes over a small fixed smooth pulley which is 1 m above horizontal ground. Initially particle A is held at rest on the ground vertically below the pulley, with the string taut. Particle B hangs vertically below the pulley at a height of 0.64 m above the ground. Particle A is released.

- (i) Find the speed of A at the instant that B reaches the ground. [5]
- (ii) Assuming that B does not bounce after it reaches the ground, find the total distance travelled by A between the instant that B reaches the ground and the instant when the string becomes taut again. [2]

62. [9709/m16/42/q5]

A car of mass 1200 kg is pulling a trailer of mass 800 kg up a hill inclined at an angle α to the horizontal, where $\sin \alpha = 0.1$. The system of the car and the trailer is modelled as two particles connected by a light inextensible cable. The driving force of the car's engine is 2500 N and the resistances to the car and trailer are 100 N and 150 N respectively.

(i) Find the acceleration of the system and the tension in the cable. [4]

(ii) When the car and trailer are travelling at a speed of 30 m s^{-1} , the driving force becomes zero. The cable remains taut. Find the time, in seconds, before the system comes to rest. [3]

63. [9709/m16/42/q6]

Two particles A and B , of masses 0.8 kg and 0.2 kg respectively, are connected by a light inextensible string. Particle A is placed on a horizontal surface. The string passes over a small smooth pulley P fixed at the edge of the surface, and B hangs freely. The horizontal section of the string, AP , is of length 2.5 m. The particles are released from rest with both sections of the string taut.

- (i) Given that the surface is smooth, find the time taken for A to reach the pulley. [5]
- (ii) Given instead that the surface is rough and the coefficient of friction between A and the surface is 0.1 , find the speed of A immediately before it reaches the pulley. [5]

64. [9709/s16/41/q5]

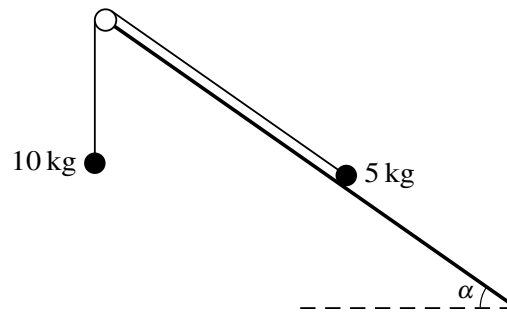

Two particles of masses 5 kg and 10 kg are connected by a light inextensible string that passes over a fixed smooth pulley. The 5 kg particle is on a rough fixed slope which is at an angle of α to the horizontal, where $\tan \alpha = \frac{3}{4}$. The 10 kg particle hangs below the pulley (see diagram). The coefficient of friction between the slope and the 5 kg particle is $\frac{1}{2}$. The particles are released from rest. Find the acceleration of the particles and the tension in the string. [7]

65. [9709/s16/42/q7]

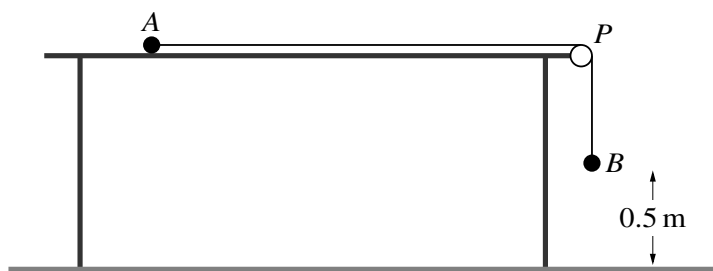

A particle A of mass 1.6 kg rests on a horizontal table and is attached to one end of a light inextensible string. The string passes over a small smooth pulley P fixed at the edge of the table. The other end of the string is attached to a particle B of mass 2.4 kg which hangs freely below the pulley. The system is released from rest with the string taut and with B at a height of 0.5 m above the ground, as shown in the diagram. In the subsequent motion A does not reach P before B reaches the ground.

- (i) Given that the table is smooth, find the time taken by B to reach the ground. [5]
- (ii) Given instead that the table is rough and that the coefficient of friction between A and the table is $\frac{3}{8}$, find the total distance travelled by A . You may assume that A does not reach the pulley. [7]

66. [9709/s16/43/q6]

Two particles of masses 1.3 kg and 0.7 kg are connected by a light inextensible string that passes over a fixed smooth pulley. The particles are held at the same vertical height with the string taut. The distance of each particle above a horizontal plane is 2 m, and the distance of each particle below the pulley is 4 m. The particles are released from rest.

(i) Find

(a) the tension in the string before the particle of mass 1.3 kg reaches the plane,

(b) the time taken for the particle of mass 1.3 kg to reach the plane.

[6]

(ii) Find the greatest height of the particle of mass 0.7 kg above the plane.

[4]

67. [9709/w16/41/q1]



Two particles P and Q , of masses 0.6 kg and 0.4 kg respectively, are connected by a light inextensible string. The string passes over a small smooth light pulley fixed at the edge of a smooth horizontal table. Initially P is held at rest on the table and Q hangs vertically (see diagram). P is then released. Find the tension in the string and the acceleration of Q . [4]

68. [9709/w16/43/q3]

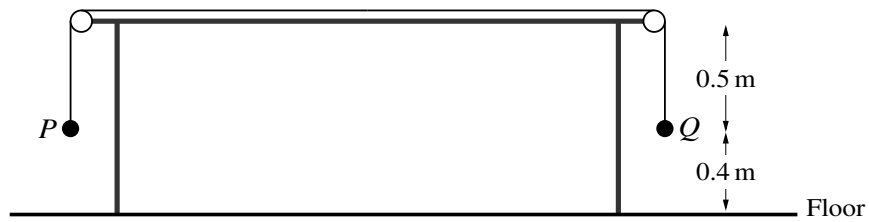

Particles P and Q , of masses 7 kg and 3 kg respectively, are attached to the two ends of a light inextensible string. The string passes over two small smooth pulleys attached to the two ends of a horizontal table. The two particles hang vertically below the two pulleys. The two particles are both initially at rest, 0.5 m below the level of the table, and 0.4 m above the horizontal floor (see diagram).

- (i) Find the acceleration of the particles and the speed of P immediately before it reaches the floor. [4]
- (ii) Determine whether Q comes to instantaneous rest before it reaches the pulley directly above it. [2]

69. [9709/s15/41/q7]

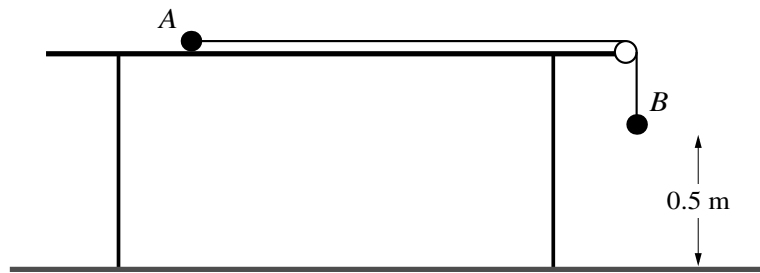

Particles A and B , of masses 0.3 kg and 0.7 kg respectively, are attached to the ends of a light inextensible string. Particle A is held at rest on a rough horizontal table with the string passing over a smooth pulley fixed at the edge of the table. The coefficient of friction between A and the table is 0.2 . Particle B hangs vertically below the pulley at a height of 0.5 m above the floor (see diagram). The system is released from rest and 0.25 s later the string breaks. A does not reach the pulley in the subsequent motion. Find

- (i) the speed of B immediately before it hits the floor, [9]
- (ii) the total distance travelled by A . [3]

70. [9709/s15/42/q6]

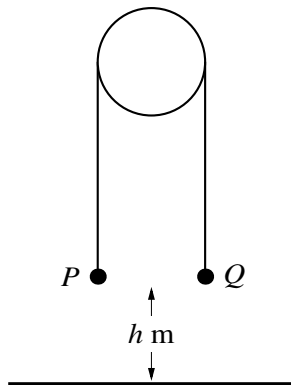

Fig. 1

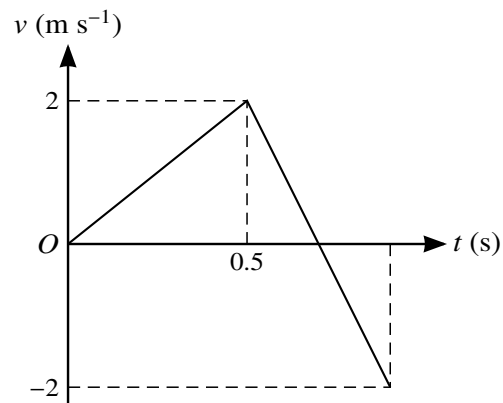
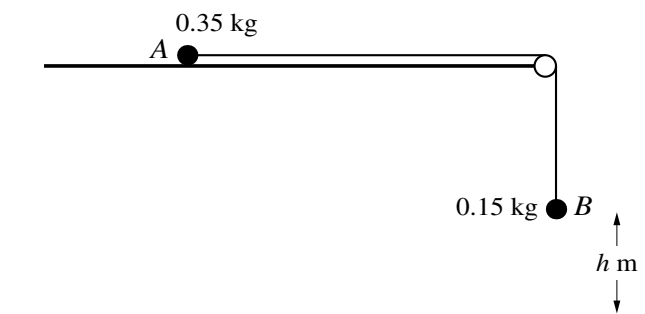

Fig. 2

Two particles P and Q have masses m kg and $(1 - m)$ kg respectively. The particles are attached to the ends of a light inextensible string which passes over a smooth fixed pulley. P is held at rest with the string taut and both straight parts of the string vertical. P and Q are each at a height of h m above horizontal ground (see Fig. 1). P is released and Q moves downwards. Subsequently Q hits the ground and comes to rest. Fig. 2 shows the velocity-time graph for P while Q is moving downwards or is at rest on the ground.

- (i) Find the value of h . [2]
- (ii) Find the value of m , and find also the tension in the string while Q is moving. [6]
- (iii) The string is slack while Q is at rest on the ground. Find the total time from the instant that P is released until the string becomes taut again. [3]

71. [9709/s15/43/q2]



Particles A and B , of masses 0.35 kg and 0.15 kg respectively, are attached to the ends of a light inextensible string. A is held at rest on a smooth horizontal surface with the string passing over a small smooth pulley fixed at the edge of the surface. B hangs vertically below the pulley at a distance $h\text{ m}$ above the floor (see diagram). A is released and the particles move. B reaches the floor and A subsequently reaches the pulley with a speed of 3 m s^{-1} .

- (i) Explain briefly why the speed with which B reaches the floor is 3 m s^{-1} . [1]
- (ii) Find the value of h . [4]

72. [9709/w15/41/q4]

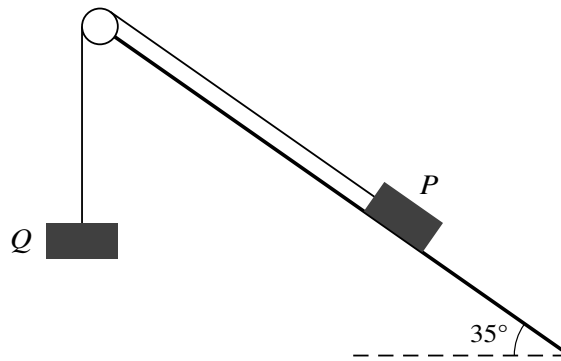

Blocks P and Q , of mass m kg and 5 kg respectively, are attached to the ends of a light inextensible string. The string passes over a small smooth pulley which is fixed at the top of a rough plane inclined at 35° to the horizontal. Block P is at rest on the plane and block Q hangs vertically below the pulley (see diagram). The coefficient of friction between block P and the plane is 0.2. Find the set of values of m for which the two blocks remain at rest. [6]

73. [9709/w15/42/q5]

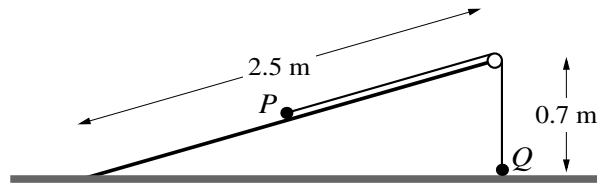

A smooth inclined plane of length 2.5 m is fixed with one end on the horizontal floor and the other end at a height of 0.7 m above the floor. Particles P and Q , of masses 0.5 kg and 0.1 kg respectively, are attached to the ends of a light inextensible string which passes over a small smooth pulley fixed at the top of the plane. Particle Q is held at rest on the floor vertically below the pulley. The string is taut and P is at rest on the plane (see diagram). Q is released and starts to move vertically upwards towards the pulley and P moves down the plane.

- (i) Find the tension in the string and the magnitude of the acceleration of the particles before Q reaches the pulley. [5]

At the instant just before Q reaches the pulley the string breaks; P continues to move down the plane and reaches the floor with a speed of 2 m s^{-1} .

- (ii) Find the length of the string. [3]

74. [9709/w15/43/q1]

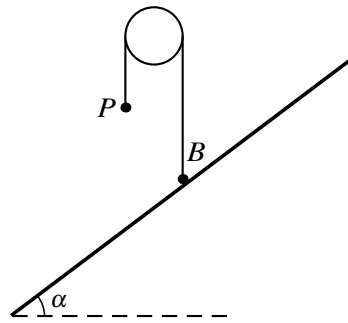

A small ball B of mass 4 kg is attached to one end of a light inextensible string. A particle P of mass 3 kg is attached to the other end of the string. The string passes over a fixed smooth pulley. The system is in equilibrium with the string taut and its straight parts vertical. B is at rest on a rough plane inclined to the horizontal at an angle of α , where $\cos \alpha = 0.8$ (see diagram). State the tension in the string and find the normal component of the contact force exerted on B by the plane. [3]

75. [9709/w15/43/q4]

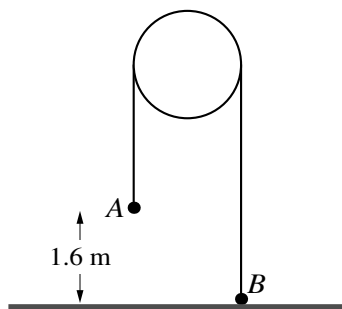

Particles A and B , of masses 0.35 kg and 0.15 kg respectively, are attached to the ends of a light inextensible string which passes over a fixed smooth pulley. The system is at rest with B held on the horizontal floor, the string taut and its straight parts vertical. A is at a height of 1.6 m above the floor (see diagram). B is released and the system begins to move; B does not reach the pulley. Find

- (i) the acceleration of the particles and the tension in the string before A reaches the floor, [4]
- (ii) the greatest height above the floor reached by B . [3]

Chapter 7

Energy, work and power

1. [9709/m25/42/q3]

An aeroplane is flying at a constant speed.

- (a)** The aeroplane is flying horizontally. The aeroplane's engines are producing a constant power of 5500 kW, and the aeroplane experiences a constant horizontal resistance force of 25 kN.

Find the speed of the aeroplane. [2]

- (b)** The aeroplane then ascends 300 m in 50 s, while maintaining the same speed. The resistance force is no longer constant, and the work done against the resistance force in ascending the 300 m is 270 000 kJ. The mass of the aeroplane is 60 000 kg.

Find the average power of the aeroplane's engines. [4]

2. [9709/s25/41/q4]

A lorry of mass 18 000 kg is travelling along a straight road.

(a) On a horizontal section of the road, the power of the lorry's engine is constant. There is a constant resistance to motion of 1600 N.

(i) The steady speed which the lorry can maintain with the engine working at power P W is 30 m s^{-1} .

Find the value of P . [1]

(ii) At an instant when the speed of the lorry is 16 m s^{-1} , its engine is working at a power of 40 kW.

Find the acceleration of the lorry at this instant. [2]

3. [9709/s25/42/q1]

A crate is being pushed in a straight line along a horizontal surface by a force of magnitude 25 N inclined at 20° above the horizontal. The crate moves a distance of 12 m in 8 seconds with constant speed.

- (a) Find the constant speed of the crate. [1]
- (b) Find the work done by the 25 N force. [2]
- (c) Find the power at which the 25 N force is working. [1]

4. [9709/s25/42/q7]

A particle P of mass 3 kg is projected with a speed of 8 m s^{-1} up a line of greatest slope of a rough plane inclined at 30° to the horizontal. P is projected from a point A on the plane and comes to instantaneous rest at a point B on the plane. P then slides back down the plane. The coefficient of friction between P and the plane is $\frac{1}{12}\sqrt{3}$.

Using an energy method throughout, find the speed of P at the instant it returns to A . [6]

5. [9709/s25/43/q5]

A van of mass 2500 kg travelling at speed $v \text{ m s}^{-1}$ experiences a resistance force of $kv^2 \text{ N}$. The constant power of the van's engine is 62.5 kW.

- (a) The steady speed that the van could maintain when moving along a straight horizontal road is 50 m s^{-1} .

Show that $k = 0.5$, and find the acceleration of the van when its speed is 25 m s^{-1} on this straight horizontal road. [4]

The van begins to ascend a hill inclined at an angle θ° to the horizontal. The van travels along a line of greatest slope of the hill. The speed of the van at the start of the hill is 20 m s^{-1} , and its acceleration is $5a \text{ m s}^{-2}$. Later, on the same hill, the speed of the van is 30 m s^{-1} , and its acceleration is $a \text{ m s}^{-2}$. The power of the van's engine remains at 62.5 kW, and the resistance force remains at $0.5v^2 \text{ N}$.

- (b) Find the value of a and the value of θ . [5]

6. [9709/s25/43/q6]

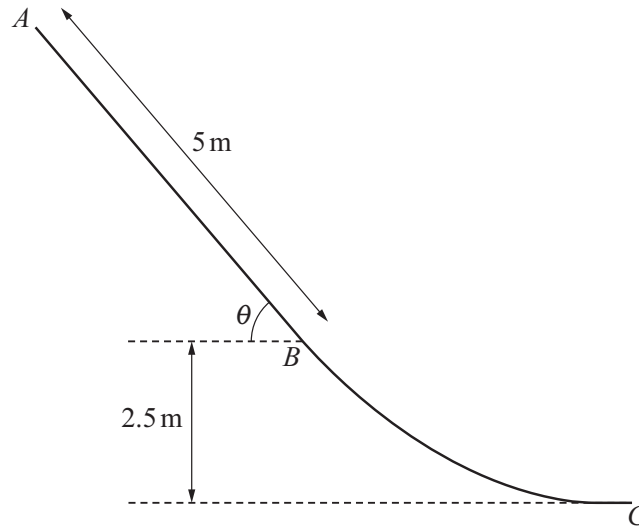

The diagram shows the vertical cross-section ABC of a rough waterslide. The section AB is a straight line of length 5 m inclined at an angle of θ to the horizontal, where $\sin \theta = 0.8$. The point B is 2.5 m above the level of C . A man of mass 80 kg, modelled as a particle, slides down the waterslide, starting from rest at A . The coefficient of friction between the man and the straight section of the waterslide is 0.1.

(a) Find the speed of the man at B . [5]

It is given that there is no change in the speed of the man when passing through B and that his speed at C is 11 m s^{-1} .

(b) Find the work done against the resistance force as the man moves from B to C . [4]

7. [9709/s25/45/q1]

A box of mass 25 kg is pulled 12 m up a rough plane inclined at an angle of 8° to the horizontal. The box moves up a line of greatest slope against a frictional force of 50 N. The force pulling the box is parallel to the line of greatest slope. The box starts from rest and has speed 2.4 m s^{-1} at the end of the 12 m.

Find the work done by the pulling force.

[4]

8. [9709/s25/45/q5]

A car of mass 1500 kg is travelling along a straight horizontal road.

- (a) It is given that there is a constant resistance to motion. The engine of the car is working at 24 kW while the car is travelling at a constant speed of 32 m s^{-1} . The power is now increased to 28 kW.

Find the acceleration of the car at the instant it is travelling at a speed of 36 m s^{-1} . [4]

- (b) It is given instead that the resistance to the motion of the car is $(340 + 4v) \text{ N}$ when the speed of the car is $v \text{ m s}^{-1}$.

When the engine is working at 20 kW, the car is travelling at constant speed.

Find this constant speed. [3]

9. [9709/w25/41/q1]

A car of mass 900 kg is moving along a straight horizontal road against a constant resistance to motion of 350 N. At an instant when the car is moving at 15 m s^{-1} its acceleration is 0.25 m s^{-2} .

- (a) Find the driving force of the car's engine at this instant. [2]
- (b) Find the power of the car's engine at this instant. [2]

10. [9709/w25/42/q3]

A car of mass 1400 kg travelling on a straight horizontal road accelerates uniformly from a speed of 15 m s^{-1} to 20 m s^{-1} over a distance of 175 m.

- (a)** Find the time taken to travel the 175 m. [2]

There is a constant resistance force of 800 N to the motion of the car.

- (b) (i)** Use an energy method throughout to find the average power of the car's engine as the speed increases from 15 m s^{-1} to 20 m s^{-1} . [4]
- (ii)** Find the steady speed that the car could maintain on the horizontal road if the engine is working at the power found in **(b)(i)**. [2]

11. [9709/w25/43/q2]

The engine of a motorcycle can generate a maximum power of 105 kW. The mass of the motorcycle and its rider is 400 kg. The total resistance to the motion of the motorcycle and its rider is $c\nu$ N, where ν m s⁻¹ is the motorcyclist's speed and c is a constant.

The motorcyclist travels along a straight horizontal road under maximum engine power. When the motorcyclist's speed is 35 m s⁻¹, his acceleration is 0.5 m s⁻².

(a) Show that $c = 80$. [3]

The motorcyclist now travels up a straight hill under maximum engine power. The hill makes an angle of $\sin^{-1}\left(\frac{3}{20}\right)$ with the horizontal.

(b) Find the steady speed at which the motorcyclist travels up the hill. [3]

12. [9709/w25/43/q3]

A block of mass 4 kg is pulled along a rough horizontal road by a constant force of magnitude 25 N acting at an angle of 36° above the horizontal. The block moves in a straight line passing through two points A and B on the road, where $AB = 120$ m. The coefficient of friction between the block and the road is 0.4.

(a) Find the work done against friction in moving the block from A to B . [3]

The speed of the block at A is 7 m s^{-1} .

(b) Use an energy method to find the speed of the block at B . [4]

13. [9709/w25/45/q3]

A car of mass 800 kg is moving on a straight road.

When the car is moving at a constant speed of 20 m s^{-1} on a horizontal section of the road, the engine of the car is working at $P \text{ W}$.

When the car is moving at a constant speed of 12 m s^{-1} up a section of the road inclined at $\sin^{-1} 0.15$ to the horizontal, the engine of the car is also working at $P \text{ W}$.

On both sections of the road there is a constant force of magnitude $R \text{ N}$ resisting the motion of the car.

(a) Find the value of R and the value of P . [5]

(b) Find the acceleration of the car when it is moving at 10 m s^{-1} up the inclined section of the road with the engine working at 32 kW . [3]

14. [9709/m24/42/q6]

A car of mass 1800 kg is towing a trailer of mass 300 kg up a straight road inclined at an angle α to the horizontal, where $\sin \alpha = 0.05$. The car and trailer are connected by a tow-bar which is light and rigid and is parallel to the road. There is a resistance force of 800 N acting on the car and a resistance force of F N acting on the trailer. The driving force of the car's engine is 3000 N.

- (a) It is given that $F = 100$.

Find the acceleration of the car and the tension in the tow-bar. [5]

- (b) It is given instead that the total work done against F in moving a distance of 50 m up the road is 6000 J. The speed of the car at the start of the 50 m is 20 m s^{-1} .

Use an energy method to find the speed of the car at the end of the 50 m. [5]

15. [9709/s24/41/q3]

A train of mass 180 000 kg ascends a straight hill of length 1.5 km, inclined at an angle of 1.5° to the horizontal. As it ascends the hill, the total work done to overcome the resistance to motion is 12 000 kJ and the speed of the train decreases from 45 m s^{-1} to 40 m s^{-1} .

Find the work done by the engine of the train as it ascends the hill, giving your answer in kJ. [4]

16. [9709/s24/41/q4]

A car of mass 1700 kg is pulling a trailer of mass 300 kg along a straight horizontal road. The car and trailer are connected by a light inextensible cable which is parallel to the road. There are constant resistances to motion of 400 N on the car and 150 N on the trailer. The power of the car's engine is 14 000 W.

Find the acceleration of the car and the tension in the cable when the speed is 20 ms^{-1} . [6]

17. [9709/s24/42/q1]

A cyclist and bicycle have a total mass of 72 kg. The cyclist rides along a horizontal road against a total resistance force of 28 N.

Find the total work done by the cyclist to increase his speed from 8 ms^{-1} to 16 ms^{-1} while travelling a distance of 100 metres. [3]

18. [9709/s24/42/q4]

A car has mass 1400 kg. When the speed of the car is $v \text{ m s}^{-1}$ the magnitude of the resistance to motion is $kv^2 \text{ N}$ where k is a constant.

(a) The car moves at a constant speed of 24 m s^{-1} up a hill inclined at an angle of α to the horizontal where $\sin \alpha = 0.12$. At this speed the magnitude of the resistance to motion is 480 N.

(i) Find the value of k . [1]

(ii) Find the power of the car's engine. [3]

(b) The car now moves at a constant speed on a straight level road.

Given that its engine is working at 54 kW, find this speed. [3]

19. [9709/s24/43/q6]

A cyclist is travelling along a straight horizontal road. The total mass of the cyclist and her bicycle is 80 kg. There is a constant resistance force of magnitude 32 N to the cyclist's motion. At an instant when she is travelling at 7 m s^{-1} , her acceleration is 0.1 m s^{-2} .

(a) Find the power output of the cyclist. [3]

(b) Find the steady speed that the cyclist can maintain if her power output and the resistance force are both unchanged. [2]

The cyclist later descends a straight hill of length 32.2 m, inclined at an angle of $\sin^{-1}\left(\frac{1}{20}\right)$ to the horizontal. Her power output is now 120 W, and the resistance force now has variable magnitude such that the work done against this force in descending the hill is 1128 J. The time taken to descend the hill is 4 s.

(c) Given that the speed of the cyclist at the top of the hill is 7.5 m s^{-1} , find her speed at the bottom of the hill. [6]

20. [9709/w24/41/q7]

A car has mass 1200 kg. When the car is travelling at a speed of $v \text{ m s}^{-1}$, there is a resistive force of magnitude $k v \text{ N}$. The maximum power of the car's engine is 92.16 kW.

(a) The car travels along a straight level road.

(i) The car has a greatest possible constant speed of 48 m s^{-1} .

Show that $k = 40$. [1]

(ii) At an instant when its speed is 45 m s^{-1} , find the greatest possible acceleration of the car. [3]

(b) The car now travels at a constant speed up a hill inclined at an angle of $\sin^{-1}0.15$ to the horizontal.

Find the greatest possible speed of the car going up the hill. [4]

21. [9709/w24/42/q2]

A block of mass 20 kg is held at rest at the top of a plane inclined at 30° to the horizontal. The block is projected with speed 5 m s^{-1} down a line of greatest slope of the plane. There is a resistance force acting on the block. As the block moves 2 m down the plane from its point of projection, the work done against this resistance force is 50 J.

Find the speed of the block when it has moved 2 m down the plane.

[4]

22. [9709/w24/42/q3]

A cyclist is riding along a straight horizontal road. The total mass of the cyclist and his bicycle is 90 kg. The power exerted by the cyclist is 250 W. At an instant when the cyclist's speed is 5 m s^{-1} , his acceleration is 0.1 m s^{-2} .

- (a) Find the value of the constant resistance to motion acting on the cyclist. [3]

The cyclist comes to the bottom of a hill inclined at 2° to the horizontal.

- (b) Given that the power and resistance to motion are unchanged, find the steady speed which the cyclist could maintain when riding up the hill. [2]

23. [9709/w24/43/q1]

An athlete has mass m kg. The athlete runs along a horizontal road against a constant resistance force of magnitude 24 N. The total work done by the athlete in increasing his speed from 5 m s^{-1} to 6 m s^{-1} while running a distance of 50 metres is 1541 J.

Find the value of m .

[4]

24. [9709/w24/43/q3]

A car of mass 1600 kg travels up a slope inclined at an angle of $\sin^{-1} 0.08$ to the horizontal. There is a constant resistance of magnitude 240 N acting on the car.

- (a) It is given that the car travels at a constant speed of 32 m s^{-1} .

Find the power of the engine of the car. [3]

- (b) Find the acceleration of the car when its speed is 24 m s^{-1} and the engine is working at 95% of the power found in (a). [3]

25. [9709/m23/42/q1]

A crate of mass 200 kg is being pulled at constant speed along horizontal ground by a horizontal rope attached to a winch. The winch is working at a constant rate of 4.5 kW and there is a constant resistance to the motion of the crate of magnitude 600 N.

(a) Find the time that it takes for the crate to move a distance of 15 m. [2]

The rope breaks after the crate has moved 15 m.

(b) Find the time taken, after the rope breaks, for the crate to come to rest. [3]

26. [9709/m23/42/q7]

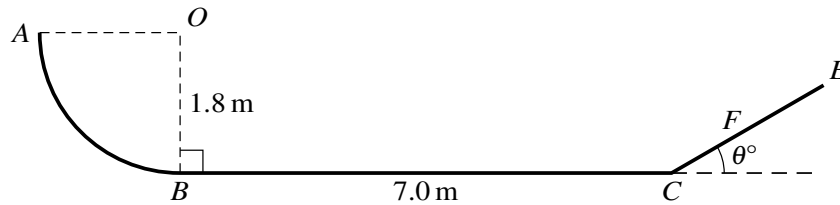

The diagram shows a smooth track which lies in a vertical plane. The section AB is a quarter circle of radius 1.8 m with centre O . The section BC is a horizontal straight line of length 7.0 m and OB is perpendicular to BC . The section CFE is a straight line inclined at an angle of θ° above the horizontal.

A particle P of mass 0.5 kg is released from rest at A . Particle P collides with a particle Q of mass 0.1 kg which is at rest at B . Immediately after the collision, the speed of P is 4 m s^{-1} in the direction BC . You should assume that P is moving horizontally when it collides with Q .

(a) Show that the speed of Q immediately after the collision is 10 m s^{-1} . [4]

When Q reaches C , it collides with a particle R of mass 0.4 kg which is at rest at C . The two particles coalesce. The combined particle comes instantaneously to rest at F . You should assume that there is no instantaneous change in speed as the combined particle leaves C , nor when it passes through C again as it returns down the slope.

(b) Given that the distance CF is 0.4 m , find the value of θ . [4]

(c) Find the distance from B at which P collides with the combined particle. [5]

27. [9709/s23/41/q2]

A particle P of mass 0.4 kg is projected vertically upwards from horizontal ground with speed 10 m s^{-1} .

(a) Find the greatest height above the ground reached by P . [2]

When P reaches the ground again, it bounces vertically upwards. At the first instant that it hits the ground, P loses 7.2 J of energy.

(b) Find the time between the first and second instants at which P hits the ground. [4]

28. [9709/s23/41/q7]

A car of mass 1200 kg is travelling along a straight horizontal road. The power of the car's engine is constant and is equal to 16 kW. There is a constant resistance to motion of magnitude 500 N.

(a) Find the acceleration of the car at an instant when its speed is 20 m s^{-1} . [3]

(b) Assuming that the power and the resistance forces remain unchanged, find the steady speed at which the car can travel. [2]

The car comes to the bottom of a straight hill of length 316 m, inclined at an angle to the horizontal of $\sin^{-1}\left(\frac{1}{60}\right)$. The power remains constant at 16 kW, but the magnitude of the resistance force is no longer constant and changes such that the work done against the resistance force in ascending the hill is 128 400 J. The time taken to ascend the hill is 15 s.

(c) Given that the car is travelling at a speed of 20 m s^{-1} at the bottom of the hill, find its speed at the top of the hill. [6]

29. [9709/s23/42/q1]

A particle of mass 1.6 kg is dropped from a height of 9 m above horizontal ground. The speed of the particle at the instant before hitting the ground is 12 m s^{-1} .

Find the work done against air resistance.

[3]

30. [9709/s23/42/q4]

An athlete of mass 84 kg is running along a straight road.

- (a) Initially the road is horizontal and he runs at a constant speed of 3 m s^{-1} . The athlete produces a constant power of 60 W.

Find the resistive force which acts on the athlete. [1]

- (b) The athlete then runs up a 150 m section of the road which is inclined at 0.8° to the horizontal. The speed of the athlete at the start of this section of road is 3 m s^{-1} and he now produces a constant driving force of 24 N. The total resistive force which acts on the athlete along this section of road has constant magnitude 13 N.

Use an energy method to find the speed of the athlete at the end of the 150 m section of road. [6]

31. [9709/s23/43/q4]

A lorry of mass 15 000 kg moves on a straight horizontal road in the direction from A to B . It passes A and B with speeds 20 m s^{-1} and 25 m s^{-1} respectively. The power of the lorry's engine is constant and there is a constant resistance to motion of magnitude 6000 N. The acceleration of the lorry at B is 0.5 times the acceleration of the lorry at A .

- (a) Show that the power of the lorry's engine is 200 kW, and hence find the acceleration of the lorry when it is travelling at 20 m s^{-1} . [5]

The lorry begins to ascend a straight hill inclined at 1° to the horizontal. It is given that the power of the lorry's engine and the resistance force do not change.

- (b) Find the steady speed up the hill that the lorry could maintain. [2]

32. [9709/s23/43/q7]

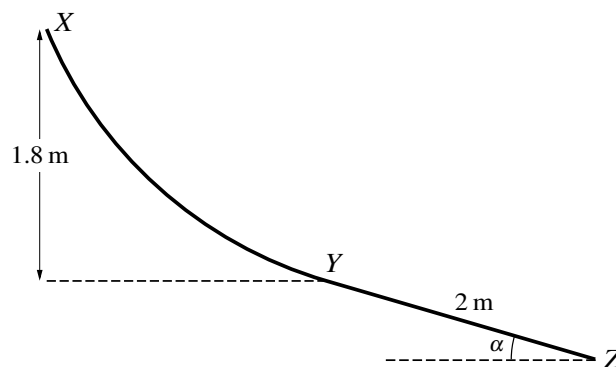

The diagram shows the vertical cross-section XYZ of a rough slide. The section YZ is a straight line of length 2 m inclined at an angle of α to the horizontal, where $\sin \alpha = 0.28$. The section YZ is tangential to the curved section XY at Y , and X is 1.8 m above the level of Y . A child of mass 25 kg slides down the slide, starting from rest at X . The work done by the child against the resistance force in moving from X to Y is 50 J.

(a) Find the speed of the child at Y . [4]

It is given that the child comes to rest at Z .

(b) Use an energy method to find the coefficient of friction between the child and YZ , giving your answer as a fraction in its simplest form. [6]

33. [9709/w23/41/q1]

A particle of mass 1.6 kg is projected with a speed of 20 m s^{-1} up a line of greatest slope of a smooth plane inclined at α to the horizontal, where $\tan \alpha = \frac{3}{4}$.

Use an energy method to find the distance the particle moves up the plane before coming to instantaneous rest. [3]

34. [9709/w23/41/q6]

A car of mass 1300 kg is moving on a straight road.

- (a) On a horizontal section of the road, the car has a constant speed of 30 m s^{-1} and there is a constant force of 650 N resisting the motion.
- (i) Calculate, in kW, the power developed by the engine of the car. [2]
- (ii) Given that this power is suddenly increased by 9 kW, find the instantaneous acceleration of the car. [3]
- (b) On a section of the road inclined at $\sin^{-1} 0.08$ to the horizontal, the resistance to the motion of the car is $(1000 + 20v) \text{ N}$ when the speed of the car is $v \text{ m s}^{-1}$. The car travels downwards along this section of the road at constant speed with the engine working at 11.5 kW.

Find this constant speed. [4]

35. [9709/w23/42/q1]

A block of mass 15 kg slides down a line of greatest slope of an inclined plane. The top of the plane is at a vertical height of 1.6 m above the level of the bottom of the plane. The speed of the block at the top of the plane is 2 m s^{-1} and the speed of the block at the bottom of the plane is 4 m s^{-1} .

Find the work done against the resistance to motion of the block.

[4]

36. [9709/w23/42/q3]

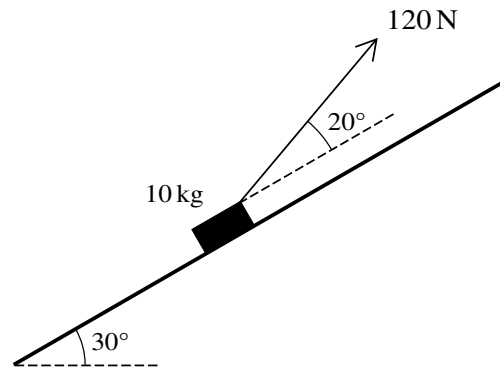

A block of mass 10 kg is at rest on a rough plane inclined at an angle of 30° to the horizontal. A force of 120 N is applied to the block at an angle of 20° above a line of greatest slope (see diagram). There is a force resisting the motion of the block and 200 J of work is done against this force when the block has moved a distance of 5 m up the plane from rest.

Find the speed of the block when it has moved a distance of 5 m up the plane from rest. [5]

37. [9709/w23/43/q4]

A car has mass 1600 kg.

- (a) The car is moving along a straight horizontal road at a constant speed of 24 m s^{-1} and is subject to a constant resistance of magnitude 480 N.

Find, in kW, the rate at which the engine of the car is working. [2]

The car now moves down a hill inclined at an angle of θ to the horizontal, where $\sin \theta = 0.09$. The engine of the car is working at a constant rate of 12 kW. The speed of the car is 24 m s^{-1} at the top of the hill. Ten seconds later the car has travelled 280 m down the hill and has speed 32 m s^{-1} .

- (b) Given that the resistance is not constant, use an energy method to find the total work done against the resistance during the ten seconds. [5]

38. [9709/m22/42/q1]

A crane is used to raise a block of mass 600 kg vertically upwards at a constant speed through a height of 15 m. There is a resistance to the motion of the block, which the crane does 10 000 J of work to overcome.

- (a) Find the total work done by the crane. [2]
- (b) Given that the average power exerted by the crane is 12.5 kW, find the total time for which the block is in motion. [2]

39. [9709/m22/42/q4]

The total mass of a cyclist and her bicycle is 70 kg. The cyclist is riding with constant power of 180 W up a straight hill inclined at an angle α to the horizontal, where $\sin \alpha = 0.05$. At an instant when the cyclist's speed is 6 m s^{-1} , her acceleration is -0.2 m s^{-2} . There is a constant resistance to motion of magnitude $F \text{ N}$.

(a) Find the value of F . [4]

(b) Find the steady speed that the cyclist could maintain up the hill when working at this power. [2]

40. [9709/s22/41/q5]

Two racing cars A and B are at rest alongside each other at a point O on a straight horizontal test track. The mass of A is 1200 kg . The engine of A produces a constant driving force of 4500 N . When A arrives at a point P its speed is 25 m s^{-1} . The distance OP is $d\text{ m}$. The work done against the resistance force experienced by A between O and P is $75\,000\text{ J}$.

(a) Show that $d = 100$. [3]

Car B starts off at the same instant as car A . The two cars arrive at P simultaneously and with the same speed. The engine of B produces a driving force of 3200 N and the car experiences a constant resistance to motion of 1200 N .

(b) Find the mass of B . [3]

(c) Find the steady speed which B can maintain when its engine is working at the same rate as it is at P . [3]

41. [9709/s22/42/q6]

A car of mass 900 kg is moving up a hill inclined at $\sin^{-1} 0.12$ to the horizontal. The initial speed of the car is 11 m s^{-1} . After 12 s , the car has travelled 150 m up the hill and has speed 16 m s^{-1} . The engine of the car is working at a constant rate of 24 kW .

(a) Find the work done against the resistive forces during the 12 s . [5]

The car then travels along a straight horizontal road. There is a resistance to the motion of the car of $(1520 + 4v)\text{ N}$ when the speed of the car is $v\text{ m s}^{-1}$. The car travels at a constant speed with the engine working at a constant rate of 32 kW .

(b) Find this speed. [3]

42. [9709/s22/43/q5]

A cyclist is riding along a straight horizontal road. The total mass of the cyclist and her bicycle is 70 kg. At an instant when the cyclist's speed is 4 m s^{-1} , her acceleration is 0.3 m s^{-2} . There is a constant resistance to motion of magnitude 30 N.

(a) Find the power developed by the cyclist. [3]

The cyclist comes to the top of a hill inclined at 5° to the horizontal. The cyclist stops pedalling and freewheels down the hill (so that the cyclist is no longer supplying any power). The magnitude of the resistance force remains at 30 N. Over a distance of d m, the speed of the cyclist increases from 6 m s^{-1} to 12 m s^{-1} .

(b) Find the change in kinetic energy. [2]

(c) Use an energy method to find d . [3]

43. [9709/w22/41/q3]

A constant resistance of magnitude 1400 N acts on a car of mass 1250 kg.

- (a) The car is moving along a straight level road at a constant speed of 28 m s^{-1} .

Find, in kW, the rate at which the engine of the car is working. [2]

- (b) The car now travels at a constant speed up a hill inclined at an angle of θ to the horizontal, where $\sin \theta = 0.12$, with the engine working at 43.5 kW.

Find this speed. [3]

- (c) On another occasion, the car pulls a trailer of mass 600 kg up the same hill. The system of the car and the trailer is modelled as particles connected by a light inextensible cable. The car's engine produces a driving force of 5000 N and the resistance to the motion of the trailer is 300 N. The resistance to the motion of the car remains 1400 N.

Find the acceleration of the system and the tension in the cable. [4]

44. [9709/w22/41/q6]

**Fig. 6.1**

Fig. 6.1 shows particles A and B , of masses 4 kg and 3 kg respectively, attached to the ends of a light inextensible string that passes over a small smooth pulley. The pulley is fixed at the top of a plane which is inclined at an angle of 30° to the horizontal. A hangs freely below the pulley and B is on the inclined plane. The string is taut and the section of the string between B and the pulley is parallel to a line of greatest slope of the plane.

(a) It is given that the plane is rough and the particles are in limiting equilibrium.

Find the coefficient of friction between B and the plane.

[6]

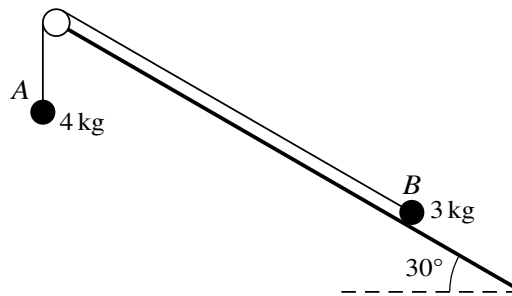
(b)

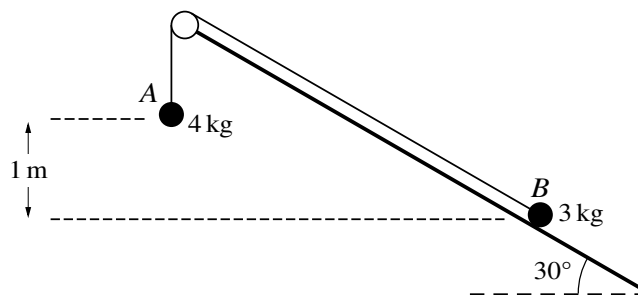
**Fig. 6.2**

It is given instead that the plane is smooth and the particles are released from rest when the difference in the vertical heights of the particles is 1 m (see Fig. 6.2).

Use an energy method to find the speed of the particles at the instant when the particles are at the same horizontal level.

[6]

45. [9709/w22/42/q1]

A cyclist is riding a bicycle along a straight horizontal road AB of length 50 m. The cyclist starts from rest at A and reaches a speed of 6 m s^{-1} at B . The cyclist produces a constant driving force of magnitude 100 N. There is a resistance force, and the work done against the resistance force from A to B is 3560 J.

Find the total mass of the cyclist and bicycle.

[3]

46. [9709/w22/42/q4]

A car of mass 1200 kg is travelling along a straight horizontal road AB . There is a constant resistance force of magnitude 500 N. When the car passes point A , it has a speed of 15 m s^{-1} and an acceleration of 0.8 m s^{-2} .

(a) Find the power of the car's engine at the point A . [3]

The car continues to work with this power as it travels from A to B . The car takes 53 seconds to travel from A to B and the speed of the car at B is 32 m s^{-1} .

(b) Show that the distance AB is 1362.6 m. [3]

47. [9709/w22/43/q2]

A box of mass 5 kg is pulled at a constant speed of 1.8 m s^{-1} for 15 s up a rough plane inclined at an angle of 20° to the horizontal. The box moves along a line of greatest slope against a frictional force of 40 N. The force pulling the box is parallel to the line of greatest slope.

(a) Find the change in gravitational potential energy of the box. [2]

(b) Find the work done by the pulling force. [2]

48. [9709/w22/43/q6]

A car of mass 1750 kg is pulling a caravan of mass 500 kg. The car and the caravan are connected by a light rigid tow-bar. The resistances to the motion of the car and caravan are 650 N and 150 N respectively.

(a) The car and caravan are moving along a straight horizontal road at a constant speed of 24 m s^{-1} .

(i) Find the power of the car's engine. [2]

(ii) The engine's power is now suddenly increased to 40 kW.

Find the instantaneous acceleration of the car and caravan and find the tension in the tow-bar. [5]

(b) The car and caravan now travel up a straight hill, inclined at an angle $\sin^{-1} 0.14$ to the horizontal, at a constant speed of $v \text{ m s}^{-1}$. The car's engine is working at 31 kW. The resistances to the motion of the car and caravan are unchanged.

Find v . [3]

49. [9709/w22/43/q7]

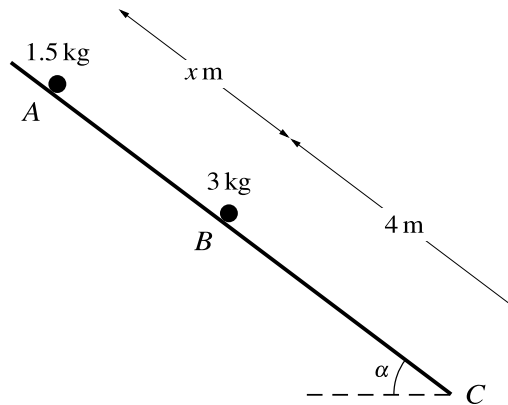

Particles of masses 1.5 kg and 3 kg lie on a plane which is inclined at an angle of α to the horizontal, where $\tan \alpha = \frac{3}{4}$. The section of the plane from A to B is smooth and the section of the plane from B to C is rough. The 1.5 kg particle is held at rest at A and the 3 kg particle is in limiting equilibrium at B . The distance AB is x m and the distance BC is 4 m (see diagram).

(a) Show that the coefficient of friction between the particle at B and the plane is 0.75. [3]

The 1.5 kg particle is released from rest. In the subsequent motion the two particles collide and coalesce. The time taken for the combined particle to travel from B to C is 2 s. The coefficient of friction between the combined particle and the plane is still 0.75.

(b) Find x . [6]

(c) Find the total loss of energy of the particles from the time the 1.5 kg particle is released until the combined particle reaches C . [3]

50. [9709/m21/42/q2]

A car of mass 1400 kg is travelling at constant speed up a straight hill inclined at α to the horizontal, where $\sin \alpha = 0.1$. There is a constant resistance force of magnitude 600 N. The power of the car's engine is 22 500 W.

- (a) Show that the speed of the car is 11.25 m s^{-1} . [3]

The car, moving with speed 11.25 m s^{-1} , comes to a section of the hill which is inclined at 2° to the horizontal.

- (b) Given that the power and resistance force do not change, find the initial acceleration of the car up this section of the hill. [3]

51. [9709/m21/42/q7]

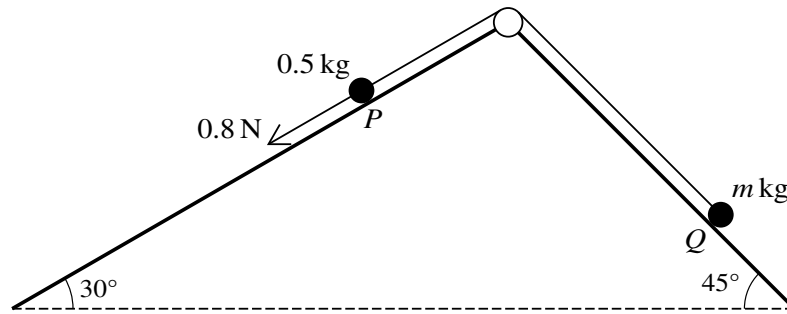

Two particles P and Q of masses 0.5 kg and $m \text{ kg}$ respectively are attached to the ends of a light inextensible string. The string passes over a fixed smooth pulley which is attached to the top of two inclined planes. The particles are initially at rest with P on a smooth plane inclined at 30° to the horizontal and Q on a plane inclined at 45° to the horizontal. The string is taut and the particles can move on lines of greatest slope of the two planes. A force of magnitude 0.8 N is applied to P acting down the plane, causing P to move down the plane (see diagram).

- (a) It is given that $m = 0.3$, and that the plane on which Q rests is smooth.

Find the tension in the string. [5]

- (b) It is given instead that the plane on which Q rests is rough, and that after each particle has moved a distance of 1 m , their speed is 0.6 m s^{-1} . The work done against friction in this part of the motion is 0.5 J .

Use an energy method to find the value of m . [5]

52. [9709/s21/41/q1]

A winch operates by means of a force applied by a rope. The winch is used to pull a load of mass 50 kg up a line of greatest slope of a plane inclined at 60° to the horizontal. The winch pulls the load a distance of 5 m up the plane at constant speed. There is a constant resistance to motion of 100 N.

Find the work done by the winch.

[3]

53. [9709/s21/41/q7]

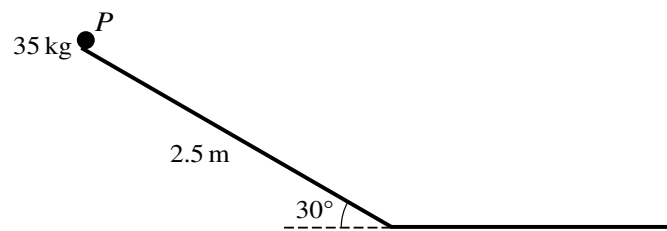

A slide in a playground descends at a constant angle of 30° for 2.5 m . It then has a horizontal section in the same vertical plane as the sloping section. A child of mass 35 kg , modelled as a particle P , starts from rest at the top of the slide and slides straight down the sloping section. She then continues along the horizontal section until she comes to rest (see diagram). There is no instantaneous change in speed when the child goes from the sloping section to the horizontal section.

The child experiences a resistance force on the horizontal section of the slide, and the work done against the resistance force on the horizontal section of the slide is 250 J per metre.

- (a) It is given that the sloping section of the slide is smooth.
- (i) Find the speed of the child when she reaches the bottom of the sloping section. [3]
 - (ii) Find the distance that the child travels along the horizontal section of the slide before she comes to rest. [2]
- (b) It is given instead that the sloping section of the slide is rough and that the child comes to rest on the slide 1.05 m after she reaches the horizontal section.

Find the coefficient of friction between the child and the sloping section of the slide. [6]

54. [9709/s21/42/q1]

A particle of mass 0.6 kg is projected with a speed of 4 m s^{-1} down a line of greatest slope of a smooth plane inclined at 10° to the horizontal.

Use an energy method to find the speed of the particle after it has moved 15 m down the plane. [3]

55. [9709/s21/43/q2]

A cyclist is travelling along a straight horizontal road. She is working at a constant rate of 150 W. At an instant when her speed is 4 m s^{-1} , her acceleration is 0.25 m s^{-2} . The resistance to motion is 20 N.

(a) Find the total mass of the cyclist and her bicycle. [3]

The cyclist comes to a straight hill inclined at an angle θ above the horizontal. She ascends the hill at constant speed 3 m s^{-1} . She continues to work at the same rate as before and the resistance force is unchanged.

(b) Find the value of θ . [2]

56. [9709/w21/41/q5]

A car of mass 1600 kg travels at constant speed 20 m s^{-1} up a straight road inclined at an angle of $\sin^{-1} 0.12$ to the horizontal.

- (a) Find the change in potential energy of the car in 30 s. [3]
- (b) Given that the total work done by the engine of the car in this time is 1960 kJ, find the constant force resisting the motion. [3]
- (c) Calculate, in kW, the power developed by the engine of the car. [2]
- (d) Given that this power is suddenly decreased by 15%, find the instantaneous deceleration of the car. [3]

57. [9709/w21/42/q3]

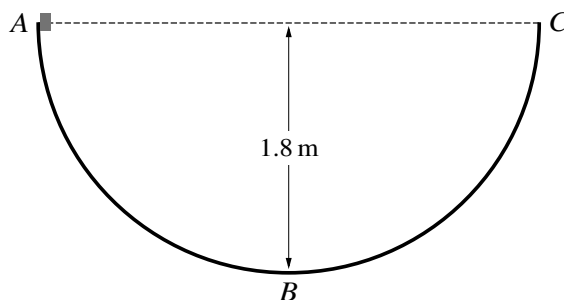

The diagram shows a semi-circular track ABC of radius 1.8 m which is fixed in a vertical plane. The points A and C are at the same horizontal level and the point B is at the bottom of the track. The section AB is smooth and the section BC is rough. A small block is released from rest at A .

(a) Show that the speed of the block at B is 6 m s^{-1} . [2]

The block comes to instantaneous rest for the first time at a height of 1.2 m above the level of B . The work done against the resistance force during the motion of the block from B to this point is 4.5 J .

(b) Find the mass of the block. [3]

58. [9709/w21/42/q5]

A railway engine of mass 75 000 kg is moving up a straight hill inclined at an angle α to the horizontal, where $\sin \alpha = 0.01$. The engine is travelling at a constant speed of 30 m s^{-1} . The engine is working at 960 kW. There is a constant force resisting the motion of the engine.

(a) Find the resistance force. [3]

The engine comes to a section of track which is horizontal. At the start of the section the engine is travelling at 30 m s^{-1} and the power of the engine is now reduced to 900 kW. The resistance to motion is no longer constant, but in the next 60 s the work done against the resistance force is 46 500 kJ.

(b) Find the speed of the engine at the end of the 60 s. [4]

59. [9709/w21/43/q3]

A ball of mass 1.6 kg is released from rest at a point 5 m above horizontal ground. When the ball hits the ground it instantaneously loses 8 J of kinetic energy and starts to move upwards.

(a) Use an energy method to find the greatest height that the ball reaches after hitting the ground.

[3]

(b) Find the total time taken, from the initial release of the ball until it reaches this greatest height.

[3]

60. [9709/w21/43/q4]

A car of mass 1400 kg is moving on a straight road against a constant force of 1250 N resisting the motion.

- (a) The car moves along a horizontal section of the road at a constant speed of 36 m s^{-1} .
- (i) Calculate the work done against the resisting force during the first 8 seconds. [2]
 - (ii) Calculate, in kW, the power developed by the engine of the car. [2]
 - (iii) Given that this power is suddenly increased by 12 kW, find the instantaneous acceleration of the car. [3]
- (b) The car now travels at a constant speed of 32 m s^{-1} up a section of the road inclined at θ° to the horizontal, with the engine working at 64 kW.

Find the value of θ . [2]

61. [9709/m20/42/q1]

A lorry of mass 16 000 kg is travelling along a straight horizontal road. The engine of the lorry is working at constant power. The work done by the driving force in 10 s is 750 000 J.

(a) Find the power of the lorry's engine. [1]

(b) There is a constant resistance force acting on the lorry of magnitude 2400 N.

Find the acceleration of the lorry at an instant when its speed is 25 m s^{-1} . [3]

62. [9709/m20/42/q3]

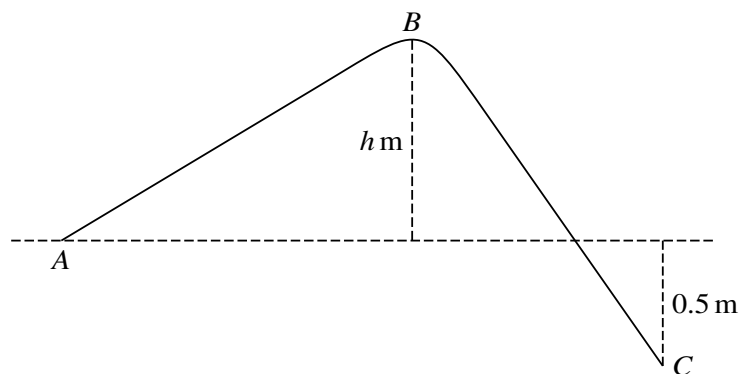

The diagram shows the vertical cross-section of a surface. A , B and C are three points on the cross-section. The level of B is $h\text{ m}$ above the level of A . The level of C is 0.5 m below the level of A . A particle of mass 0.2 kg is projected up the slope from A with initial speed 5 m s^{-1} . The particle remains in contact with the surface as it travels from A to C .

- (a) Given that the particle reaches B with a speed of 3 m s^{-1} and that there is no resistance force, find h . [3]
- (b) It is given instead that there is a resistance force and that the particle does 3.1 J of work against the resistance force as it travels from A to C .

Find the speed of the particle when it reaches C . [3]

63. [9709/s20/41/q5]

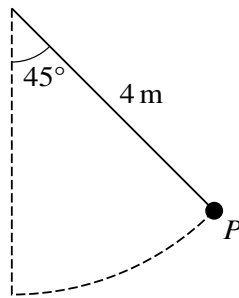

A child of mass 35 kg is swinging on a rope. The child is modelled as a particle P and the rope is modelled as a light inextensible string of length 4 m. Initially P is held at an angle of 45° to the vertical (see diagram).

- (a) Given that there is no resistance force, find the speed of P when it has travelled half way along the circular arc from its initial position to its lowest point. [4]
- (b) It is given instead that there is a resistance force. The work done against the resistance force as P travels from its initial position to its lowest point is X J. The speed of P at its lowest point is 4 m s^{-1} .

Find X .

[3]

64. [9709/s20/42/q5]

A car of mass 1250 kg is moving on a straight road.

(a) On a horizontal section of the road, the car has a constant speed of 32 m s^{-1} and there is a constant force of 750 N resisting the motion.

(i) Calculate, in kW, the power developed by the engine of the car. [2]

(ii) Given that this power is suddenly decreased by 8 kW, find the instantaneous deceleration of the car. [3]

(b) On a section of the road inclined at $\sin^{-1} 0.096$ to the horizontal, the resistance to the motion of the car is $(1000 + 8v) \text{ N}$ when the speed of the car is $v \text{ m s}^{-1}$. The car travels up this section of the road at constant speed with the engine working at 60 kW.

Find this constant speed. [5]

65. [9709/s20/43/q2]

A minibus of mass 4000 kg is travelling along a straight horizontal road. The resistance to motion is 900 N.

(a) Find the driving force when the acceleration of the minibus is 0.5 m s^{-2} . [2]

(b) Find the power required for the minibus to maintain a constant speed of 25 m s^{-1} . [2]

66. [9709/s20/43/q5]

A block B of mass 4 kg is pushed up a line of greatest slope of a smooth plane inclined at 30° to the horizontal by a force applied to B , acting in the direction of motion of B . The block passes through points P and Q with speeds 12 m s^{-1} and 8 m s^{-1} respectively. P and Q are 10 m apart with P below the level of Q .

(a) Find the decrease in kinetic energy of the block as it moves from P to Q . [2]

(b) Hence find the work done by the force pushing the block up the slope as the block moves from P to Q . [3]

(c) At the instant the block reaches Q , the force pushing the block up the slope is removed.

Find the time taken, after this instant, for the block to return to P . [4]

67. [9709/w20/41/q2]

A car of mass 1400 kg is moving along a straight horizontal road against a resistance of magnitude 350 N.

- (a) Find, in kW, the rate at which the engine of the car is working when it is travelling at a constant speed of 20 m s^{-1} . [2]
- (b) Find the acceleration of the car when its speed is 20 m s^{-1} and the engine is working at 15 kW. [3]

68. [9709/w20/41/q6]

A car of mass 1500 kg is pulling a trailer of mass 750 kg up a straight hill of length 800 m inclined at an angle of $\sin^{-1} 0.08$ to the horizontal. The resistances to the motion of the car and trailer are 400 N and 200 N respectively. The car and trailer are connected by a light rigid tow-bar. The car and trailer have speed 30 m s^{-1} at the bottom of the hill and 20 m s^{-1} at the top of the hill.

- (a) Use an energy method to find the constant driving force as the car and trailer travel up the hill.

[5]

After reaching the top of the hill the system consisting of the car and trailer travels along a straight level road. The driving force of the car's engine is 2400 N and the resistances to motion are unchanged.

- (b) Find the acceleration of the system and the tension in the tow-bar.

[4]

69. [9709/w20/42/q2]

A car of mass 1800 kg is travelling along a straight horizontal road. The power of the car's engine is constant. There is a constant resistance to motion of 650 N.

- (a) Find the power of the car's engine, given that the car's acceleration is 0.5 m s^{-2} when its speed is 20 m s^{-1} . [3]
- (b) Find the steady speed which the car can maintain with the engine working at this power. [2]

70. [9709/w20/43/q2]

A box of mass 5 kg is pulled at a constant speed a distance of 15 m up a rough plane inclined at an angle of 20° to the horizontal. The box moves along a line of greatest slope against a frictional force of 40 N. The force pulling the box is parallel to the line of greatest slope.

- (a) Find the work done against friction. [1]
- (b) Find the change in gravitational potential energy of the box. [2]
- (c) Find the work done by the pulling force. [1]

71. [9709/w20/43/q6]

A car of mass 1600 kg is pulling a caravan of mass 800 kg. The car and the caravan are connected by a light rigid tow-bar. The resistances to the motion of the car and caravan are 400 N and 250 N respectively.

(a) The car and caravan are travelling along a straight horizontal road.

(i) Given that the car and caravan have a constant speed of 25 m s^{-1} , find the power of the car's engine. [2]

(ii) The engine's power is now suddenly increased to 39 kW. Find the instantaneous acceleration of the car and caravan and find the tension in the tow-bar. [5]

(b) The car and caravan now travel up a straight hill, inclined at an angle of $\sin^{-1} 0.05$ to the horizontal, at a constant speed of $v \text{ m s}^{-1}$. The car's engine is working at 32.5 kW.

Find v . [3]

72. [9709/m19/42/q4]

A car of mass 1500 kg is pulling a trailer of mass 300 kg along a straight horizontal road at a constant speed of 20 m s^{-1} . The system of the car and trailer is modelled as two particles, connected by a light rigid horizontal rod. The power of the car's engine is 6000 W. There are constant resistances to motion of $R \text{ N}$ on the car and 80 N on the trailer.

- (i) Find the value of R . [2]

The power of the car's engine is increased to 12 500 W. The resistance forces do not change.

- (ii) Find the acceleration of the car and trailer and the tension in the rod at an instant when the speed of the car is 25 m s^{-1} . [5]

73. [9709/m19/42/q7]

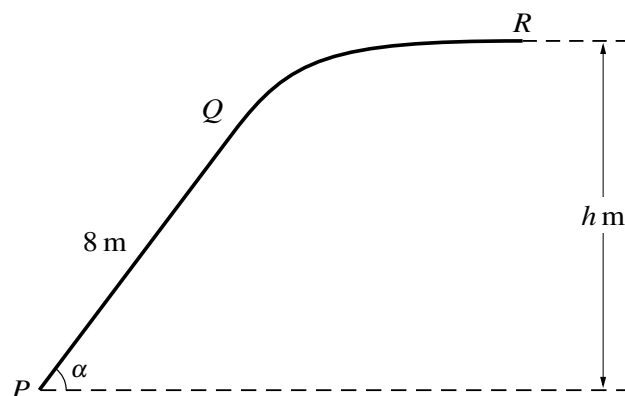

The diagram shows the vertical cross-section PQR of a slide. The part PQ is a straight line of length 8 m inclined at angle α to the horizontal, where $\sin \alpha = 0.8$. The straight part PQ is tangential to the curved part QR , and R is $h\text{ m}$ above the level of P . The straight part PQ of the slide is rough and the curved part QR is smooth. A particle of mass 0.25 kg is projected with speed 15 m s^{-1} from P towards Q and comes to rest at R . The coefficient of friction between the particle and PQ is 0.5 .

- (i) Find the work done by the friction force during the motion of the particle from P to Q . [4]
- (ii) Hence find the speed of the particle at Q . [4]
- (iii) Find the value of h . [3]

74. [9709/s19/41/q3]

A lorry has mass 12 000 kg.

- (i) The lorry moves at a constant speed of 5 m s^{-1} up a hill inclined at an angle of θ to the horizontal, where $\sin \theta = 0.08$. At this speed, the magnitude of the resistance to motion on the lorry is 1500 N. Show that the power of the lorry's engine is 55.5 kW. [3]

When the speed of the lorry is $v \text{ m s}^{-1}$ the magnitude of the resistance to motion is $kv^2 \text{ N}$, where k is a constant.

- (ii) Show that $k = 60$. [1]
- (iii) The lorry now moves at a constant speed on a straight level road. Given that its engine is still working at 55.5 kW, find the lorry's speed. [3]

75. [9709/s19/41/q4]

A particle of mass 1.3 kg rests on a rough plane inclined at an angle θ to the horizontal, where $\tan \theta = \frac{12}{5}$. The coefficient of friction between the particle and the plane is μ .

- (i) A force of magnitude 20 N parallel to a line of greatest slope of the plane is applied to the particle and the particle is on the point of moving up the plane. Show that $\mu = 1.6$. [4]

The force of magnitude 20 N is now removed.

- (ii) Find the acceleration of the particle. [2]
- (iii) Find the work done against friction during the first 2 s of motion. [3]

76. [9709/s19/42/q3]

A particle of mass 13 kg is on a rough plane inclined at an angle of θ to the horizontal, where $\tan \theta = \frac{5}{12}$. The coefficient of friction between the particle and the plane is 0.3. A force of magnitude T N, acting parallel to a line of greatest slope, moves the particle a distance of 2.5 m up the plane at a constant speed. Find the work done by this force. [5]

77. [9709/s19/42/q6]

A car has mass 1000 kg. When the car is travelling at a steady speed of $v \text{ m s}^{-1}$, where $v > 2$, the resistance to motion of the car is $(Av + B) \text{ N}$, where A and B are constants. The car can travel along a horizontal road at a steady speed of 18 m s^{-1} when its engine is working at 36 kW. The car can travel up a hill inclined at an angle of θ to the horizontal, where $\sin \theta = 0.05$, at a steady speed of 12 m s^{-1} when its engine is working at 21 kW. Find A and B . [7]

78. [9709/s19/43/q3]

A car of mass 1400 kg is travelling up a hill inclined at an angle of 4° to the horizontal. There is a constant resistance to motion of magnitude 1550 N acting on the car.

- (i) Given that the engine of the car is working at 30 kW, find the speed of the car at an instant when its acceleration is 0.4 m s^{-2} . [4]
- (ii) The greatest possible constant speed at which the car can travel up the hill is 40 m s^{-1} . Find the maximum possible power of the engine. [3]

79. [9709/s19/43/q5]

A particle of mass 18 kg is on a plane inclined at an angle of 30° to the horizontal. The particle is projected up a line of greatest slope of the plane with a speed of 20 m s^{-1} .

- (i) Given that the plane is smooth, use an energy method to find the distance the particle moves up the plane before coming to instantaneous rest. [4]
- (ii) Given instead that the plane is rough and the coefficient of friction between the particle and the plane is 0.25, find the speed of the particle as it returns to its starting point. [8]

80. [9709/w19/41/q1]

A crane is lifting a load of 1250 kg vertically at a constant speed $V \text{ m s}^{-1}$. Given that the power of the crane is a constant 20 kW, find the value of V . [2]

81. [9709/w19/41/q2]

The total mass of a cyclist and her bicycle is 75 kg. The cyclist ascends a straight hill of length 0.7 km inclined at 1.5° to the horizontal. Her speed at the bottom of the hill is 10 m s^{-1} and at the top it is 5 m s^{-1} . There is a resistance to motion, and the work done against this resistance as the cyclist ascends the hill is 2000 J. The cyclist exerts a constant force of magnitude $F \text{ N}$ in the direction of motion. Find F . [5]

82. [9709/w19/42/q4]

A lorry of mass 25 000 kg travels along a straight horizontal road. There is a constant force of 3000 N resisting the motion.

- (i) Find the power required to maintain a constant speed of 30 m s^{-1} . [2]

The lorry comes to a straight hill inclined at 2° to the horizontal. The driver switches off the engine of the lorry at the point A which is at the foot of the hill. Point B is further up the hill. The speeds of the lorry at A and B are 30 m s^{-1} and 25 m s^{-1} respectively. The resistance force is still 3000 N.

- (ii) Use an energy method to find the height of B above the level of A . [5]

83. [9709/w19/43/q2]

A train of mass 150 000 kg ascends a straight slope inclined at α° to the horizontal with a constant driving force of 16 000 N. At a point A on the slope the speed of the train is 45 m s^{-1} . Point B on the slope is 500 m beyond A . At B the speed of the train is 42 m s^{-1} . There is a resistance force acting on the train and the train does $4 \times 10^6 \text{ J}$ of work against this resistance force between A and B . Find the value of α . [5]

84. [9709/w19/43/q5]

A cyclist is travelling along a straight horizontal road. The total mass of the cyclist and his bicycle is 80 kg. His power output is a constant 240 W. His acceleration when he is travelling at 6 m s^{-1} is 0.3 m s^{-2} .

- (i) Show that the resistance to the cyclist's motion is 16 N. [3]
- (ii) Find the steady speed that the cyclist can maintain if his power output and the resistance force are both unchanged. [2]
- (iii) The cyclist later ascends a straight hill inclined at 3° to the horizontal. His power output and the resistance force are still both unchanged. Find his acceleration when he is travelling at 4 m s^{-1} . [3]

85. [9709/m18/42/q3]

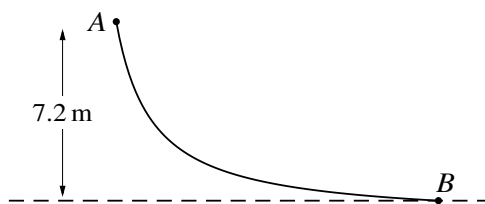

A girl, of mass 40 kg, slides down a slide in a water park. The girl starts at the point A and slides to the point B which is 7.2 metres vertically below the level of A , as shown in the diagram.

- (i) Given that the slide is smooth and that the girl starts from rest at A , find the speed of the girl at B . [2]
- (ii) It is given instead that the slide is rough. On one occasion the girl starts from rest at A and reaches B with a speed of 10 m s^{-1} . On another occasion the girl is pushed from A with an initial speed $V \text{ m s}^{-1}$ and reaches B with speed 11 m s^{-1} . Given that the work done against friction is the same on both occasions, find V . [3]

86. [9709/m18/42/q6]

A car of mass 1200 kg has a greatest possible constant speed of 60 m s^{-1} along a straight level road. When the car is travelling at a speed of $v \text{ m s}^{-1}$ there is a resistive force of magnitude $35v \text{ N}$.

- (i) Find the greatest possible power of the car. [2]
- (ii) The car travels along a straight level road. Show that, at an instant when its speed is 30 m s^{-1} , the greatest possible acceleration of the car is 2.625 m s^{-2} . [3]
- (iii) The car travels at a constant speed up a hill inclined at an angle of $\sin^{-1}\left(\frac{7}{48}\right)$ to the horizontal. Find the greatest possible speed of the car. [5]

87. [9709/s18/41/q6]

A car has mass 1250 kg.

- (i) The car is moving along a straight level road at a constant speed of 36 m s^{-1} and is subject to a constant resistance of magnitude 850 N. Find, in kW, the rate at which the engine of the car is working. [2]
- (ii) The car travels at a constant speed up a hill and is subject to the same resistance as in part (i). The hill is inclined at an angle of θ° to the horizontal, where $\sin \theta^\circ = 0.1$, and the engine is working at 63 kW. Find the speed of the car. [3]
- (iii) The car descends the same hill with the engine of the car working at a constant rate of 20 kW. The resistance is not constant. The initial speed of the car is 20 m s^{-1} . Eight seconds later the car has speed 24 m s^{-1} and has moved 176 m down the hill. Use an energy method to find the total work done against the resistance during the eight seconds. [5]

88. [9709/s18/42/q1]

A man has mass 80 kg. He runs along a horizontal road against a constant resistance force of magnitude P N. The total work done by the man in increasing his speed from 4 m s^{-1} to 5.5 m s^{-1} while running a distance of 60 metres is 1200 J. Find the value of P . [4]

89. [9709/s18/42/q2]

A train of mass 240 000 kg travels up a slope inclined at an angle of 4° to the horizontal. There is a constant resistance of magnitude 18 000 N acting on the train. At an instant when the speed of the train is 15 m s^{-1} its deceleration is 0.2 m s^{-2} . Find the power of the engine of the train. [4]

90. [9709/s18/43/q6]

A car of mass 1400 kg travelling at a speed of $v \text{ m s}^{-1}$ experiences a resistive force of magnitude $40v \text{ N}$. The greatest possible constant speed of the car along a straight level road is 56 m s^{-1} .

- (i) Find, in kW, the greatest possible power of the car's engine. [2]
- (ii) Find the greatest possible acceleration of the car at an instant when its speed on a straight level road is 32 m s^{-1} . [3]
- (iii) The car travels down a hill inclined at an angle of θ° to the horizontal at a constant speed of 50 m s^{-1} . The power of the car's engine is 60 kW. Find the value of θ . [4]

91. [9709/w18/41/q2]

A high-speed train of mass 490 000 kg is moving along a straight horizontal track at a constant speed of 85 m s^{-1} . The engines are supplying 4080 kW of power.

(i) Show that the resistance force is 48 000 N. [1]

(ii) The train comes to a hill inclined at an angle θ° above the horizontal, where $\sin \theta^\circ = \frac{1}{200}$. Given that the resistance force is unchanged, find the power required for the train to keep moving at the same constant speed of 85 m s^{-1} . [3]

92. [9709/w18/41/q3]

A van of mass 2500 kg descends a hill of length 0.4 km inclined at 4° to the horizontal. There is a constant resistance to motion of 600 N and the speed of the van increases from 20 m s^{-1} to 30 m s^{-1} as it descends the hill. Find the work done by the van's engine as it descends the hill. [5]

93. [9709/w18/42/q6]

A car of mass 1200 kg is driving along a straight horizontal road at a constant speed of 15 m s^{-1} . There is a constant resistance to motion of 350 N.

- (i) Find the power of the car's engine. [1]

The car comes to a hill inclined at 1° to the horizontal, still travelling at 15 m s^{-1} .

- (ii) The car starts to descend the hill with reduced power and with an acceleration of 0.12 m s^{-2} . Given that there is no change in the resistance force, find the new power of the car's engine at the instant when it starts to descend the hill. [3]
- (iii) When the car is travelling at 20 m s^{-1} down the hill, the power is cut off and the car gradually slows down. Assuming that the resistance force remains 350 N, find the distance travelled from the moment when the power is cut off until the speed of the car is reduced to 18 m s^{-1} . [4]

94. [9709/w18/42/q7]

A particle of mass 0.3 kg is released from rest above a tank containing water. The particle falls vertically, taking 0.8 s to reach the water surface. There is no instantaneous change of speed when the particle enters the water. The depth of water in the tank is 1.25 m. The water exerts a force on the particle resisting its motion. The work done against this resistance force from the instant that the particle enters the water until it reaches the bottom of the tank is 1.2 J.

- (i) Use an energy method to find the speed of the particle when it reaches the bottom of the tank. [4]

When the particle reaches the bottom of the tank, it bounces back vertically upwards with initial speed 7 m s^{-1} . As the particle rises through the water, it experiences a constant resistance force of 1.8 N. The particle comes to instantaneous rest t seconds after it bounces on the bottom of the tank.

- (ii) Find the value of t . [7]

95. [9709/w18/43/q3]

A particle of mass 1.2 kg moves in a straight line AB . It is projected with speed 7.5 m s^{-1} from A towards B and experiences a resistance force. The work done against this resistance force in moving from A to B is 25 J .

(i) Given that AB is horizontal, find the speed of the particle at B . [2]

(ii) It is given instead that AB is inclined at 30° below the horizontal and that the speed of the particle at B is 9 m s^{-1} . The work done against the resistance force remains the same. Find the distance AB . [3]

96. [9709/w18/43/q6]

A van of mass 3200 kg travels along a horizontal road. The power of the van's engine is constant and equal to 36 kW, and there is a constant resistance to motion acting on the van.

- (i) When the speed of the van is 20 m s^{-1} , its acceleration is 0.2 m s^{-2} . Find the resistance force. [3]

When the van is travelling at 30 m s^{-1} , it begins to ascend a hill inclined at 1.5° to the horizontal. The power is increased and the resistance force is still equal to the value found in part (i).

- (ii) Find the power required to maintain this speed of 30 m s^{-1} . [3]
- (iii) The engine is now stopped, with the van still travelling at 30 m s^{-1} , and the van decelerates to rest. Find the distance the van moves up the hill from the point at which the engine is stopped until it comes to rest. [4]

97. [9709/m17/42/q1]

A particle of mass 0.4 kg is projected with a speed of 12 m s^{-1} up a line of greatest slope of a smooth plane inclined at 30° to the horizontal.

- (i) Find the initial kinetic energy of the particle. [1]
- (ii) Use an energy method to find the distance the particle moves up the plane before coming to instantaneous rest. [3]

98. [9709/m17/42/q4]

A car of mass 900 kg is moving on a straight horizontal road $ABCD$. There is a constant resistance of magnitude 800 N in the sections AB and BC , and a constant resistance of magnitude R N in the section CD . The power of the car's engine is a constant 36 kW.

- (i) The car moves from A to B at a constant speed in 120 s. Find the speed of the car and the distance AB . [3]

The car's engine is switched off at B .

- (ii) The distance BC is 450 m. Find the speed of the car at C . [3]
- (iii) The car comes to rest at D . The distance AD is 6637.5 m. Find the deceleration of the car and the value of R . [4]

99. [9709/s17/41/q1]

A particle of mass 0.6 kg is dropped from a height of 8 m above the ground. The speed of the particle at the instant before hitting the ground is 10 m s^{-1} . Find the work done against air resistance. [3]

100. [9709/s17/41/q4]

A car of mass 800 kg is moving up a hill inclined at θ° to the horizontal, where $\sin \theta = 0.15$. The initial speed of the car is 8 m s^{-1} . Twelve seconds later the car has travelled 120 m up the hill and has speed 14 m s^{-1} .

- (i) Find the change in the kinetic energy and the change in gravitational potential energy of the car. [3]
- (ii) The engine of the car is working at a constant rate of 32 kW. Find the total work done against the resistive forces during the twelve seconds. [3]

101. [9709/s17/42/q1]

One end of a light inextensible string is attached to a block. The string makes an angle of θ° with the horizontal. The tension in the string is 20 N. The string pulls the block along a horizontal surface at a constant speed of 1.5 m s^{-1} for 12 s. The work done by the tension in the string is 50 J. Find θ . [3]

102. [9709/s17/42/q2]

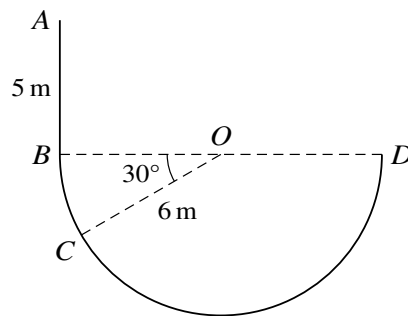

The diagram shows a wire $ABCD$ consisting of a straight part AB of length 5 m and a part BCD in the shape of a semicircle of radius 6 m and centre O . The diameter BD of the semicircle is horizontal and AB is vertical. A small ring is threaded onto the wire and slides along the wire. The ring starts from rest at A . The part AB of the wire is rough, and the ring accelerates at a constant rate of 2.5 m s^{-2} between A and B .

(i) Show that the speed of the ring as it reaches B is 5 m s^{-1} . [1]

The part BCD of the wire is smooth. The mass of the ring is 0.2 kg.

(ii) (a) Find the speed of the ring at C , where angle $BOC = 30^\circ$. [4]

(b) Find the greatest speed of the ring. [2]

103. [9709/s17/42/q4]

A car of mass 1200 kg is moving on a straight road against a constant force of 850 N resisting the motion.

- (i) On a part of the road that is horizontal, the car moves with a constant speed of 42 m s^{-1} .
- (a) Calculate, in kW, the power developed by the engine of the car. [2]
- (b) Given that this power is suddenly increased by 6 kW, find the instantaneous acceleration of the car. [3]
- (ii) On a part of the road that is inclined at θ° to the horizontal, the car moves up the hill at a constant speed of 24 m s^{-1} , with the engine working at 80 kW. Find θ . [4]

104. [9709/s17/43/q1]

A man pushes a wheelbarrow of mass 25 kg along a horizontal road with a constant force of magnitude 35 N at an angle of 20° below the horizontal. There is a constant resistance to motion of 15 N. The wheelbarrow moves a distance of 12 m from rest.

(i) Find the work done by the man. [2]

(ii) Find the speed attained by the wheelbarrow after 12 m. [3]

105. [9709/s17/43/q6]

A car of mass 1200 kg is travelling along a horizontal road.

(i) It is given that there is a constant resistance to motion.

(a) The engine of the car is working at 16 kW while the car is travelling at a constant speed of 40 m s^{-1} . Find the resistance to motion. [2]

(b) The power is now increased to 22.5 kW. Find the acceleration of the car at the instant it is travelling at a speed of 45 m s^{-1} . [3]

(ii) It is given instead that the resistance to motion of the car is $(590 + 2v) \text{ N}$ when the speed of the car is $v \text{ m s}^{-1}$. The car travels at a constant speed with the engine working at 16 kW. Find this speed. [3]

106. [9709/w17/41/q2]

A tractor of mass 3700 kg is travelling along a straight horizontal road at a constant speed of 12 m s^{-1} . The total resistance to motion is 1150 N.

(i) Find the power output of the tractor's engine. [1]

The tractor comes to a hill inclined at 4° above the horizontal. The power output is increased to 25 kW and the resistance to motion is unchanged.

(ii) Find the deceleration of the tractor at the instant it begins to climb the hill. [3]

(iii) Find the constant speed that the tractor could maintain on the hill when working at this power. [2]

107. [9709/w17/41/q3]

A roller-coaster car (including passengers) has a mass of 840 kg. The roller-coaster ride includes a section where the car climbs a straight ramp of length 8 m inclined at 30° above the horizontal. The car then immediately descends another ramp of length 10 m inclined at 20° below the horizontal. The resistance to motion acting on the car is 640 N throughout the motion.

- (i) Find the total work done against the resistance force as the car ascends the first ramp and descends the second ramp. [2]
- (ii) The speed of the car at the bottom of the first ramp is 14 m s^{-1} . Use an energy method to find the speed of the car when it reaches the bottom of the second ramp. [4]

108. [9709/w17/42/q5]

A cyclist is riding up a straight hill inclined at an angle α to the horizontal, where $\sin \alpha = 0.04$. The total mass of the bicycle and rider is 80 kg. The cyclist is riding at a constant speed of 4 m s^{-1} . There is a force resisting the motion. The work done by the cyclist against this resistance force over a distance of 25 m is 600 J.

- (i) Find the power output of the cyclist. [4]

The cyclist reaches the top of the hill, where the road becomes horizontal, with speed 4 m s^{-1} . The cyclist continues to work at the same rate on the horizontal part of the road.

- (ii) Find the speed of the cyclist 10 seconds after reaching the top of the hill, given that the work done by the cyclist during this period against the resistance force is 1200 J. [4]

109. [9709/w17/43/q2]

A lorry of mass 7850 kg travels on a straight hill which is inclined at an angle of 3° to the horizontal. There is a constant resistance to motion of 1480 N.

- (i) Find the power of the lorry's engine when the lorry is going up the hill at a constant speed of 10 m s^{-1} . [3]
- (ii) Find the power of the lorry's engine at an instant when the lorry is going down the hill at a speed of 15 m s^{-1} with an acceleration of 0.8 m s^{-2} . [3]

110. [9709/w17/43/q7]

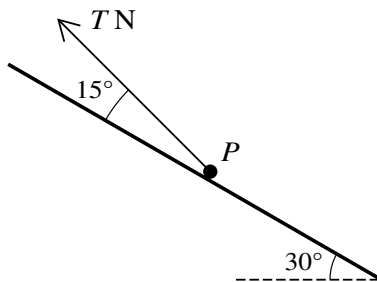

A particle P of mass 0.2 kg rests on a rough plane inclined at 30° to the horizontal. The coefficient of friction between the particle and the plane is 0.3 . A force of magnitude T N acts upwards on P at 15° above a line of greatest slope of the plane (see diagram).

- (i) Find the least value of T for which the particle remains at rest. [6]

The force of magnitude T N is now removed. A new force of magnitude 0.25 N acts on P up the plane, parallel to a line of greatest slope of the plane. Starting from rest, P slides down the plane. After moving a distance of 3 m, P passes through the point A .

- (ii) Use an energy method to find the speed of P at A . [5]

111. [9709/m16/42/q2]

A constant resistance of magnitude 1350 N acts on a car of mass 1200 kg.

- (i) The car is moving along a straight level road at a constant speed of 32 m s^{-1} . Find, in kW, the rate at which the engine of the car is working. [2]
- (ii) The car travels at a constant speed up a hill inclined at an angle of θ to the horizontal, where $\sin \theta = 0.1$, with the engine working at 76.5 kW. Find this speed. [3]

112. [9709/s16/41/q2]

A box of mass 25 kg is pulled, at a constant speed, a distance of 36 m up a rough plane inclined at an angle of 20° to the horizontal. The box moves up a line of greatest slope against a constant frictional force of 40 N. The force pulling the box is parallel to the line of greatest slope. Find

- (i) the work done against friction, [1]
- (ii) the change in gravitational potential energy of the box, [2]
- (iii) the work done by the pulling force. [2]

113. [9709/s16/41/q3]

A car of mass 1000 kg is moving along a straight horizontal road against resistances of total magnitude 300 N.

- (i) Find, in kW, the rate at which the engine of the car is working when the car has a constant speed of 40 m s^{-1} . [3]
- (ii) Find the acceleration of the car when its speed is 25 m s^{-1} and the engine is working at 90% of the power found in part (i). [3]

114. [9709/s16/41/q7]

A particle of mass 30 kg is on a plane inclined at an angle of 20° to the horizontal. Starting from rest, the particle is pulled up the plane by a force of magnitude 200 N acting parallel to a line of greatest slope.

(i) Given that the plane is smooth, find

(a) the acceleration of the particle, [2]

(b) the change in kinetic energy after the particle has moved 12 m up the plane. [2]

(ii) It is given instead that the plane is rough and the coefficient of friction between the particle and the plane is 0.12.

(a) Find the acceleration of the particle. [4]

(b) The direction of the force of magnitude 200 N is changed, and the force now acts at an angle of 10° above the line of greatest slope. Find the acceleration of the particle. [4]

115. [9709/s16/42/q3]

A particle of mass 8 kg is projected with a speed of 5 m s^{-1} up a line of greatest slope of a rough plane inclined at an angle α to the horizontal, where $\sin \alpha = \frac{5}{13}$. The motion of the particle is resisted by a constant frictional force of magnitude 15 N. The particle comes to instantaneous rest after travelling a distance x m up the plane.

(i) Express the change in gravitational potential energy of the particle in terms of x . [2]

(ii) Use an energy method to find x . [4]

116. [9709/s16/42/q6]

A car of mass 1100 kg is moving on a road against a constant force of 1550 N resisting the motion.

- (i) The car moves along a straight horizontal road at a constant speed of 40 m s^{-1} .
- (a) Calculate, in kW, the power developed by the engine of the car. [2]
- (b) Given that this power is suddenly decreased by 22 kW, find the instantaneous deceleration of the car. [3]
- (ii) The car now travels at constant speed up a straight road inclined at 8° to the horizontal, with the engine working at 80 kW. Assuming the resistance force remains the same, find this constant speed. [3]

117. [9709/s16/43/q1]

A particle of mass 8 kg is pulled at a constant speed a distance of 20 m up a rough plane inclined at an angle of 30° to the horizontal by a force acting along a line of greatest slope.

- (i) Find the change in gravitational potential energy of the particle. [2]
- (ii) The total work done against gravity and friction is 1146 J. Find the frictional force acting on the particle. [2]

118. [9709/s16/43/q5]

The motion of a car of mass 1400 kg is resisted by a constant force of magnitude 650 N.

- (i) Find the constant speed of the car on a horizontal road, assuming that the engine works at a rate of 20 kW. [2]
- (ii) The car is travelling at a constant speed of 10 m s^{-1} up a hill inclined at an angle of θ to the horizontal, where $\sin \theta = \frac{1}{7}$. Find the power of the car's engine. [3]
- (iii) The car descends the same hill with the engine working at 80% of the power found in part (ii). Find the acceleration of the car at an instant when the speed is 20 m s^{-1} . [3]

119. [9709/w16/41/q5]

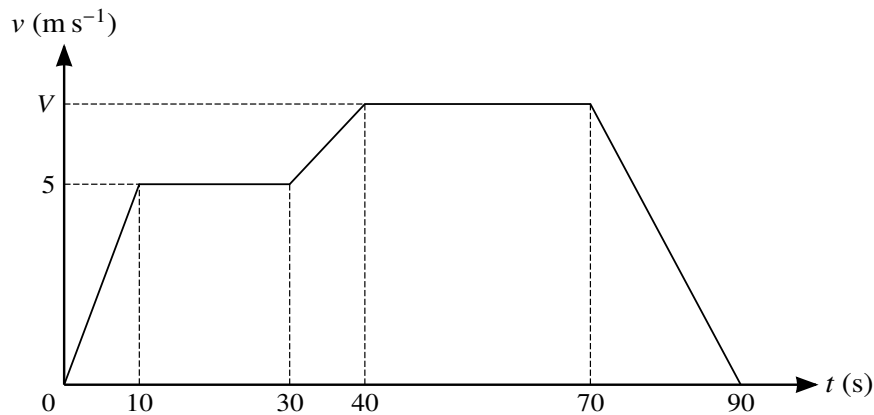

The diagram shows a velocity-time graph which models the motion of a cyclist. The graph consists of five straight line segments. The cyclist accelerates from rest to a speed of 5 m s^{-1} over a period of 10 s, and then travels at this speed for a further 20 s. The cyclist then descends a hill, accelerating to speed $V \text{ m s}^{-1}$ over a period of 10 s. This speed is maintained for a further 30 s. The cyclist then decelerates to rest over a period of 20 s.

- (i) Find the acceleration of the cyclist during the first 10 seconds. [1]
- (ii) Show that the total distance travelled by the cyclist in the 90 seconds of motion may be expressed as $(45V + 150) \text{ m}$. Hence find V , given that the total distance travelled by the cyclist is 465 m. [3]
- (iii) The combined mass of the cyclist and the bicycle is 80 kg. The cyclist experiences a constant resistance to motion of 20 N. Use an energy method to find the vertical distance which the cyclist descends during the downhill section from $t = 30$ to $t = 40$, assuming that the cyclist does no work during this time. [4]

120. [9709/w16/41/q6]

A block of mass 25 kg is pulled along horizontal ground by a force of magnitude 50 N inclined at 10° above the horizontal. The block starts from rest and travels a distance of 20 m. There is a constant resistance force of magnitude 30 N opposing motion.

- (i) Find the work done by the pulling force. [2]
- (ii) Use an energy method to find the speed of the block when it has moved a distance of 20 m. [2]
- (iii) Find the greatest power exerted by the 50 N force. [2]

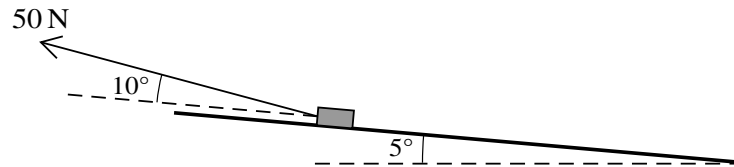

After the block has travelled the 20 m, it comes to a plane inclined at 5° to the horizontal. The force of 50 N is now inclined at an angle of 10° to the plane and pulls the block directly up the plane (see diagram). The resistance force remains 30 N.

- (iv) Find the time it takes for the block to come to rest from the instant when it reaches the foot of the inclined plane. [4]

121. [9709/w16/42/q4]

A girl on a sledge starts, with a speed of 5 m s^{-1} , at the top of a slope of length 100 m which is at an angle of 20° to the horizontal. The sledge slides directly down the slope.

- (i) Given that there is no resistance to the sledge's motion, find the speed of the sledge at the bottom of the slope. [3]
- (ii) It is given instead that the sledge experiences a resistance to motion such that the total work done against the resistance is 8500 J , and the speed of the sledge at the bottom of the slope is 21 m s^{-1} . Find the total mass of the girl and the sledge. [3]

122. [9709/w16/42/q6]

A van of mass 3000 kg is pulling a trailer of mass 500 kg along a straight horizontal road at a constant speed of 25 m s^{-1} . The system of the van and the trailer is modelled as two particles connected by a light inextensible cable. There is a constant resistance to motion of 300 N on the van and 100 N on the trailer.

(i) Find the power of the van's engine. [2]

(ii) Write down the tension in the cable. [1]

The van reaches the bottom of a hill inclined at 4° to the horizontal with speed 25 m s^{-1} . The power of the van's engine is increased to 25 000 W.

(iii) Assuming that the resistance forces remain the same, find the new tension in the cable at the instant when the speed of the van up the hill is 20 m s^{-1} . [5]

123. [9709/w16/43/q1]

A crane is used to raise a block of mass 50 kg vertically upwards at constant speed through a height of 3.5 m. There is a constant resistance to motion of 25 N.

(i) Find the work done by the crane. [3]

(ii) Given that the time taken to raise the block is 2 s, find the power of the crane. [2]

124. [9709/w16/43/q6]

A cyclist is cycling with constant power of 160 W along a horizontal straight road. There is a constant resistance to motion of 20 N. At an instant when the cyclist's speed is 5 m s^{-1} , his acceleration is 0.15 m s^{-2} .

- (i) Show that the total mass of the cyclist and bicycle is 80 kg. [3]

The cyclist comes to a hill inclined at 2° to the horizontal. When the cyclist starts climbing the hill, he increases his power to a constant 300 W. The resistance to motion remains 20 N.

- (ii) Show that the steady speed up the hill which the cyclist can maintain when working at this power is 6.26 m s^{-1} , correct to 3 significant figures. [2]
- (iii) Find the acceleration at an instant when the cyclist is travelling at 90% of the speed in part (ii). [4]

125. [9709/w16/43/q7]

A box of mass 50 kg is at rest on a plane inclined at 10° to the horizontal.

- (i) Find an inequality for the coefficient of friction between the box and the plane. [2]

In fact the coefficient of friction between the box and the plane is 0.19.

- (ii) A girl pushes the box with a force of 50 N, acting down a line of greatest slope of the plane, for a distance of 5 m. She then stops pushing. Use an energy method to find the speed of the box when it has travelled a further 5 m. [5]

The box then comes to a plane inclined at 20° below the horizontal. The box moves down a line of greatest slope of this plane. The coefficient of friction is still 0.19 and the girl is not pushing the box.

- (iii) Find the acceleration of the box. [2]

126. [9709/s15/41/q1]

A block B of mass 2.7 kg is pulled at constant speed along a straight line on a rough horizontal floor. The pulling force has magnitude 25 N and acts at an angle of θ above the horizontal. The normal component of the contact force acting on B has magnitude 20 N .

(i) Show that $\sin \theta = 0.28$. [2]

(ii) Find the work done by the pulling force in moving the block a distance of 5 m . [2]

127. [9709/s15/41/q4]

A lorry of mass 14 000 kg moves along a road starting from rest at a point O . It reaches a point A , and then continues to a point B which it reaches with a speed of 24 m s^{-1} . The part OA of the road is straight and horizontal and has length 400 m. The part AB of the road is straight and is inclined downwards at an angle of θ° to the horizontal and has length 300 m.

- (i) For the motion from O to B , find the gain in kinetic energy of the lorry and express its loss in potential energy in terms of θ . [3]

The resistance to the motion of the lorry is 4800 N and the work done by the driving force of the lorry from O to B is 5000 kJ.

- (ii) Find the value of θ . [3]

128. [9709/s15/41/q5]

A cyclist and her bicycle have a total mass of 84 kg. She works at a constant rate of P W while moving on a straight road which is inclined to the horizontal at an angle θ , where $\sin \theta = 0.1$. When moving uphill, the cyclist's acceleration is 1.25 m s^{-2} at an instant when her speed is 3 m s^{-1} . When moving downhill, the cyclist's acceleration is 1.25 m s^{-2} at an instant when her speed is 10 m s^{-1} . The resistance to the cyclist's motion, whether the cyclist is moving uphill or downhill, is R N. Find the values of P and R . [8]

129. [9709/s15/42/q1]

One end of a light inextensible string is attached to a block. The string makes an angle of 60° above the horizontal and is used to pull the block in a straight line on a horizontal floor with acceleration 0.5 m s^{-2} . The tension in the string is 8 N . The block starts to move with speed 0.3 m s^{-1} . For the first 5 s of the block's motion, find

(i) the distance travelled, [2]

(ii) the work done by the tension in the string. [2]

130. [9709/s15/42/q2]

The total mass of a cyclist and his cycle is 80 kg. The resistance to motion is zero.

- (i) The cyclist moves along a horizontal straight road working at a constant rate of P W. Find the value of P given that the cyclist's speed is 5 m s^{-1} when his acceleration is 1.2 m s^{-2} . [2]
- (ii) The cyclist moves up a straight hill inclined at an angle α , where $\sin \alpha = 0.035$. Find the acceleration of the cyclist at an instant when he is working at a rate of 450 W and has speed 3.6 m s^{-1} . [3]

131. [9709/s15/42/q3]

A plane is inclined at an angle of $\sin^{-1}\left(\frac{1}{8}\right)$ to the horizontal. A and B are two points on the same line of greatest slope with A higher than B . The distance AB is 12 m. A small object P of mass 8 kg is released from rest at A and slides down the plane, passing through B with speed 4.5 m s^{-1} . For the motion of P from A to B , find

- (i) the increase in kinetic energy of P and the decrease in potential energy of P , [3]
- (ii) the magnitude of the constant resisting force that opposes the motion of P . [2]

132. [9709/s15/43/q1]

A block is pulled along a horizontal floor by a horizontal rope. The tension in the rope is 500 N and the block moves at a constant speed of 2.75 m s^{-1} . Find the work done by the tension in 40 s and find the power applied by the tension. [4]

133. [9709/s15/43/q3]

A car of mass 860 kg travels along a straight horizontal road. The power provided by the car's engine is P W and the resistance to the car's motion is R N. The car passes through one point with speed 4.5 m s^{-1} and acceleration 4 m s^{-2} . The car passes through another point with speed 22.5 m s^{-1} and acceleration 0.3 m s^{-2} . Find the values of P and R . [6]

134. [9709/w15/41/q1]

A weightlifter performs an exercise in which he raises a mass of 200 kg from rest vertically through a distance of 0.7 m and holds it at that height.

- (i) Find the work done by the weightlifter. [2]
- (ii) Given that the time taken to raise the mass is 1.2 s, find the average power developed by the weightlifter. [2]

135. [9709/w15/41/q3]

A lorry of mass 24 000 kg is travelling up a hill which is inclined at 3° to the horizontal. The power developed by the lorry's engine is constant, and there is a constant resistance to motion of 3200 N.

- (i) When the speed of the lorry is 25 m s^{-1} , its acceleration is 0.2 m s^{-2} . Find the power developed by the lorry's engine. [4]
- (ii) Find the steady speed at which the lorry moves up the hill if the power is 500 kW and the resistance remains 3200 N. [2]

136. [9709/w15/42/q4]

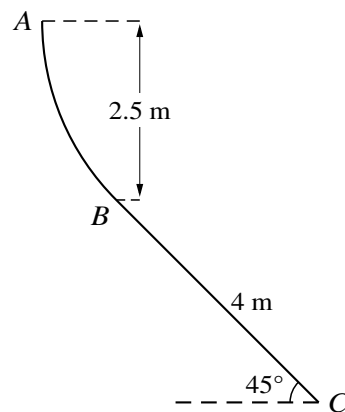

The diagram shows a vertical cross-section ABC of a surface. The part of the surface containing AB is smooth and A is 2.5 m above the level of B . The part of the surface containing BC is rough and is at 45° to the horizontal. The distance BC is 4 m (see diagram). A particle P of mass 0.2 kg is released from rest at A and moves in contact with the curve AB and then with the straight line BC . The coefficient of friction between P and the part of the surface containing BC is 0.4. Find the speed with which P reaches C . [6]

137. [9709/w15/42/q7]

A car of mass 1600 kg moves with constant power 14 kW as it travels along a straight horizontal road. The car takes 25 s to travel between two points *A* and *B* on the road.

- (i) Find the work done by the car's engine while the car travels from *A* to *B*. [2]

The resistance to the car's motion is constant and equal to 235 N. The car has accelerations at *A* and *B* of 0.5 m s^{-2} and 0.25 m s^{-2} respectively. Find

- (ii) the gain in kinetic energy by the car in moving from *A* to *B*, [5]
(iii) the distance *AB*. [3]

138. [9709/w15/43/q5]

A cyclist and his bicycle have a total mass of 90 kg. The cyclist starts to move with speed 3 m s^{-1} from the top of a straight hill, of length 500 m, which is inclined at an angle of $\sin^{-1} 0.05$ to the horizontal. The cyclist moves with constant acceleration until he reaches the bottom of the hill with speed 5 m s^{-1} . The cyclist generates 420 W of power while moving down the hill. The resistance to the motion of the cyclist and his bicycle, $R \text{ N}$, and the cyclist's speed, $v \text{ m s}^{-1}$, both vary.

(i) Show that $R = \frac{420}{v} + 43.56$. [5]

(ii) Find the cyclist's speed at the mid-point of the hill. Hence find the decrease in the value of R when the cyclist moves from the top of the hill to the mid-point of the hill, and when the cyclist moves from the mid-point of the hill to the bottom of the hill. [3]

139. [9709/w15/43/q7]

A straight hill AB has length 400 m with A at the top and B at the bottom and is inclined at an angle of 4° to the horizontal. A straight horizontal road BC has length 750 m. A car of mass 1250 kg has a speed of 5 m s^{-1} at A when starting to move down the hill. While moving down the hill the resistance to the motion of the car is 2000 N and the driving force is constant. The speed of the car on reaching B is 8 m s^{-1} .

- (i) By using work and energy, find the driving force of the car. [5]

On reaching B the car moves along the road BC . The driving force is constant and twice that when the car was on the hill. The resistance to the motion of the car continues to be 2000 N. Find

- (ii) the acceleration of the car while moving from B to C , [3]
(iii) the power of the car's engine as the car reaches C . [3]

Chapter 8

Momentum and collision

1. [9709/m25/42/q5]

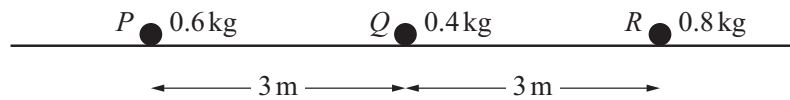

Three particles P , Q and R , of masses 0.6 kg , 0.4 kg and 0.8 kg respectively, are at rest in a straight line on a smooth horizontal plane. The distance from P to Q is 3 m , and the distance from Q to R is also 3 m (see diagram). P is projected directly towards Q with speed 3 m s^{-1} . After P and Q collide, P continues to move in the same direction with speed 1.5 m s^{-1} .

(a) Find the speed of Q after the collision. [2]

In the subsequent collision between Q and R , these particles coalesce.

(b) Find the speed of the combined particle after this collision. [1]

(c) Find the time that it takes from when P is initially projected until the instant at which P collides with the combined particle. [4]

2. [9709/s25/41/q5]

When a particle P of mass m kg has speed u ms⁻¹, its momentum is 4 N s and its kinetic energy is 16 J.

(a) Find the value of m and the value of u . [3]

P is now projected on a smooth horizontal surface with speed v ms⁻¹ directly towards a particle Q of mass 1.25 kg which is stationary. After P and Q collide, the velocity of P is w ms⁻¹ and the velocity of Q is $2w$ ms⁻¹. The loss of kinetic energy in the collision is 25 J.

(b) Find the value of v and the value of w . [4]

3. [9709/s25/42/q2]

Two particles P and Q , of masses 0.2 kg and 0.1 kg respectively, are free to move in a straight line on a smooth horizontal plane. P is projected towards Q with speed 5 ms^{-1} . At the same instant, Q is projected away from P with speed 2 ms^{-1} . When P collides with Q , the particles coalesce.

Find the kinetic energy lost during the collision.

[4]

4. [9709/s25/43/q1]

Two particles P and Q , of masses 0.1 kg and 0.3 kg respectively, are at rest on a smooth horizontal plane. P is projected directly towards Q with speed $4u\text{ ms}^{-1}$. At the same instant, Q is projected directly towards P with speed $u\text{ ms}^{-1}$. After P and Q collide, P moves with speed 2 ms^{-1} and Q moves with speed 4 ms^{-1} .

(a) Find the two possible values of u . [3]

(b) Find the largest possible loss of kinetic energy in the collision. [2]

5. [9709/s25/45/q2]

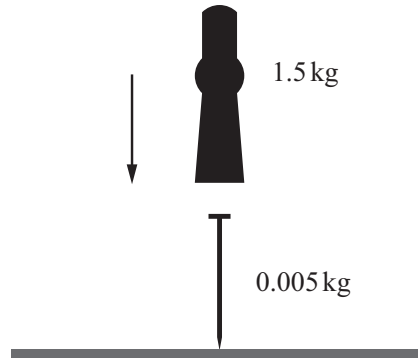

A machine for driving a nail into a block of wood causes a hammerhead to drop vertically onto the top of the nail. The mass of the hammerhead is 1.5 kg and the mass of the nail is 0.005 kg (see diagram). The hammerhead hits the nail with speed 32 m s^{-1} and remains in contact with the nail after the impact.

(a) Calculate the speed with which the combined hammerhead and nail move immediately after the impact. Give your answer correct to 3 decimal places. [2]

There is a constant force resisting the motion of magnitude 25 000 N.

(b) Calculate the distance the nail is driven into the wood. [3]

6. [9709/w25/41/q2]

Two particles, P and Q , of masses 3 kg and 5 kg respectively, are at rest on a smooth horizontal plane. P is projected at a speed of 4 m s^{-1} directly towards Q . After P and Q collide, P has speed 1 m s^{-1} .

(a) Find the two possible speeds of Q after the collision. [3]

It is given that $\lambda \text{ J}$ of kinetic energy, where $\lambda > 0$, is lost during the collision.

(b) Find the value of λ . [2]

7. [9709/w25/41/q6]

A particle A of mass 2.5 kg is released from rest from the top of a smooth plane, which makes an angle of $\sin^{-1} 0.2$ with the horizontal. The particle A collides 2 seconds later with a particle B , of mass 3 kg , which is moving up a line of greatest slope of the plane. The speed of B immediately before the collision is 3.5 m s^{-1} . Immediately after the collision, B has a velocity of 0.5 m s^{-1} down the plane.

Find the distance A moves up the plane after the collision.

[6]

8. [9709/w25/42/q4]

A particle P of mass 0.1 kg is projected vertically upwards with speed 30 m s^{-1} from horizontal ground. At the same instant a particle Q of mass 0.4 kg is projected vertically upwards with speed 10 m s^{-1} from a height of 15 m above the ground. P and Q move in the same vertical line.

(a) Find the height above the ground at which P and Q collide. [4]

When P and Q collide, they coalesce.

(b) Find the speed of the combined particle at the instant that it reaches the ground. [5]

9. [9709/w25/43/q6]

Particle P of mass m kg and particle Q of mass 2 kg are free to move on a smooth horizontal plane. P and Q are moving directly towards each other with speeds u m s⁻¹ and $3u$ m s⁻¹ respectively. P and Q collide and the direction of motion of each particle is reversed by the collision. Immediately after the collision the speed of P is $\frac{u}{3}$ m s⁻¹.

- (a) Find, in terms of m and u , an expression for the velocity of Q after the collision and hence show that $m > 4.5$. [3]

.....
 Q subsequently hits a vertical wall which is perpendicular to the direction of motion of Q . The speed of Q after the impact with the wall is a quarter of its speed before the impact with the wall. There are no further collisions between P and Q .

- (b) Given that m is an integer, determine the largest possible value of m . [4]

10. [9709/m24/42/q7]

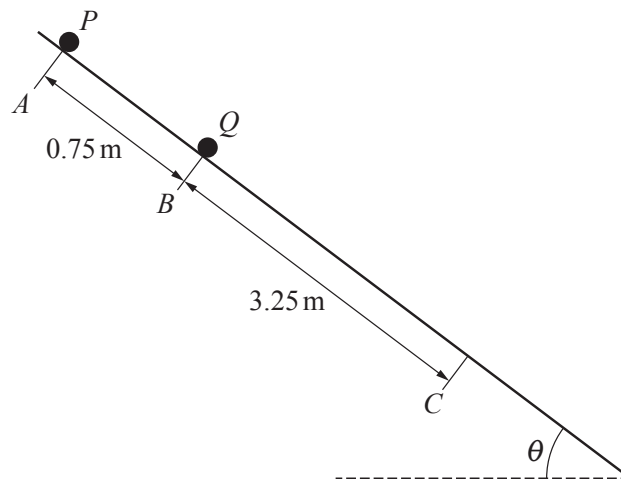

The diagram shows two particles P and Q which lie on a line of greatest slope of a plane ABC . Particles P and Q are each of mass m kg. The plane is inclined at an angle θ to the horizontal, where $\sin \theta = 0.6$. The length of AB is 0.75 m and the length of BC is 3.25 m. The section AB of the plane is smooth and the section BC is rough. The coefficient of friction between each particle and the section BC is 0.25. Particle P is released from rest at A . At the same instant, particle Q is released from rest at B .

- (a) Verify that particle P reaches B 0.5 s after it is released, with speed 3 m s^{-1} . [3]
 (b) Find the time that it takes from the instant the two particles are released until they collide. [4]

The two particles coalesce when they collide. The coefficient of friction between the combined particle and the plane is still 0.25.

- (c) Find the time that it takes from the instant the particles collide until the combined particle reaches C . [5]

11. [9709/s24/41/q7]

A particle P of mass 0.2 kg is projected vertically upwards from horizontal ground with speed 25 ms^{-1} .

(a) Show that the speed of P when it reaches 20 m above the ground is 15 ms^{-1} . [2]

When P reaches 20 m above the ground it collides with a second particle Q of mass 0.1 kg which is moving downwards at 20 ms^{-1} . P is brought to instantaneous rest in the collision.

(b) Find the velocity of Q immediately after the collision. [2]

When P reaches the ground it rebounds back directly upwards with half of the speed that it had immediately before hitting the ground.

(c) Find the height above the ground at which P and Q next collide. [6]

12. [9709/s24/42/q6]

Three particles A , B and C of masses 5 kg, 1 kg and 2 kg respectively lie at rest in that order on a straight smooth horizontal track XYZ . Initially A is at X , B is at Y and C is at Z . Particle A is projected towards B with a speed of 6 m s^{-1} and at the same instant C is projected towards B with a speed of $v \text{ m s}^{-1}$. In the subsequent motion, A collides and coalesces with B to form particle D . Particle D then collides and coalesces with C to form particle E and E moves towards Z .

(a) Show that after the second collision the speed of E is $\frac{15-v}{4} \text{ m s}^{-1}$. [3]

(b) The total loss of kinetic energy of the system due to the two collisions is 63 J.

Use the result from (a) to show that . [3]

(c) It is given that the distance XY is 36 m and the distance YZ is 98 m.

(i) Find the time between the two collisions. [4]

(ii) Find the time between the instant that A is projected from X and the instant that E reaches Z . [1]

13. [9709/s24/43/q1]

Two particles P and Q of masses 0.2 kg and 0.5 kg respectively are at rest on a smooth horizontal plane. Particle P is projected with a speed 6 m s^{-1} directly towards Q . After P and Q collide, P moves with a speed of 1 m s^{-1} .

Find the two possible speeds of Q after the collision.

[3]

14. [9709/w24/41/q5]

A particle, A , is projected vertically upwards from a point O with a speed of 80 m s^{-1} . One second later a second particle, B , with the same mass as A , is projected vertically upwards from O with a speed of 100 m s^{-1} . At time T s after the first particle is projected, the two particles collide and coalesce to form a particle C .

- (a) Show that $T = 3.5$. [4]
- (b) Find the height above O at which the particles collide. [1]
- (c) Find the time from A being projected until C returns to O . [5]

15. [9709/w24/42/q5]

Two particles, P and Q , of masses $2m$ kg and m kg respectively, are held at rest in the same vertical line. The heights of P and Q above horizontal ground are 1 m and 2 m respectively. P is projected vertically upwards with speed 2 m s^{-1} . At the same instant, Q is released from rest.

(a) Find the speed of each particle immediately before they collide. [4]

(b) It is given that immediately after the collision the downward speed of Q is 3.5 m s^{-1} .

Find the speed of P at the instant that it reaches the ground. [5]

16. [9709/w24/43/q4]

Two particles, A and B , of masses 3 kg and 6 kg respectively, lie on a smooth horizontal plane. Initially, B is at rest and A is moving towards B with speed 8 m s^{-1} . After A and B collide, A moves with speed 2 m s^{-1} .

Find the greater of the two possible total losses of kinetic energy due to the collision. [6]

17. [9709/m23/42/q7]

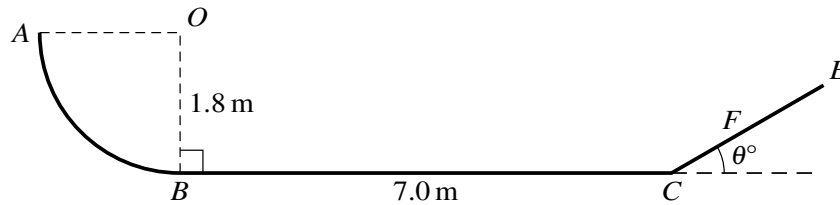

The diagram shows a smooth track which lies in a vertical plane. The section AB is a quarter circle of radius 1.8 m with centre O . The section BC is a horizontal straight line of length 7.0 m and OB is perpendicular to BC . The section CFE is a straight line inclined at an angle of θ° above the horizontal.

A particle P of mass 0.5 kg is released from rest at A . Particle P collides with a particle Q of mass 0.1 kg which is at rest at B . Immediately after the collision, the speed of P is 4 m s^{-1} in the direction BC . You should assume that P is moving horizontally when it collides with Q .

(a) Show that the speed of Q immediately after the collision is 10 m s^{-1} . [4]

When Q reaches C , it collides with a particle R of mass 0.4 kg which is at rest at C . The two particles coalesce. The combined particle comes instantaneously to rest at F . You should assume that there is no instantaneous change in speed as the combined particle leaves C , nor when it passes through C again as it returns down the slope.

(b) Given that the distance CF is 0.4 m , find the value of θ . [4]

(c) Find the distance from B at which P collides with the combined particle. [5]

18. [9709/s23/41/q1]

Two particles P and Q , of masses m kg and 0.3 kg respectively, are at rest on a smooth horizontal plane. P is projected at a speed of 5 m s^{-1} directly towards Q . After P and Q collide, P moves with a speed of 2 m s^{-1} in the same direction as it was originally moving.

(a) Find, in terms of m , the speed of Q after the collision. [2]

After this collision, Q moves directly towards a third particle R , of mass 0.6 kg, which is at rest on the plane. Q is brought to rest in the collision with R , and R begins to move with a speed of 1.5 m s^{-1} .

(b) Find the value of m . [2]

19. [9709/s23/42/q2]

Two particles A and B , of masses 3.2 kg and 2.4 kg respectively, lie on a smooth horizontal table. A moves towards B with a speed of $v\text{ m s}^{-1}$ and collides with B , which is moving towards A with a speed of 6 m s^{-1} . In the collision the two particles come to rest.

- (a) Find the value of v . [2]
- (b) Find the loss of kinetic energy of the system due to the collision. [2]

20. [9709/s23/43/q1]

Two particles P and Q , of masses 0.1 kg and 0.4 kg respectively, are free to move on a smooth horizontal plane. Particle P is projected with speed 4 m s^{-1} towards Q which is stationary. After P and Q collide, the speeds of P and Q are equal.

Find the two possible values of the speed of P after the collision.

[3]

21. [9709/w23/41/q4]

Two particles P and Q , of masses 6 kg and 2 kg respectively, lie at rest 12.5 m apart on a rough horizontal plane. The coefficient of friction between each particle and the plane is 0.4. Particle P is projected towards Q with speed 20 m s^{-1} .

(a) Show that the speed of P immediately before the collision with Q is $10\sqrt{3} \text{ m s}^{-1}$. [3]

In the collision P and Q coalesce to form particle R .

(b) Find the loss of kinetic energy due to the collision. [4]

The coefficient of friction between R and the plane is 0.4.

(c) Find the distance travelled by particle R before coming to rest. [2]

22. [9709/w23/42/q5]

A particle A of mass 0.5 kg is projected vertically upwards from horizontal ground with speed 25 m s^{-1} .

- (a) Find the speed of A when it reaches a height of 20 m above the ground. [2]

When A reaches a height of 20 m , it collides with a particle B of mass 0.3 kg which is moving downwards in the same vertical line as A with speed 32.5 m s^{-1} . In the collision between the two particles, B is brought to instantaneous rest.

- (b) Show that the velocity of A immediately after the collision is 4.5 m s^{-1} downwards. [2]

- (c) Find the time interval between A and B reaching the ground. You should assume that A does not bounce when it reaches the ground. [4]

23. [9709/w23/43/q2]

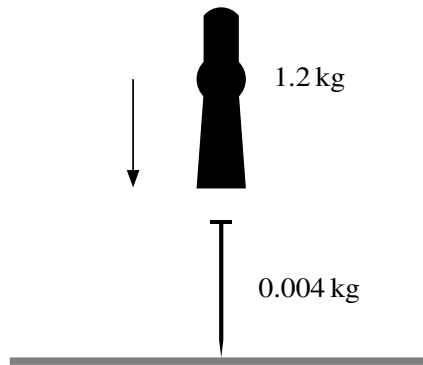

A machine for driving a nail into a block of wood causes a hammerhead to drop vertically onto the top of a nail. The mass of the hammerhead is 1.2 kg and the mass of the nail is 0.004 kg (see diagram). The hammerhead hits the nail with speed $v \text{ m s}^{-1}$ and remains in contact with the nail after the impact. The combined hammerhead and nail move immediately after the impact with speed 40 m s^{-1} .

(a) Calculate v , giving your answer as an exact fraction. [2]

(b) The nail is driven 4 cm into the wood.

Find the constant force resisting the motion. [3]

24. [9709/m22/42/q7]

A bead, A , of mass 0.1 kg is threaded on a long straight rigid wire which is inclined at $\sin^{-1}\left(\frac{7}{25}\right)$ to the horizontal. A is released from rest and moves down the wire. The coefficient of friction between A and the wire is μ . When A has travelled 0.45 m down the wire, its speed is 0.6 m s^{-1} .

(a) Show that $\mu = 0.25$. [6]

Another bead, B , of mass 0.5 kg is also threaded on the wire. At the point where A has travelled 0.45 m down the wire, it hits B which is instantaneously at rest on the wire. A is brought to instantaneous rest in the collision. The coefficient of friction between B and the wire is 0.275 .

(b) Find the time from when the collision occurs until A collides with B again. [6]

25. [9709/s22/41/q7]

Two particles A and B , of masses 0.4 kg and 0.2 kg respectively, are moving down the same line of greatest slope of a smooth plane. The plane is inclined at 30° to the horizontal, and A is higher up the plane than B . When the particles collide, the speeds of A and B are 3 m s^{-1} and 2 m s^{-1} respectively. In the collision between the particles, the speed of A is reduced to 2.5 m s^{-1} .

- (a) Find the speed of B immediately after the collision. [2]

After the collision, when B has moved 1.6 m down the plane from the point of collision, it hits a barrier and returns back up the same line of greatest slope. B hits the barrier 0.4 s after the collision, and when it hits the barrier, its speed is reduced by 90% . The two particles collide again 0.44 s after their previous collision, and they then coalesce on impact.

- (b) Show that the speed of B immediately after it hits the barrier is 0.5 m s^{-1} . Hence find the speed of the combined particle immediately after the second collision between A and B . [7]

26. [9709/s22/42/q1]

Small smooth spheres A and B , of equal radii and of masses 5 kg and 3 kg respectively, lie on a smooth horizontal plane. Initially B is at rest and A is moving towards B with speed 8.5 m s^{-1} . The spheres collide and after the collision A continues to move in the same direction but with a quarter of the speed of B .

- (a) Find the speed of B after the collision. [3]
- (b) Find the loss of kinetic energy of the system due to the collision. [2]

27. [9709/s22/43/q1]

Two particles P and Q , of masses 0.3 kg and 0.2 kg respectively, are at rest on a smooth horizontal plane. P is projected at a speed of 4 m s^{-1} directly towards Q . After P and Q collide, Q begins to move with a speed of 3 m s^{-1} .

(a) Find the speed of P after the collision. [2]

After the collision, Q moves directly towards a third particle R , of mass $m\text{ kg}$, which is at rest on the plane. The two particles Q and R coalesce on impact and move with a speed of 2 m s^{-1} .

(b) Find m . [2]

28. [9709/w22/41/q2]

Small smooth spheres A and B , of equal radii and of masses 6 kg and 2 kg respectively, lie on a smooth horizontal plane. Initially A is moving towards B with speed 5 m s^{-1} and B is moving towards A with speed 3 m s^{-1} . After the spheres collide, both A and B move in the same direction and the difference in the speeds of the spheres is 2 m s^{-1} .

Find the loss of kinetic energy of the system due to the collision.

[5]

29. [9709/w22/42/q6]

Three particles A , B and C of masses 0.3 kg, 0.4 kg and m kg respectively lie at rest in a straight line on a smooth horizontal plane. The distance between B and C is 2.1 m. A is projected directly towards B with speed 2 m s^{-1} . After A collides with B the speed of A is reduced to 0.6 m s^{-1} , still moving in the same direction.

(a) Show that the speed of B after the collision is 1.05 m s^{-1} . [2]

After the collision between A and B , B moves directly towards C . Particle B now collides with C . After this collision, the two particles coalesce and have a combined speed of 0.5 m s^{-1} .

(b) Find m . [2]

(c) Find the time that it takes, from the instant when B and C collide, until A collides with the combined particle. [5]

30. [9709/w22/43/q7]

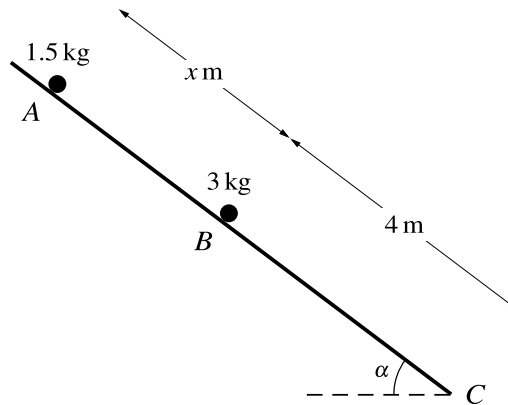

Particles of masses 1.5 kg and 3 kg lie on a plane which is inclined at an angle of α to the horizontal, where $\tan \alpha = \frac{3}{4}$. The section of the plane from A to B is smooth and the section of the plane from B to C is rough. The 1.5 kg particle is held at rest at A and the 3 kg particle is in limiting equilibrium at B . The distance AB is x m and the distance BC is 4 m (see diagram).

(a) Show that the coefficient of friction between the particle at B and the plane is 0.75. [3]

The 1.5 kg particle is released from rest. In the subsequent motion the two particles collide and coalesce. The time taken for the combined particle to travel from B to C is 2 s. The coefficient of friction between the combined particle and the plane is still 0.75.

(b) Find x . [6]

(c) Find the total loss of energy of the particles from the time the 1.5 kg particle is released until the combined particle reaches C . [3]

31. [9709/m21/42/q1]

Two particles P and Q of masses 0.2 kg and 0.3 kg respectively are free to move in a horizontal straight line on a smooth horizontal plane. P is projected towards Q with speed 0.5 m s^{-1} . At the same instant Q is projected towards P with speed 1 m s^{-1} . Q comes to rest in the resulting collision.

Find the speed of P after the collision.

[3]

32. [9709/s21/41/q3]

Three particles P , Q and R , of masses 0.1 kg, 0.2 kg and 0.5 kg respectively, are at rest in a straight line on a smooth horizontal plane. Particle P is projected towards Q at a speed of 5 m s^{-1} . After P and Q collide, P rebounds with speed 1 m s^{-1} .

(a) Find the speed of Q immediately after the collision with P . [3]

Q now collides with R . Immediately after the collision with Q , R begins to move with speed $V \text{ m s}^{-1}$.

(b) Given that there is no subsequent collision between P and Q , find the greatest possible value of V . [3]

33. [9709/s21/42/q6]

A particle A is projected vertically upwards from level ground with an initial speed of 30 m s^{-1} . At the same instant a particle B is released from rest 15 m vertically above A . The mass of one of the particles is twice the mass of the other particle. During the subsequent motion A and B collide and coalesce to form particle C .

Find the difference between the two possible times at which C hits the ground. [8]

34. [9709/s21/43/q1]

Particles P of mass 0.4 kg and Q of mass 0.5 kg are free to move on a smooth horizontal plane. P and Q are moving directly towards each other with speeds 2.5 m s^{-1} and 1.5 m s^{-1} respectively. After P and Q collide, the speed of Q is twice the speed of P .

Find the two possible values of the speed of P after the collision.

[4]

35. [9709/w21/41/q2]

Two small smooth spheres A and B , of equal radii and of masses km kg and m kg respectively, where $k > 1$, are free to move on a smooth horizontal plane. A is moving towards B with speed 6 m s^{-1} and B is moving towards A with speed 2 m s^{-1} . After the collision A and B coalesce and move with speed 4 m s^{-1} .

(a) Find k . [3]

(b) Find, in terms of m , the loss of kinetic energy due to the collision. [2]

36. [9709/w21/42/q7]

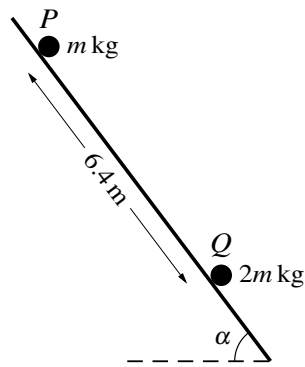

Particles P and Q have masses m kg and $2m$ kg respectively. The particles are initially held at rest 6.4 m apart on the same line of greatest slope of a rough plane inclined at an angle α to the horizontal, where $\sin \alpha = 0.8$ (see diagram). Particle P is released from rest and slides down the line of greatest slope. Simultaneously, particle Q is projected up the same line of greatest slope at a speed of 10 m s^{-1} . The coefficient of friction between each particle and the plane is 0.6.

- (a) Show that the acceleration of Q up the plane is -11.6 m s^{-2} . [4]
- (b) Find the time for which the particles are in motion before they collide. [5]
- (c) The particles coalesce on impact.

Find the speed of the combined particle immediately after the impact. [4]

37. [9709/w21/43/q1]

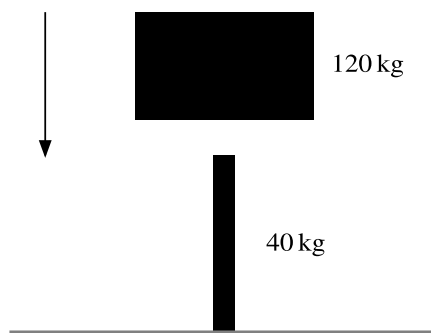

A metal post is driven vertically into the ground by dropping a heavy object onto it from above. The mass of the object is 120 kg and the mass of the post is 40 kg (see diagram). The object hits the post with speed 8 m s^{-1} and remains in contact with it after the impact.

(a) Calculate the speed with which the combined post and object moves immediately after the impact. [2]

(b) There is a constant force resisting the motion of magnitude 4800 N.

Calculate the distance the post is driven into the ground. [3]

38. [9709/m20/42/q6]

On a straight horizontal test track, driverless vehicles (with no passengers) are being tested. A car of mass 1600 kg is towing a trailer of mass 700 kg along the track. The brakes are applied, resulting in a deceleration of 12 m s^{-2} . The braking force acts on the car only. In addition to the braking force there are constant resistance forces of 600 N on the car and of 200 N on the trailer.

(a) Find the magnitude of the force in the tow-bar. [2]

(b) Find the braking force. [2]

(c) At the instant when the brakes are applied, the car has speed 22 m s^{-1} . At this instant the car is 17.5 m away from a stationary van, which is directly in front of the car.

Show that the car hits the van at a speed of 8 m s^{-1} . [2]

(d) After the collision, the van starts to move with speed 5 m s^{-1} and the car and trailer continue moving in the same direction with speed 2 m s^{-1} .

Find the mass of the van. [3]

39. [9709/s20/41/q7]

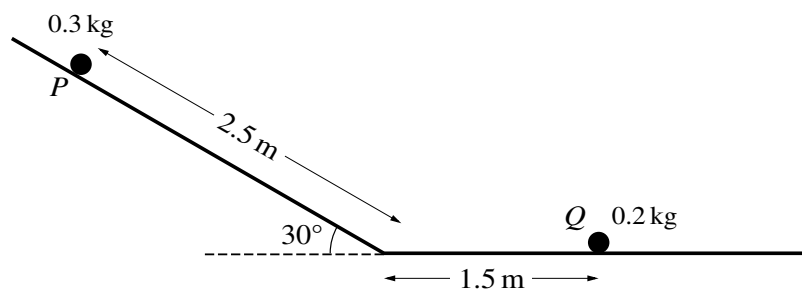

A particle P of mass 0.3 kg, lying on a smooth plane inclined at 30° to the horizontal, is released from rest. P slides down the plane for a distance of 2.5 m and then reaches a horizontal plane. There is no change in speed when P reaches the horizontal plane. A particle Q of mass 0.2 kg lies at rest on the horizontal plane 1.5 m from the end of the inclined plane (see diagram). P collides directly with Q .

- (a) It is given that the horizontal plane is smooth and that, after the collision, P continues moving in the same direction, with speed 2 m s^{-1} .

Find the speed of Q after the collision. [5]

- (b) It is given instead that the horizontal plane is rough and that when P and Q collide, they coalesce and move with speed 1.2 m s^{-1} .

Find the coefficient of friction between P and the horizontal plane. [5]

40. [9709/s20/42/q4]

Small smooth spheres A and B , of equal radii and of masses 4 kg and 2 kg respectively, lie on a smooth horizontal plane. Initially B is at rest and A is moving towards B with speed 10 m s^{-1} . After the spheres collide A continues to move in the same direction but with half the speed of B .

(a) Find the speed of B after the collision. [2]

A third small smooth sphere C , of mass 1 kg and with the same radius as A and B , is at rest on the plane. B now collides directly with C . After this collision B continues to move in the same direction but with one third the speed of C .

(b) Show that there is another collision between A and B . [3]

(c) A and B coalesce during this collision.

Find the total loss of kinetic energy in the system due to the three collisions. [5]

41. [9709/s20/43/q1]

Particles P of mass m kg and Q of mass 0.2 kg are free to move on a smooth horizontal plane. P is projected at a speed of 2 m s^{-1} towards Q which is stationary. After the collision P and Q move in opposite directions with speeds of 0.5 m s^{-1} and 1 m s^{-1} respectively.

Find m .

[3]

42. [9709/w20/41/q1]

A particle B of mass 5 kg is at rest on a smooth horizontal table. A particle A of mass 2.5 kg moves on the table with a speed of 6 m s^{-1} and collides directly with B . In the collision the two particles coalesce.

(a) Find the speed of the combined particle after the collision. [2]

(b) Find the loss of kinetic energy of the system due to the collision. [3]

43. [9709/w20/42/q1]

Two particles P and Q , of masses 0.2 kg and 0.5 kg respectively, are at rest on a smooth horizontal plane. P is projected towards Q with speed 2 m s^{-1} .

(a) Write down the momentum of P . [1]

(b) After the collision P continues to move in the same direction with speed 0.3 m s^{-1} .

Find the speed of Q after the collision. [2]

44. [9709/w20/43/q4]

Two small smooth spheres A and B , of equal radii and of masses 4 kg and $m \text{ kg}$ respectively, lie on a smooth horizontal plane. Initially, sphere B is at rest and A is moving towards B with speed 6 m s^{-1} . After the collision A moves with speed 1.5 m s^{-1} and B moves with speed 3 m s^{-1} .

Find the two possible values of the loss of kinetic energy due to the collision.

[6]

Formula Sheet MF19



**Cambridge Assessment
International Education**

List MF19

List of formulae and statistical tables

**Cambridge International AS & A Level
Mathematics (9709) and Further Mathematics (9231)**

For use from 2020 in all papers for the above syllabuses.

CST319



* 2 5 0 8 7 0 9 7 0 1 *

Edited by Thoridal

PURE MATHEMATICS

Mensuration

$$\text{Volume of sphere} = \frac{4}{3}\pi r^3$$

$$\text{Surface area of sphere} = 4\pi r^2$$

$$\text{Volume of cone or pyramid} = \frac{1}{3} \times \text{base area} \times \text{height}$$

$$\text{Area of curved surface of cone} = \pi r \times \text{slant height}$$

$$\text{Arc length of circle} = r\theta \quad (\theta \text{ in radians})$$

$$\text{Area of sector of circle} = \frac{1}{2}r^2\theta \quad (\theta \text{ in radians})$$

Algebra

For the quadratic equation $ax^2 + bx + c = 0$:

$$x = \frac{-b \pm \sqrt{b^2 - 4ac}}{2a}$$

For an arithmetic series:

$$u_n = a + (n-1)d, \quad S_n = \frac{1}{2}n(a+l) = \frac{1}{2}n\{2a + (n-1)d\}$$

For a geometric series:

$$u_n = ar^{n-1}, \quad S_n = \frac{a(1-r^n)}{1-r} \quad (r \neq 1), \quad S_\infty = \frac{a}{1-r} \quad (|r| < 1)$$

Binomial series:

$$(a+b)^n = a^n + \binom{n}{1} a^{n-1}b + \binom{n}{2} a^{n-2}b^2 + \binom{n}{3} a^{n-3}b^3 + \dots + b^n, \text{ where } n \text{ is a positive integer}$$

$$\text{and } \binom{n}{r} = \frac{n!}{r!(n-r)!}$$

$$(1+x)^n = 1 + nx + \frac{n(n-1)}{2!}x^2 + \frac{n(n-1)(n-2)}{3!}x^3 + \dots, \text{ where } n \text{ is rational and } |x| < 1$$

Trigonometry

$$\tan \theta \equiv \frac{\sin \theta}{\cos \theta}$$

$$\cos^2 \theta + \sin^2 \theta \equiv 1,$$

$$1 + \tan^2 \theta \equiv \sec^2 \theta,$$

$$\cot^2 \theta + 1 \equiv \operatorname{cosec}^2 \theta$$

$$\sin(A \pm B) \equiv \sin A \cos B \pm \cos A \sin B$$

$$\cos(A \pm B) \equiv \cos A \cos B \mp \sin A \sin B$$

$$\tan(A \pm B) \equiv \frac{\tan A \pm \tan B}{1 \mp \tan A \tan B}$$

$$\sin 2A \equiv 2 \sin A \cos A$$

$$\cos 2A \equiv \cos^2 A - \sin^2 A \equiv 2 \cos^2 A - 1 \equiv 1 - 2 \sin^2 A$$

$$\tan 2A \equiv \frac{2 \tan A}{1 - \tan^2 A}$$

Principal values:

$$-\frac{1}{2}\pi \leq \sin^{-1} x \leq \frac{1}{2}\pi,$$

$$0 \leq \cos^{-1} x \leq \pi,$$

$$-\frac{1}{2}\pi < \tan^{-1} x < \frac{1}{2}\pi$$

Differentiation

f(x)	f'(x)
x^n	nx^{n-1}
$\ln x$	$\frac{1}{x}$
e^x	e^x
$\sin x$	$\cos x$
$\cos x$	$-\sin x$
$\tan x$	$\sec^2 x$
$\sec x$	$\sec x \tan x$
$\operatorname{cosec} x$	$-\operatorname{cosec} x \cot x$
$\cot x$	$-\operatorname{cosec}^2 x$
$\tan^{-1} x$	$\frac{1}{1+x^2}$
uv	$v \frac{du}{dx} + u \frac{dv}{dx}$
$\frac{u}{v}$	$\frac{v \frac{du}{dx} - u \frac{dv}{dx}}{v^2}$

$$\text{If } x = f(t) \text{ and } y = g(t) \text{ then } \frac{dy}{dx} = \frac{dy}{dt} \div \frac{dx}{dt}$$

Integration(Arbitrary constants are omitted; a denotes a positive constant.)

$f(x)$	$\int f(x) dx$	
x^n	$\frac{x^{n+1}}{n+1}$	$(n \neq -1)$
$\frac{1}{x}$	$\ln x $	
e^x	e^x	
$\sin x$	$-\cos x$	
$\cos x$	$\sin x$	
$\sec^2 x$	$\tan x$	
$\frac{1}{x^2 + a^2}$	$\frac{1}{a} \tan^{-1}\left(\frac{x}{a}\right)$	
$\frac{1}{x^2 - a^2}$	$\frac{1}{2a} \ln \left \frac{x-a}{x+a} \right $	$(x > a)$
$\frac{1}{a^2 - x^2}$	$\frac{1}{2a} \ln \left \frac{a+x}{a-x} \right $	$(x < a)$

$$\int u \frac{dv}{dx} dx = uv - \int v \frac{du}{dx} dx$$

$$\int \frac{f'(x)}{f(x)} dx = \ln|f(x)|$$

*Vectors*If $\mathbf{a} = a_1\mathbf{i} + a_2\mathbf{j} + a_3\mathbf{k}$ and $\mathbf{b} = b_1\mathbf{i} + b_2\mathbf{j} + b_3\mathbf{k}$ then

$$\mathbf{a} \cdot \mathbf{b} = a_1b_1 + a_2b_2 + a_3b_3 = |\mathbf{a}| |\mathbf{b}| \cos \theta$$

FURTHER PURE MATHEMATICS

Algebra

Summations:

$$\sum_{r=1}^n r = \frac{1}{2}n(n+1), \quad \sum_{r=1}^n r^2 = \frac{1}{6}n(n+1)(2n+1), \quad \sum_{r=1}^n r^3 = \frac{1}{4}n^2(n+1)^2$$

Maclaurin's series:

$$f(x) = f(0) + x f'(0) + \frac{x^2}{2!} f''(0) + \dots + \frac{x^r}{r!} f^{(r)}(0) + \dots$$

$$e^x = \exp(x) = 1 + x + \frac{x^2}{2!} + \dots + \frac{x^r}{r!} + \dots \quad (\text{all } x)$$

$$\ln(1+x) = x - \frac{x^2}{2} + \frac{x^3}{3} - \dots + (-1)^{r+1} \frac{x^r}{r} + \dots \quad (-1 < x \leq 1)$$

$$\sin x = x - \frac{x^3}{3!} + \frac{x^5}{5!} - \dots + (-1)^r \frac{x^{2r+1}}{(2r+1)!} + \dots \quad (\text{all } x)$$

$$\cos x = 1 - \frac{x^2}{2!} + \frac{x^4}{4!} - \dots + (-1)^r \frac{x^{2r}}{(2r)!} + \dots \quad (\text{all } x)$$

$$\tan^{-1} x = x - \frac{x^3}{3} + \frac{x^5}{5} - \dots + (-1)^r \frac{x^{2r+1}}{2r+1} + \dots \quad (-1 \leq x \leq 1)$$

$$\sinh x = x + \frac{x^3}{3!} + \frac{x^5}{5!} + \dots + \frac{x^{2r+1}}{(2r+1)!} + \dots \quad (\text{all } x)$$

$$\cosh x = 1 + \frac{x^2}{2!} + \frac{x^4}{4!} + \dots + \frac{x^{2r}}{(2r)!} + \dots \quad (\text{all } x)$$

$$\tanh^{-1} x = x + \frac{x^3}{3} + \frac{x^5}{5} + \dots + \frac{x^{2r+1}}{2r+1} + \dots \quad (-1 < x < 1)$$

Trigonometry

If $t = \tan \frac{1}{2}x$ then:

$$\sin x = \frac{2t}{1+t^2} \quad \text{and} \quad \cos x = \frac{1-t^2}{1+t^2}$$

Hyperbolic functions

$$\cosh^2 x - \sinh^2 x \equiv 1, \quad \sinh 2x \equiv 2 \sinh x \cosh x, \quad \cosh 2x \equiv \cosh^2 x + \sinh^2 x$$

$$\sinh^{-1} x = \ln(x + \sqrt{x^2 + 1})$$

$$\cosh^{-1} x = \ln(x + \sqrt{x^2 - 1}) \quad (x \geq 1)$$

$$\tanh^{-1} x = \frac{1}{2} \ln \left(\frac{1+x}{1-x} \right) \quad (|x| < 1)$$

Differentiation

$f(x)$	$f'(x)$
$\sin^{-1} x$	$\frac{1}{\sqrt{1-x^2}}$
$\cos^{-1} x$	$-\frac{1}{\sqrt{1-x^2}}$
$\sinh x$	$\cosh x$
$\cosh x$	$\sinh x$
$\tanh x$	$\operatorname{sech}^2 x$
$\sinh^{-1} x$	$\frac{1}{\sqrt{1+x^2}}$
$\cosh^{-1} x$	$\frac{1}{\sqrt{x^2-1}}$
$\tanh^{-1} x$	$\frac{1}{1-x^2}$

Integration

(Arbitrary constants are omitted; a denotes a positive constant.)

$f(x)$	$\int f(x) dx$	
$\sec x$	$\ln \sec x + \tan x = \ln \tan(\frac{1}{2}x + \frac{1}{4}\pi) $	$(x < \frac{1}{2}\pi)$
$\operatorname{cosec} x$	$-\ln \operatorname{cosec} x + \cot x = \ln \tan(\frac{1}{2}x) $	$(0 < x < \pi)$
$\sinh x$	$\cosh x$	
$\cosh x$	$\sinh x$	
$\operatorname{sech}^2 x$	$\tanh x$	
$\frac{1}{\sqrt{a^2-x^2}}$	$\sin^{-1}\left(\frac{x}{a}\right)$	$(x < a)$
$\frac{1}{\sqrt{x^2-a^2}}$	$\cosh^{-1}\left(\frac{x}{a}\right)$	$(x > a)$
$\frac{1}{\sqrt{a^2+x^2}}$	$\sinh^{-1}\left(\frac{x}{a}\right)$	

MECHANICS*Uniformly accelerated motion*

$$v = u + at, \quad s = \frac{1}{2}(u + v)t, \quad s = ut + \frac{1}{2}at^2, \quad v^2 = u^2 + 2as$$

FURTHER MECHANICS*Motion of a projectile*

Equation of trajectory is:

$$y = x \tan \theta - \frac{gx^2}{2V^2 \cos^2 \theta}$$

Elastic strings and springs

$$T = \frac{\lambda x}{l}, \quad E = \frac{\lambda x^2}{2l}$$

Motion in a circle

For uniform circular motion, the acceleration is directed towards the centre and has magnitude

$$\omega^2 r \quad \text{or} \quad \frac{v^2}{r}$$

*Centres of mass of uniform bodies*Triangular lamina: $\frac{2}{3}$ along median from vertexSolid hemisphere of radius r : $\frac{3}{8}r$ from centreHemispherical shell of radius r : $\frac{1}{2}r$ from centreCircular arc of radius r and angle 2α : $\frac{r \sin \alpha}{\alpha}$ from centreCircular sector of radius r and angle 2α : $\frac{2r \sin \alpha}{3\alpha}$ from centreSolid cone or pyramid of height h : $\frac{3}{4}h$ from vertex

PROBABILITY & STATISTICS

Summary statistics

For ungrouped data:

$$\bar{x} = \frac{\Sigma x}{n}, \quad \text{standard deviation} = \sqrt{\frac{\Sigma(x - \bar{x})^2}{n}} = \sqrt{\frac{\Sigma x^2}{n} - \bar{x}^2}$$

For grouped data:

$$\bar{x} = \frac{\Sigma xf}{\Sigma f}, \quad \text{standard deviation} = \sqrt{\frac{\Sigma(x - \bar{x})^2 f}{\Sigma f}} = \sqrt{\frac{\Sigma x^2 f}{\Sigma f} - \bar{x}^2}$$

Discrete random variables

$$E(X) = \Sigma xp, \quad \text{Var}(X) = \Sigma x^2 p - \{E(X)\}^2$$

For the binomial distribution $B(n, p)$:

$$p_r = \binom{n}{r} p^r (1-p)^{n-r}, \quad \mu = np, \quad \sigma^2 = np(1-p)$$

For the geometric distribution $\text{Geo}(p)$:

$$p_r = p(1-p)^{r-1}, \quad \mu = \frac{1}{p}$$

For the Poisson distribution $\text{Po}(\lambda)$

$$p_r = e^{-\lambda} \frac{\lambda^r}{r!}, \quad \mu = \lambda, \quad \sigma^2 = \lambda$$

Continuous random variables

$$E(X) = \int x f(x) dx, \quad \text{Var}(X) = \int x^2 f(x) dx - \{E(X)\}^2$$

Sampling and testing

Unbiased estimators:

$$\bar{x} = \frac{\Sigma x}{n}, \quad s^2 = \frac{\Sigma(x - \bar{x})^2}{n-1} = \frac{1}{n-1} \left(\Sigma x^2 - \frac{(\Sigma x)^2}{n} \right)$$

Central Limit Theorem:

$$\bar{X} \sim N\left(\mu, \frac{\sigma^2}{n}\right)$$

Approximate distribution of sample proportion:

$$N\left(p, \frac{p(1-p)}{n}\right)$$

FURTHER PROBABILITY & STATISTICS*Sampling and testing*

Two-sample estimate of a common variance:

$$s^2 = \frac{\Sigma(x_1 - \bar{x}_1)^2 + \Sigma(x_2 - \bar{x}_2)^2}{n_1 + n_2 - 2}$$

Probability generating functions

$$G_X(t) = E(t^X), \quad E(X) = G'_X(1), \quad \text{Var}(X) = G''_X(1) + G'_X(1) - \{G'_X(1)\}^2$$

THE NORMAL DISTRIBUTION FUNCTION

If Z has a normal distribution with mean 0 and variance 1, then, for each value of z , the table gives the value of $\Phi(z)$, where

$$\Phi(z) = P(Z \leq z).$$

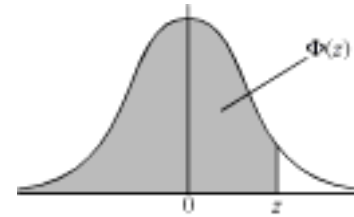

For negative values of z , use $\Phi(-z) = 1 - \Phi(z)$.

z											ADD								
	0	1	2	3	4	5	6	7	8	9	1	2	3	4	5	6	7	8	9
0.0	0.5000	0.5040	0.5080	0.5120	0.5160	0.5199	0.5239	0.5279	0.5319	0.5359	4	8	12	16	20	24	28	32	36
0.1	0.5398	0.5438	0.5478	0.5517	0.5557	0.5596	0.5636	0.5675	0.5714	0.5753	4	8	12	16	20	24	28	32	36
0.2	0.5793	0.5832	0.5871	0.5910	0.5948	0.5987	0.6026	0.6064	0.6103	0.6141	4	8	12	15	19	23	27	31	35
0.3	0.6179	0.6217	0.6255	0.6293	0.6331	0.6368	0.6406	0.6443	0.6480	0.6517	4	7	11	15	19	22	26	30	34
0.4	0.6554	0.6591	0.6628	0.6664	0.6700	0.6736	0.6772	0.6808	0.6844	0.6879	4	7	11	14	18	22	25	29	32
0.5	0.6915	0.6950	0.6985	0.7019	0.7054	0.7088	0.7123	0.7157	0.7190	0.7224	3	7	10	14	17	20	24	27	31
0.6	0.7257	0.7291	0.7324	0.7357	0.7389	0.7422	0.7454	0.7486	0.7517	0.7549	3	7	10	13	16	19	23	26	29
0.7	0.7580	0.7611	0.7642	0.7673	0.7704	0.7734	0.7764	0.7794	0.7823	0.7852	3	6	9	12	15	18	21	24	27
0.8	0.7881	0.7910	0.7939	0.7967	0.7995	0.8023	0.8051	0.8078	0.8106	0.8133	3	5	8	11	14	16	19	22	25
0.9	0.8159	0.8186	0.8212	0.8238	0.8264	0.8289	0.8315	0.8340	0.8365	0.8389	3	5	8	10	13	15	18	20	23
1.0	0.8413	0.8438	0.8461	0.8485	0.8508	0.8531	0.8554	0.8577	0.8599	0.8621	2	5	7	9	12	14	16	19	21
1.1	0.8643	0.8665	0.8686	0.8708	0.8729	0.8749	0.8770	0.8790	0.8810	0.8830	2	4	6	8	10	12	14	16	18
1.2	0.8849	0.8869	0.8888	0.8907	0.8925	0.8944	0.8962	0.8980	0.8997	0.9015	2	4	6	7	9	11	13	15	17
1.3	0.9032	0.9049	0.9066	0.9082	0.9099	0.9115	0.9131	0.9147	0.9162	0.9177	2	3	5	6	8	10	11	13	14
1.4	0.9192	0.9207	0.9222	0.9236	0.9251	0.9265	0.9279	0.9292	0.9306	0.9319	1	3	4	6	7	8	10	11	13
1.5	0.9332	0.9345	0.9357	0.9370	0.9382	0.9394	0.9406	0.9418	0.9429	0.9441	1	2	4	5	6	7	8	10	11
1.6	0.9452	0.9463	0.9474	0.9484	0.9495	0.9505	0.9515	0.9525	0.9535	0.9545	1	2	3	4	5	6	7	8	9
1.7	0.9554	0.9564	0.9573	0.9582	0.9591	0.9599	0.9608	0.9616	0.9625	0.9633	1	2	3	4	4	5	6	7	8
1.8	0.9641	0.9649	0.9656	0.9664	0.9671	0.9678	0.9686	0.9693	0.9699	0.9706	1	1	2	3	4	4	5	6	6
1.9	0.9713	0.9719	0.9726	0.9732	0.9738	0.9744	0.9750	0.9756	0.9761	0.9767	1	1	2	2	3	4	4	5	5
2.0	0.9772	0.9778	0.9783	0.9788	0.9793	0.9798	0.9803	0.9808	0.9812	0.9817	0	1	1	2	2	3	3	4	4
2.1	0.9821	0.9826	0.9830	0.9834	0.9838	0.9842	0.9846	0.9850	0.9854	0.9857	0	1	1	2	2	2	3	3	4
2.2	0.9861	0.9864	0.9868	0.9871	0.9875	0.9878	0.9881	0.9884	0.9887	0.9890	0	1	1	1	2	2	2	3	3
2.3	0.9893	0.9896	0.9898	0.9901	0.9904	0.9906	0.9909	0.9911	0.9913	0.9916	0	1	1	1	1	2	2	2	2
2.4	0.9918	0.9920	0.9922	0.9925	0.9927	0.9929	0.9931	0.9932	0.9934	0.9936	0	0	1	1	1	1	1	2	2
2.5	0.9938	0.9940	0.9941	0.9943	0.9945	0.9946	0.9948	0.9949	0.9951	0.9952	0	0	0	1	1	1	1	1	1
2.6	0.9953	0.9955	0.9956	0.9957	0.9959	0.9960	0.9961	0.9962	0.9963	0.9964	0	0	0	0	1	1	1	1	1
2.7	0.9965	0.9966	0.9967	0.9968	0.9969	0.9970	0.9971	0.9972	0.9973	0.9974	0	0	0	0	0	1	1	1	1
2.8	0.9974	0.9975	0.9976	0.9977	0.9977	0.9978	0.9979	0.9979	0.9980	0.9981	0	0	0	0	0	0	0	1	1
2.9	0.9981	0.9982	0.9982	0.9983	0.9984	0.9984	0.9985	0.9985	0.9986	0.9986	0	0	0	0	0	0	0	0	0

Critical values for the normal distribution

If Z has a normal distribution with mean 0 and variance 1, then, for each value of p , the table gives the value of z such that

$$P(Z \leq z) = p.$$

p	0.75	0.90	0.95	0.975	0.99	0.995	0.9975	0.999	0.9995
z	0.674	1.282	1.645	1.960	2.326	2.576	2.807	3.090	3.291

CRITICAL VALUES FOR THE t -DISTRIBUTION

If T has a t -distribution with ν degrees of freedom, then, for each pair of values of p and ν , the table gives the value of t such that:

$$P(T \leq t) = p.$$



p	0.75	0.90	0.95	0.975	0.99	0.995	0.9975	0.999	0.9995
$\nu = 1$	1.000	3.078	6.314	12.71	31.82	63.66	127.3	318.3	636.6
2	0.816	1.886	2.920	4.303	6.965	9.925	14.09	22.33	31.60
3	0.765	1.638	2.353	3.182	4.541	5.841	7.453	10.21	12.92
4	0.741	1.533	2.132	2.776	3.747	4.604	5.598	7.173	8.610
5	0.727	1.476	2.015	2.571	3.365	4.032	4.773	5.894	6.869
6	0.718	1.440	1.943	2.447	3.143	3.707	4.317	5.208	5.959
7	0.711	1.415	1.895	2.365	2.998	3.499	4.029	4.785	5.408
8	0.706	1.397	1.860	2.306	2.896	3.355	3.833	4.501	5.041
9	0.703	1.383	1.833	2.262	2.821	3.250	3.690	4.297	4.781
10	0.700	1.372	1.812	2.228	2.764	3.169	3.581	4.144	4.587
11	0.697	1.363	1.796	2.201	2.718	3.106	3.497	4.025	4.437
12	0.695	1.356	1.782	2.179	2.681	3.055	3.428	3.930	4.318
13	0.694	1.350	1.771	2.160	2.650	3.012	3.372	3.852	4.221
14	0.692	1.345	1.761	2.145	2.624	2.977	3.326	3.787	4.140
15	0.691	1.341	1.753	2.131	2.602	2.947	3.286	3.733	4.073
16	0.690	1.337	1.746	2.120	2.583	2.921	3.252	3.686	4.015
17	0.689	1.333	1.740	2.110	2.567	2.898	3.222	3.646	3.965
18	0.688	1.330	1.734	2.101	2.552	2.878	3.197	3.610	3.922
19	0.688	1.328	1.729	2.093	2.539	2.861	3.174	3.579	3.883
20	0.687	1.325	1.725	2.086	2.528	2.845	3.153	3.552	3.850
21	0.686	1.323	1.721	2.080	2.518	2.831	3.135	3.527	3.819
22	0.686	1.321	1.717	2.074	2.508	2.819	3.119	3.505	3.792
23	0.685	1.319	1.714	2.069	2.500	2.807	3.104	3.485	3.768
24	0.685	1.318	1.711	2.064	2.492	2.797	3.091	3.467	3.745
25	0.684	1.316	1.708	2.060	2.485	2.787	3.078	3.450	3.725
26	0.684	1.315	1.706	2.056	2.479	2.779	3.067	3.435	3.707
27	0.684	1.314	1.703	2.052	2.473	2.771	3.057	3.421	3.689
28	0.683	1.313	1.701	2.048	2.467	2.763	3.047	3.408	3.674
29	0.683	1.311	1.699	2.045	2.462	2.756	3.038	3.396	3.660
30	0.683	1.310	1.697	2.042	2.457	2.750	3.030	3.385	3.646
40	0.681	1.303	1.684	2.021	2.423	2.704	2.971	3.307	3.551
60	0.679	1.296	1.671	2.000	2.390	2.660	2.915	3.232	3.460
120	0.677	1.289	1.658	1.980	2.358	2.617	2.860	3.160	3.373
∞	0.674	1.282	1.645	1.960	2.326	2.576	2.807	3.090	3.291

CRITICAL VALUES FOR THE χ^2 -DISTRIBUTION

If X has a χ^2 -distribution with ν degrees of freedom then, for each pair of values of p and ν , the table gives the value of x such that

$$P(X \leq x) = p.$$



p	0.01	0.025	0.05	0.9	0.95	0.975	0.99	0.995	0.999
$\nu=1$	0.0 ³ 1571	0.0 ³ 9821	0.0 ² 3932	2.706	3.841	5.024	6.635	7.879	10.83
2	0.02010	0.05064	0.1026	4.605	5.991	7.378	9.210	10.60	13.82
3	0.1148	0.2158	0.3518	6.251	7.815	9.348	11.34	12.84	16.27
4	0.2971	0.4844	0.7107	7.779	9.488	11.14	13.28	14.86	18.47
5	0.5543	0.8312	1.145	9.236	11.07	12.83	15.09	16.75	20.51
6	0.8721	1.237	1.635	10.64	12.59	14.45	16.81	18.55	22.46
7	1.239	1.690	2.167	12.02	14.07	16.01	18.48	20.28	24.32
8	1.647	2.180	2.733	13.36	15.51	17.53	20.09	21.95	26.12
9	2.088	2.700	3.325	14.68	16.92	19.02	21.67	23.59	27.88
10	2.558	3.247	3.940	15.99	18.31	20.48	23.21	25.19	29.59
11	3.053	3.816	4.575	17.28	19.68	21.92	24.73	26.76	31.26
12	3.571	4.404	5.226	18.55	21.03	23.34	26.22	28.30	32.91
13	4.107	5.009	5.892	19.81	22.36	24.74	27.69	29.82	34.53
14	4.660	5.629	6.571	21.06	23.68	26.12	29.14	31.32	36.12
15	5.229	6.262	7.261	22.31	25.00	27.49	30.58	32.80	37.70
16	5.812	6.908	7.962	23.54	26.30	28.85	32.00	34.27	39.25
17	6.408	7.564	8.672	24.77	27.59	30.19	33.41	35.72	40.79
18	7.015	8.231	9.390	25.99	28.87	31.53	34.81	37.16	42.31
19	7.633	8.907	10.12	27.20	30.14	32.85	36.19	38.58	43.82
20	8.260	9.591	10.85	28.41	31.41	34.17	37.57	40.00	45.31
21	8.897	10.28	11.59	29.62	32.67	35.48	38.93	41.40	46.80
22	9.542	10.98	12.34	30.81	33.92	36.78	40.29	42.80	48.27
23	10.20	11.69	13.09	32.01	35.17	38.08	41.64	44.18	49.73
24	10.86	12.40	13.85	33.20	36.42	39.36	42.98	45.56	51.18
25	11.52	13.12	14.61	34.38	37.65	40.65	44.31	46.93	52.62
30	14.95	16.79	18.49	40.26	43.77	46.98	50.89	53.67	59.70
40	22.16	24.43	26.51	51.81	55.76	59.34	63.69	66.77	73.40
50	29.71	32.36	34.76	63.17	67.50	71.42	76.15	79.49	86.66
60	37.48	40.48	43.19	74.40	79.08	83.30	88.38	91.95	99.61
70	45.44	48.76	51.74	85.53	90.53	95.02	100.4	104.2	112.3
80	53.54	57.15	60.39	96.58	101.9	106.6	112.3	116.3	124.8
90	61.75	65.65	69.13	107.6	113.1	118.1	124.1	128.3	137.2
100	70.06	74.22	77.93	118.5	124.3	129.6	135.8	140.2	149.4

WILCOXON SIGNED-RANK TEST

The sample has size n .

P is the sum of the ranks corresponding to the positive differences.

Q is the sum of the ranks corresponding to the negative differences.

T is the smaller of P and Q .

For each value of n the table gives the **largest** value of T which will lead to rejection of the null hypothesis at the level of significance indicated.

Critical values of T

	Level of significance			
	0.05	0.025	0.01	0.005
One-tailed	0.05	0.025	0.01	0.005
Two-tailed	0.1	0.05	0.02	0.01
$n = 6$	2	0		
7	3	2	0	
8	5	3	1	0
9	8	5	3	1
10	10	8	5	3
11	13	10	7	5
12	17	13	9	7
13	21	17	12	9
14	25	21	15	12
15	30	25	19	15
16	35	29	23	19
17	41	34	27	23
18	47	40	32	27
19	53	46	37	32
20	60	52	43	37

For larger values of n , each of P and Q can be approximated by the normal distribution with mean $\frac{1}{4}n(n+1)$ and variance $\frac{1}{24}n(n+1)(2n+1)$.

WILCOXON RANK-SUM TEST

The two samples have sizes m and n , where $m \leq n$.

R_m is the sum of the ranks of the items in the sample of size m .

W is the smaller of R_m and $m(n + m + 1) - R_m$.

For each pair of values of m and n , the table gives the **largest** value of W which will lead to rejection of the null hypothesis at the level of significance indicated.

Critical values of W

	Level of significance											
	0.05	0.025	0.01	0.05	0.025	0.01	0.05	0.025	0.01	0.05	0.025	0.01
One-tailed	0.05	0.025	0.01	0.05	0.025	0.01	0.05	0.025	0.01	0.05	0.025	0.01
Two-tailed	0.1	0.05	0.02	0.1	0.05	0.02	0.1	0.05	0.02	0.1	0.05	0.02
n	$m = 3$			$m = 4$			$m = 5$			$m = 6$		
3	6	–	–									
4	6	–	–	11	10	–						
5	7	6	–	12	11	10	19	17	16			
6	8	7	–	13	12	11	20	18	17	28	26	24
7	8	7	6	14	13	11	21	20	18	29	27	25
8	9	8	6	15	14	12	23	21	19	31	29	27
9	10	8	7	16	14	13	24	22	20	33	31	28
10	10	9	7	17	15	13	26	23	21	35	32	29

	Level of significance											
	0.05	0.025	0.01	0.05	0.025	0.01	0.05	0.025	0.01	0.05	0.025	0.01
One-tailed	0.05	0.025	0.01	0.05	0.025	0.01	0.05	0.025	0.01	0.05	0.025	0.01
Two-tailed	0.1	0.05	0.02	0.1	0.05	0.02	0.1	0.05	0.02	0.1	0.05	0.02
n	$m = 7$			$m = 8$			$m = 9$			$m = 10$		
7	39	36	34									
8	41	38	35	51	49	45						
9	43	40	37	54	51	47	66	62	59			
10	45	42	39	56	53	49	69	65	61	82	78	74

For larger values of m and n , the normal distribution with mean $\frac{1}{2}m(m + n + 1)$ and variance $\frac{1}{12}mn(m + n + 1)$ should be used as an approximation to the distribution of R_m .

BLANK PAGE

BLANK PAGE

Syllabus 26-27 Mechanics

4 Mechanics (for Paper 4)

Questions set will be mainly numerical, and will aim to test mechanical principles without involving difficult algebra or trigonometry. However, candidates should be familiar in particular with the following trigonometrical results:

$$\sin(90^\circ - \theta) \equiv \cos \theta, \cos(90^\circ - \theta) \equiv \sin \theta, \tan \theta \equiv \frac{\sin \theta}{\cos \theta}, \sin^2 \theta + \cos^2 \theta \equiv 1.$$

Knowledge of algebraic methods from the content for Paper 1: Pure Mathematics 1 is assumed.

This content list refers to the equilibrium or motion of a 'particle'. Examination questions may involve extended bodies in a 'realistic' context, but these extended bodies should be treated as particles, so any force acting on them is modelled as acting at a single point.

Vector notation will not be used in the question papers.

4.1 Forces and equilibrium

Candidates should be able to:

- identify the forces acting in a given situation
- understand the vector nature of force, and find and use components and resultants
- use the principle that, when a particle is in equilibrium, the vector sum of the forces acting is zero, or equivalently, that the sum of the components in any direction is zero
- understand that a contact force between two surfaces can be represented by two components, the normal component and the frictional component
- use the model of a 'smooth' contact, and understand the limitations of this model
- understand the concepts of limiting friction and limiting equilibrium, recall the definition of coefficient of friction, and use the relationship $F = \mu R$ or $F \leq \mu R$, as appropriate
- use Newton's third law.

Notes and examples

e.g. by drawing a force diagram.

Calculations are always required, not approximate solutions by scale drawing.

Solutions by resolving are usually expected, but equivalent methods (e.g. triangle of forces, Lami's Theorem, where suitable) are also acceptable; these other methods are not required knowledge, and will not be referred to in questions.

Terminology such as 'about to slip' may be used to mean 'in limiting equilibrium' in questions.

e.g. the force exerted by a particle on the ground is equal and opposite to the force exerted by the ground on the particle.

4 Mechanics

4.2 Kinematics of motion in a straight line

Candidates should be able to:

- understand the concepts of distance and speed as scalar quantities, and of displacement, velocity and acceleration as vector quantities
- sketch and interpret displacement–time graphs and velocity–time graphs, and in particular appreciate that
 - the area under a velocity–time graph represents displacement,
 - the gradient of a displacement–time graph represents velocity,
 - the gradient of a velocity–time graph represents acceleration
- use differentiation and integration with respect to time to solve simple problems concerning displacement, velocity and acceleration
- use appropriate formulae for motion with constant acceleration in a straight line.

Notes and examples

Restricted to motion in one dimension only.
The term ‘deceleration’ may sometimes be used in the context of decreasing speed.

Calculus required is restricted to techniques from the content for Paper 1: Pure Mathematics 1.

Questions may involve setting up more than one equation, using information about the motion of different particles.

4.3 Momentum

Candidates should be able to:

- use the definition of linear momentum and show understanding of its vector nature
- use conservation of linear momentum to solve problems that may be modelled as the direct impact of two bodies.

Notes and examples

For motion in one dimension only.

Including direct impact of two bodies where the bodies coalesce on impact.

Knowledge of impulse and the coefficient of restitution is not required.

4 Mechanics

4.4 Newton's laws of motion

Candidates should be able to:

- apply Newton's laws of motion to the linear motion of a particle of constant mass moving under the action of constant forces, which may include friction, tension in an inextensible string and thrust in a connecting rod
- use the relationship between mass and weight
- solve simple problems which may be modelled as the motion of a particle moving vertically or on an inclined plane with constant acceleration
- solve simple problems which may be modelled as the motion of connected particles.

Notes and examples

If any other forces resisting motion are to be considered (e.g. air resistance) this will be indicated in the question.

$W = mg$. In this component, questions are mainly numerical, and use of the approximate numerical value $10(\text{m s}^{-2})$ for g is expected.

Including, for example, motion of a particle on a rough plane where the acceleration while moving up the plane is different from the acceleration while moving down the plane.

e.g. particles connected by a light inextensible string passing over a smooth pulley, or a car towing a trailer by means of either a light rope or a light rigid tow-bar.

4.5 Energy, work and power

Candidates should be able to:

- understand the concept of the work done by a force, and calculate the work done by a constant force when its point of application undergoes a displacement not necessarily parallel to the force
- understand the concepts of gravitational potential energy and kinetic energy, and use appropriate formulae
- understand and use the relationship between the change in energy of a system and the work done by the external forces, and use in appropriate cases the principle of conservation of energy
- use the definition of power as the rate at which a force does work, and use the relationship between power, force and velocity for a force acting in the direction of motion
- solve problems involving, for example, the instantaneous acceleration of a car moving on a hill against a resistance.

Notes and examples

$$W = Fd \cos \theta;$$

Use of the scalar product is not required.

Including cases where the motion may not be linear (e.g. a child on a smooth curved 'slide'), where only overall energy changes need to be considered.

Including calculation of (average) power as

$$P = \frac{\text{Work done}}{\text{Time taken}}$$

$$P = Fv.$$